

BHUTANESE ARCHITECTURE GUIDELINES

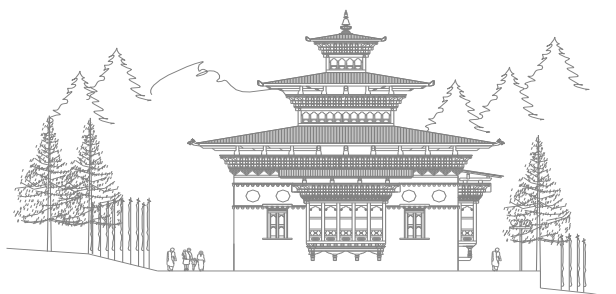

MINISTRY OF WORKS AND HUMAN SETTLEMENT
ROYAL GOVERNMENT OF BHUTAN
YEAR 2014

BHUTANESE ARCHITECTURE GUIDELINES



Ministry of Works and Human Settlement
Royal Government of Bhutan
Year 2014

BHUTANESE ARCHITECTURE GUIDELINES

The Bhutanese Architecture Guidelines
was developed and printed
with funding support from
the Royal Government of Bhutan,
the World Bank and a generous Grant
from the Multi Donor Trust Fund for
Cultural Heritage and Sustainable
Tourism, funded by the Republic of India
and the Republic of Italy.



Published by:

The Ministry of Works and Human Settlement
Royal Government of Bhutan
www.mowhs.gov.bt
PO Box 791, Thimphu, Bhutan
Tel: + 975 - 2 - 327998 / 332218

Year 2014

Copyright:

Copyright of the Guidelines lies with the Ministry of Works and Human Settlement of Bhutan while the copyright of individual photographs and drawings is with their respective owners.

With the sincere objective to ensure gratis distribution of the Guidelines for the conservation of our architectural heritage, every effort has been made to ensure accuracy of information in this document at the time of publication, and to acknowledge photographs, illustrations and information correctly.

All errors or omissions will be corrected or included in subsequent editions of the Guidelines. The Ministry of Works and Human Settlement accepts no responsibility and will not be liable for any errors or omissions contained herein.

FOREWORD

Bhutan's true identity stems from our unique and rich culture and tradition that is entwined with the life style of the people of Bhutan. While most countries are faced with a huge challenge of reviving their age-old culture that is already lost or is on the verge being lost owing largely to modernization, we are fortunate that because of our Kings' visionary leadership we have been able to preserve our rich culture and tradition. One possibly cannot determine where to go if one does not know where he or she comes from. Therefore, Bhutan places immense importance on the culture and how it influences the way of life of our people, which mainly manifest in our rich architecture, arts, dances, festivals, languages, costumes and the sacred sites.

However, rapid urbanization and modernization in construction technologies continue to pose immense pressure on the nation's efforts to preserve and promote our cultural heritage as old low-rise traditional structures are being replaced by new, bigger and high-rise modern structures. There is a palpable risk of losing the essence of our Bhutanese architecture – the scale, details, proportion, materials, etc. We cannot afford to be complacent and hope that all will be well. We need to continue to put in concerted efforts if we are to preserve and promote our unique cultural heritage for posterity.

In supporting Bhutan's pursuit of Gross National Happiness and in particular the pillar of promoting cultural growth and diversity, traditional architecture and methods of construction need to be promoted as the former forms an integral part of our landscape. The previous Traditional Architecture Guidelines has served its purpose but due to changing times we need a much more comprehensive guideline. Towards this end the Ministry of Works and Human Settlement is publishing the Bhutanese Architecture Guidelines 2014 with the objective to support the construction, repair and restoration of traditional structures and construction of modern buildings that are harmonious with traditional architectural design and proportion. The guidelines have been prepared with the generous financial support of the Multi Donor Trust Fund channeled through the World Bank and with the voluntary involvement of many professionals both from the government and the private sector.

It is my sincere hope that the Bhutanese Architecture Guidelines 2014 will go a long way in facilitating all architects, engineers, designers, planners, craftsmen, builders and the people at large to appreciate and contribute in their own capacities towards safe guarding and promoting our beautiful architecture. Therefore, I would like to appeal to all the stakeholders to use the guidelines prudently so that together we can ensure perpetual growth of our cultural heritage for the benefit of ourselves as well as the future generations.



(Dorji Choden)

Minister, Ministry of Works and Human Settlement

ACKNOWLEDGEMENTS

The Guidelines has been compiled by the Ministry of Works and Human Settlement with the help of Yalama Consultancy and contribution of Chapters, drawings and photographs by various local Bhutanese Architects.

Lopon Chang Dorji provided valuable guidance and information on traditional architecture for the Guidelines including terminology and Thobthang.

SECTION ONE:

Coordination and information:

Architects Namgey Retty & Dorji Yangki

COMPILATION OF CHAPTERS:

1. Traditional Architecture of Bhutan – Architect Dorji Yangki
 2. Main Bhutanese Architectural Elements
 - a. Kachen and Zhu
 - b. Jadhong Tazi
 - c. Payab Gochu
 - d. Mago (Doors)
 - e. RoofArchitects Namgey Retty & Dorji Yangki
 - Architects Namgey Retty & Dorji Yangki (assistance by Architect Tempa Gyeltshen)
 - f. Rabsel - Architect Namgey Retty (assistance by Architects Dorji Yangki & Barun Chettri)
 3. Secondary Bhutanese Architectural Elements
 - a. Bogh and Phana
 - b. Pem and Choetse
 - c. Tshechu Khanyim
 - d. Norbu Bagum
 - e. Norbu Horzhu
 - f. Gyetsa
 - g. Keymar
 - h. Sertog
 - i. Gyeltshen
 - j. Lhadhar
 - k. Mythical AnimalsArchitects Namgey Retty & Dorji Yangki
 - Architects Namgey Retty & Dorji Yangki (assistance by Architects Jamyang S. N and Tshering Penjore)
 4. Proportion in Traditional Bhutanese Architecture - Architects Namgey Retty & Ugyen M Tenzin (assistance by Architects Tshering Phuntsho & Singay Daduel)
- Assistance with information, collection of photographs and drawings for Section One: Architects Kiyosato Kaneko, Architects from the Department of Culture- Nagtsho Dorji, Choening Dorji, Pema, Yeshey Samdrup, and Karma Tenzin and architecture student interns Tashi Norzim and Chusang Doma (who also provided assistance with the Chapters on Payab, Kachen and Zhu).
 - Architects Sonam Wangdi, Tandin Dorji, Sonam Tshering, Tilachand Timsine, and Tshering Norbu also provided assistance for Section One.
 - Architect Ugyen with guidance from Lopon Chang Dorji helped compile the Dzongkha -English Terminology.
 - Logistical support for administration and the Workshops for the Guidelines was provided by Kesang Jigme, PPD, MOWHS with assistance from Dago Retty.

SECTION TWO:

Coordination and information:

Architects Namgay Retty & Pem Gyaltzen

COMPILATION OF CHAPTERS:

Architects Namgey Retty, Pem Gyaltzen, Chhado Drukpa, Tashi Dema, Chador Y Yamtsho, Govind Sharma, Pashu Pati, Sunny Drukla, Sonam Tobgay, Yangchen Lhamu, Tshering Denka, Singay Daduel, with assistance from architecture student interns Deki Choden and Phuntsho Tenzin.

PREFACE

The traditional approaches to building and architecture are still very much alive in Bhutan especially in the rural villages. However, with the advent of modern development and exposure to external influences, these traditions are not shielded from challenges to its future. Bhutanese architecture and its future rest mainly on the understanding of values attached to it and consequent concrete actions taken to promote and develop these values.

It is through the awareness and understanding of these values that will motivate people to safeguard and develop it. Thus, they themselves become the best custodians of their own traditional practices and inheritance.

Taking the appropriate steps towards the development and promotion of Bhutanese architecture is of immense importance to Bhutan. Initiated by the Ministry of Works and Human Settlement “The Bhutanese Architecture Guidelines 2014” is a key constituent of the Royal Government of Bhutan’s objectives to ensure the conservation and development of Bhutanese architecture and its related values along with modern progress.

The Guidelines has been developed with funding support from the Royal Government of Bhutan, the World Bank and a grant from the Multi Donor Trust Fund for Cultural Heritage and Sustainable Tourism, funded by the Republic of India and Italy.

It is intended that the printed copies of the Guidelines will be distributed free of cost and will be available for free download on the website of the Ministry of Works and Human Settlement.





TABLE OF CONTENTS

ACKNOWLEDGEMENTS.....	6	RABSEL.....	114
PREFACE.....	7	RABSEL GO-CHAM.....	121
OVERVIEW OF THE GUIDELINES.....	11	(GO -CHHA) THOGNYIM.....	121
OBJECTIVES OF THE GUIDELINES.....	11	PAROP RABSEL.....	123
SCOPE AND LIMITATIONS OF THE GUIDELINES.....	11	BYELGO RABSEL.....	125
LAYOUT OF THE GUIDELINES.....	12	NYIMCHU RABSEL.....	127
ADMINISTRATION AND ENFORCEMENT.....	13	GOMANG RABSEL.....	129
AMENDMENT OF THE GUIDELINES.....	13	GYESARGO RABSEL.....	132
RELATIONSHIP TO OTHER REGULATIONS AND LEGISLATION.....	13	LINGO RABSEL.....	133
SECTION ONE.....	14	LOBUR RABSEL.....	134
TRADITIONAL ARCHITECTURE OF BHUTAN.....	16	SECONDARY BHUTANESE ARCHITECTURAL ELEMENTS.....	135
DZONGS.....	18	BOGH AND PHANA.....	136
LHAKHANG & GOENPA.....	28	PEM AND CHOETSE.....	137
ZANGDOK PELRI.....	32	TSHECHU KHA-NYIM.....	138
CHOETEN (STUPAS).....	34	NORBU BAGUM.....	139
PHODRANG (PALACES).....	38	NORBU HORZHU.....	142
YUE CHIM (DWELLING & FARMHOUSES).....	48	GYETSA.....	144
ELEMENTS IN BHUTANESE ARCHITECTURE.....	58	KEYMAR.....	147
MAIN ARCHITECTURAL ELEMENTS.....	59	NYIM KHEP.....	150
KACHEN AND ZHU.....	60	SERTO.....	152
KACHEN.....	63	GYELTSHEN.....	154
SQUARE –SHAPED KACHEN.....	64	LHADHAR.....	155
12 CORNER KACHEN.....	65	MYTHICAL ANIMAL SCULPTURES.....	156
CIRCULAR–SHAPED KACHEN.....	66	PROPORTION IN TRADITIONAL BHUTANESE ARCHITECTURE.....	158
OCTAGONAL –SHAPED KACHEN.....	67	BOGH AND PHANA.....	158
ZHU.....	68	PEM AND CHOETSE.....	161
GYALP DHEN ZHU.....	70	NORBU BAGUM AND NORBU HORZHU.....	162
ZHU JAAM TSHAB.....	72	TSHECHU KHA-NYIM.....	163
LANGNA DREY ZHU.....	73	RABSEL.....	164
JADHANG TAZI.....	76	SECTION TWO.....	168
PAYAB GOCHU.....	81	CONTEMPORARY ARCHITECTURAL GUIDELINES.....	168
HORGOPAYAB.....	84	2.1 KACHENS.....	170
LINGO PAYAB.....	88	2.2 PAYAB WINDOWS.....	186
GEDKAR PAYAB.....	91	2.3 RABSEL WINDOWS.....	192
BOEGO PAYAB.....	94	2.4 CORNICES.....	205
MAGO (DOORS).....	97	2.4 CORNICES.....	205
ROOF.....	102	2.5 ROOFS.....	211
JABZHI ROOF.....	106	RECOMMENDATIONS FOR ROOF DESIGN IN CONTEMPORARY BUILDINGS.....	214
JAMTHOK ROOF.....	109	2.6 OTHER ELEMENTS AND ISSUES.....	218
DRANGIM ROOF.....	111	ARCHITECTURAL THOBTHANG GUIDELINE FOR INDUSTRIAL AND OTHER BUILDING.....	219
CHENKHAP (LEAN TO ROOF).....	112	PROFESSIONAL COMMITTEE FOR ASSESSMENT.....	220
		BHUTANESE ARCHITECTURE DZONGKHA – ENGLISH TERMINOLOGY.....	221

OVERVIEW OF THE GUIDELINES

OBJECTIVES OF THE GUIDELINES

The main objectives of the Guidelines are:

- 1.To update and revise the exiting Guidelines of Traditional Bhutanese Architecture.
- 2.To ensure the sustainable development of the built environment in Bhutan without sacrificing local cultural heritage traditions and values that have been passed down over many generations and are integral to the social harmony and the tangible expression of the people of Bhutan.
- 3.To provide an easy reference on the intricate elements of local Bhutanese architecture for all architects, engineers and other stakeholders who will be influencing the built environment of Bhutan so that they will be equipped to incorporate local Bhutanese architectural elements into their new design and constructions accurately and appropriately according to these traditions.

SCOPE AND LIMITATIONS OF THE GUIDELINES

It should be noted that the Guidelines are not intended as a comprehensive and static document that will be restrictive to creativity in the built environment of Bhutan.

The Guidelines are meant to be used as a reference to understand the various elements of Bhutanese architecture and its values while providing a guide to what could be appropriate for new design and construction in Bhutan according to the values found in traditional architecture of Bhutan.

The Ministry shall make every effort to update and improve the Guidelines periodically with the help of Bhutanese Architects and relevant stakeholders.

LAYOUT OF THE GUIDELINES

The Guidelines is broadly divided into **2 Sections** as given below:

SECTION ONE:

Section One mainly outlines Bhutanese architecture and its elements as it has been for many centuries in the country.

Section One therefore reveals the traditional architecture of Bhutan in its vernacular state; the hierarchy of its elements; the proportion and forms of architectural elements to identify the building's values, function, and its significance.

All examples, pictures, illustrations and drawings within Section One consist of only those related to existing traditional Bhutanese architecture that have been in existence before modern development.

SECTION TWO:

Section Two focuses on new design and construction and the various considerations that should guide new design and construction.

Section Two finds its foundation in Section One but ensures that there is flexibility for creativity and innovation for new designs. Thus, instead of conserving local traditions in a static way, development and current requirements are taken into consideration.

All examples, pictures, illustrations and drawings within this Section Two consist only of those related to new design and construction.

ADMINISTRATION AND ENFORCEMENT

The administration and promotion of the Guidelines will be lead by the Ministry of Works and Human Settlement of Bhutan in consultation with relevant agencies, local architects, and other stakeholders.

The Ministry of Works and Human Settlement may identify the specific offices within the Ministry for the propagation and processes relevant to the Guidelines.

These offices will subsequently formulate necessary regulations and activities to take these Guidelines forward as Codes and Regulations within the different Sectors, Dzongkhags, and Thromde offices of Bhutan.

AMENDMENT OF THE GUIDELINES

The key to success in the built environment is the ability to change and adapt appropriately. Acknowledging that design and construction is an ongoing evolving process rather than static, the intent is that the Ministry of Works and Human Settlement will keep the Guidelines up to date.

It will therefore be reviewed, revised and publicly promulgated by appropriate professionals on a 2-year cycle or as required to allow for the integration of new and improved design and construction ideas, strategies and technologies in the built environment of Bhutan without undermining the local values and practices found in local Bhutanese architecture.

RELATIONSHIP TO OTHER REGULATIONS AND LEGISLATION

The Guidelines should be read and applied in conjunction with all existing and applicable Regulations, legal codes, Standards, Acts and Guidelines for land, buildings, products, infrastructure, environmental and cultural conservation of Bhutan.

It is the responsibility of those seeking approval to ensure that they are aware of all related current Acts, policies, legal codes and regulations and consider these for guidance and approvals from relevant authorities.



SECTION ONE

TRADITIONAL ARCHITECTURE OF BHUTAN

Gantey Goenpa
(Picture: Dorji Yangki)

SECTION ONE

The main objective of Section One is to provide information on traditional Bhutanese architecture that will provide guidance for the implementation of Section Two.

Section One therefore outlines traditional Bhutanese architecture and its design elements as they have been practised for many centuries in the country.

All examples, pictures, illustrations and drawings within Section One consist only of those related to existing traditional Bhutanese architecture that have been in existence before modern architecture development.

TRADITIONAL ARCHITECTURE OF BHUTAN

The traditional architecture of Bhutan is one of the most beautiful expressions of the ancient culture of the people of Bhutan. Harmonious proportions and graceful designs that reflect and mirror the integration of the simple daily lives of the Bhutanese people with the breath-taking landscapes of peaceful valleys and soaring mountains is a key nature of Bhutanese traditional architecture.

Large fortresses (called Dzong), temples (Lhakhang), monasteries (Goenpa), stupas (Choeten), palaces (Phodrang), bridges (Zam) and vernacular housing (Yue Chim) that dot the countryside of Bhutan form diverse examples of traditional Bhutanese architecture. According to recent records, the oldest standing buildings in Bhutan are Jambay Lhakhang in Bumthang, and Lhakhang Karpo and Nagpo in Haa. They are said to have been built around the 7th century.

Within Bhutanese building traditional practice, local carpenters (Zow) and masons (Dozop) managed the design and construction of buildings. It is often said that they were so experienced and skilled that they constructed buildings without the use of any design drawings on paper.

Their legendary skills are also reflected in the fact that indigenous buildings were constructed in the past without the use of a single metal nail, bolt or screw. The use of simple yet ingenious timber joinery techniques allowed them to achieve this way of construction.

The most distinctive elements of architecture of traditional Bhutanese buildings lie in following elements:

- The use of gentle tapering heavy walls made of stone or rammed earth and whitewashed in lime.
- The light “flying” gable timber roofs that hover in layers above the building.
- The design of light frames with elaborate timber windows and Rabsel built on the top floors over heavy walls below.
- The multi -tiered trefoil timber windows with Horzhu.
- The colourful timber lintels and cornices known as Bogh that mark the level and crown of each floor, window and door.
- The touch of local artists in the colourful floral, iconographic and spiritual paintings that embellish the interiors and the elevations of buildings.

Traditional architecture in Bhutan adapted over many centuries to suit the local environment, climate, materials, technology, and more significantly, cultural traditions and spiritual beliefs. Architecture in Bhutan was consequently adapted to satisfy not only functional and economical needs but also social and spiritual requirements. Inspired by nature, local natural materials such as earth, stone, timber, and bamboo are the core construction building blocks of traditional Bhutanese architecture.



Village on the way to Gasa (Picture: Dorji Yangki)

DZONGS

Fortresses known locally as Dzong are architectural masterpieces and are by far some of the most impressive and majestic forms of architecture in Bhutan.

The Bhutanese word Dzong loosely translates as "fortress". With its primary objective of defence, the site selected for a Dzong was usually a commanding one, generally on a strategic ridge overlooking the entrance to a valley.

Dzongs in Bhutan are in use today as they were for many centuries as centres of administration and religious practice. Each Dzong in a Dzongkhag therefore houses the offices of the local Government and residences of the local monastic body. They are therefore not silent static museums.

As the most prominent building in a region, Dzongs were, and continue to be architectural trendsetters for other buildings in Bhutan.

Dzongs are considered treasure houses of magnificent paintings, murals, carvings, sculptures, ancient hand printed manuscripts, rare artefacts, and textiles. Some of the best examples of Bhutanese artistic achievements, paintings and craftsmanship are thus found in the Dzongs.

In terms of historical importance, Dzongs are the most significant tangible symbols of the history of Bhutan. Dzongs were the seats of powerful leaders and often, great historical battles and events took place in or around a Dzong.

They thus played vital roles in establishing the identity and independence of the Bhutanese.

A particularly important association that Dzongs epitomise is the historic dual system of governance and power shared harmoniously between a secular leader and a religious leader that still exists today.

The main Dzong that stand today are attributed to the great historical and religious leader Zhabdrung Ngawang Namgyel (1594-1651) who is credited with the construction of some of the greatest Dzongs in Bhutan including the Semtokha Dzong, the Punakha Dzong, and the Trongsa Dzong.

DZONGS IN WESTERN BHUTAN

Punakha
Dzong



Trashicho
Dzong

Semtokha
Dzong

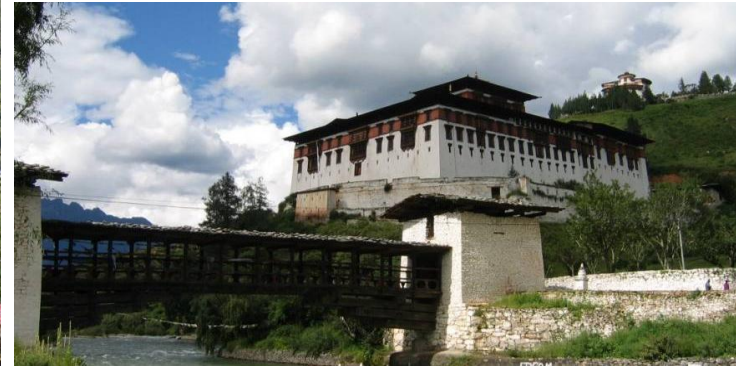

Paro
Dzong

Haa
Dzong



Gasa
Dzong

(Pictures: Punakha Dzong- Namgey Retty, Trashichodzong- Dago Retty; Rest of Dzongs- Dorji Yangki)

ANCIENT DZONGS IN EASTERN BHUTAN

Trongsa
Dzong



Tashigang
Dzong



Jakar
Dzong

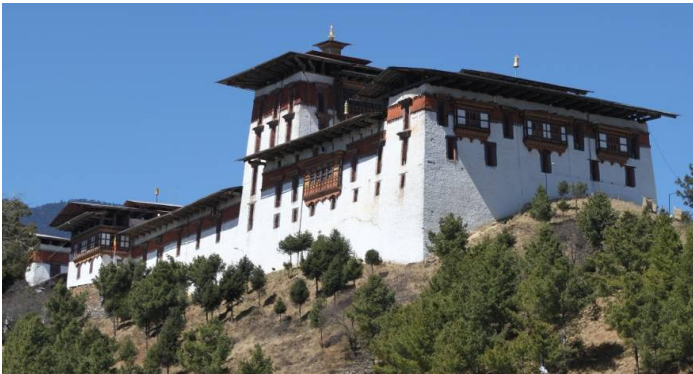

Lhuntse
Dzong



(Pictures: Trongsa Dzong- Namgey Retty; Lhuntse Dzong-Masa; Rest of the Dzongs-Dorji Yangki)

Architectural Layout of a Dzong

The layout of a Dzong was typically designed as a simple square or a rectangle based on the terrain and space available on site. The central towering structures in the centre of a Dzong known as Utse are usually built up to three or more floor levels in the centre of courtyards enclosed by rooms spread on all sides to form a secure enclosed structure. Deviations from this pattern were generally due to differences in terrain.

The structure of a Dzong consists usually of heavy load-bearing walls of stone masonry, gradually tapering up from the foundations to the roof. Timber was the main material used in all other architectural elements including the windows, doors, flooring, railing, stairs, ceilings, and roofing structure.

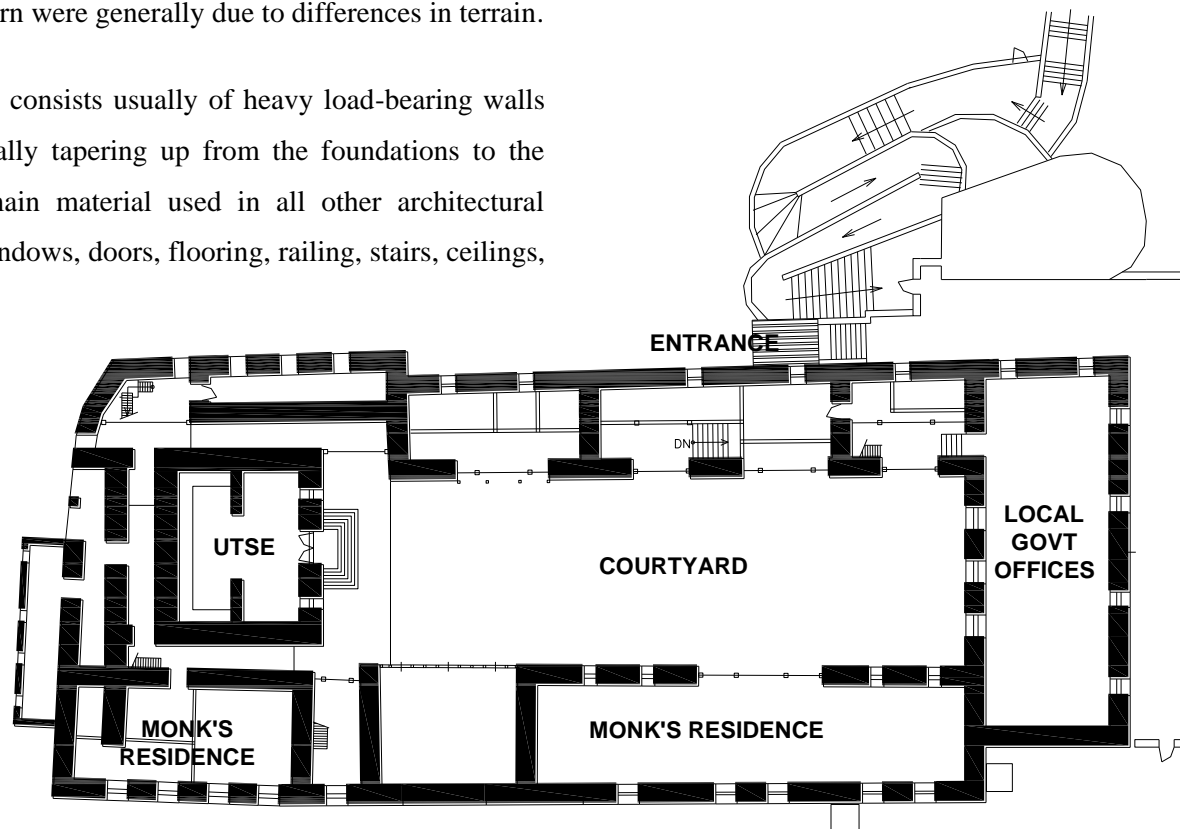

Lhuntse Dzong Layout Plan
(Drawing: Dept. of Culture)

The Utse, located in the centre of the courtyard, forms the core of a Dzong and is where the main temples are usually located.

Along the sides of the courtyard, the outer structure of the Dzong is usually two or three storied with decorated arcades facing the courtyard.

These structures house the living quarters and other spaces for the monks in one part of the Dzong and the administrative offices of the local government in the other side.

As there is a clear division between the monastic and administrative parts of the Dzong, there is sometimes one courtyard for each part.



Utse at
Punakha Dzong
(Picture: Namgye Retty)



Wangduephodrang
Dzong Courtyard
(Picture: Dorji Yangki)

ELEVATION, PLAN AND PICTURE OF SEMTOKHA DZONG

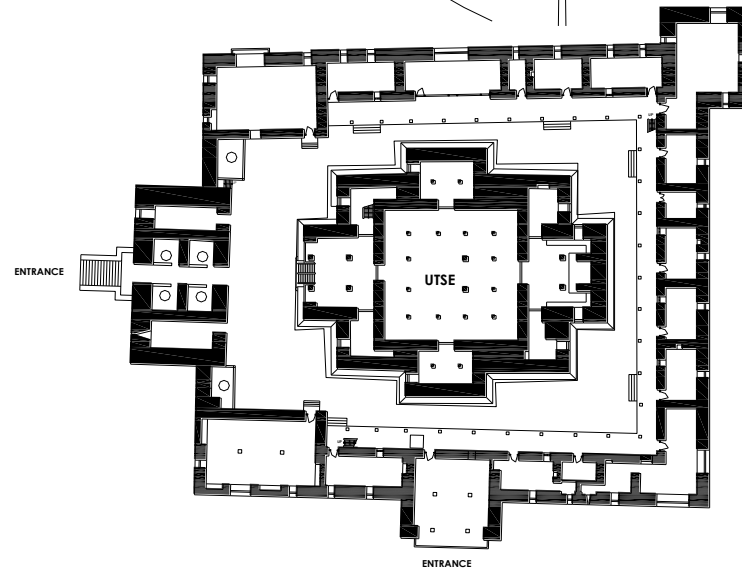
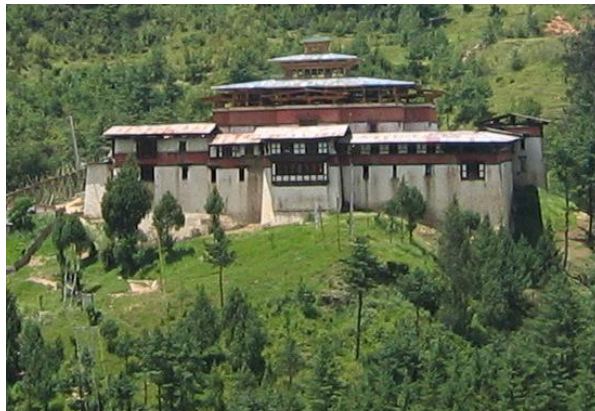
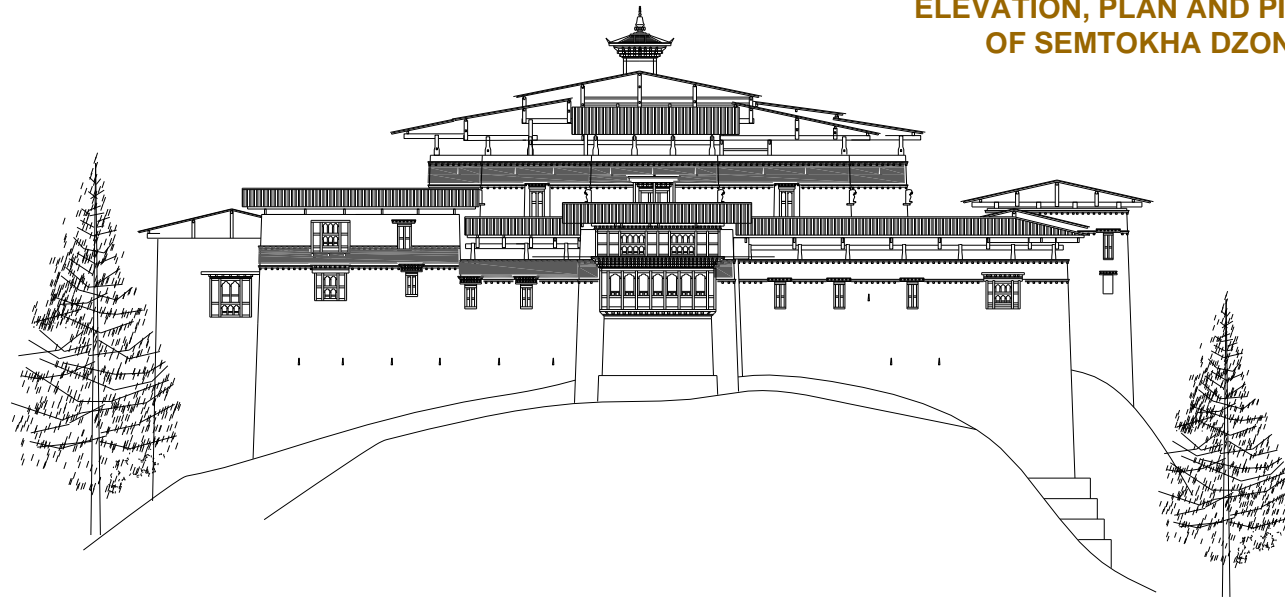

(Drawing: Dept of Culture Semtokha Project; Picture: Dorji Yangki)

PUNAKHA DZONG

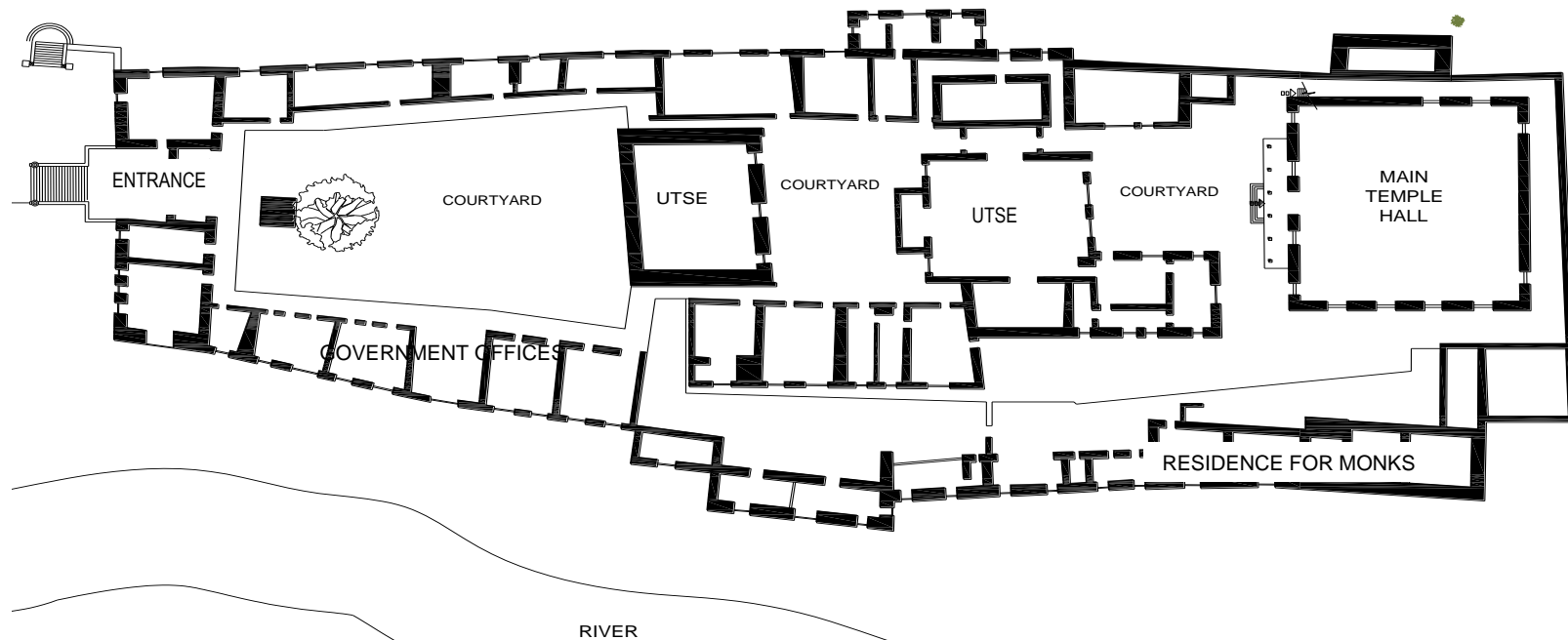
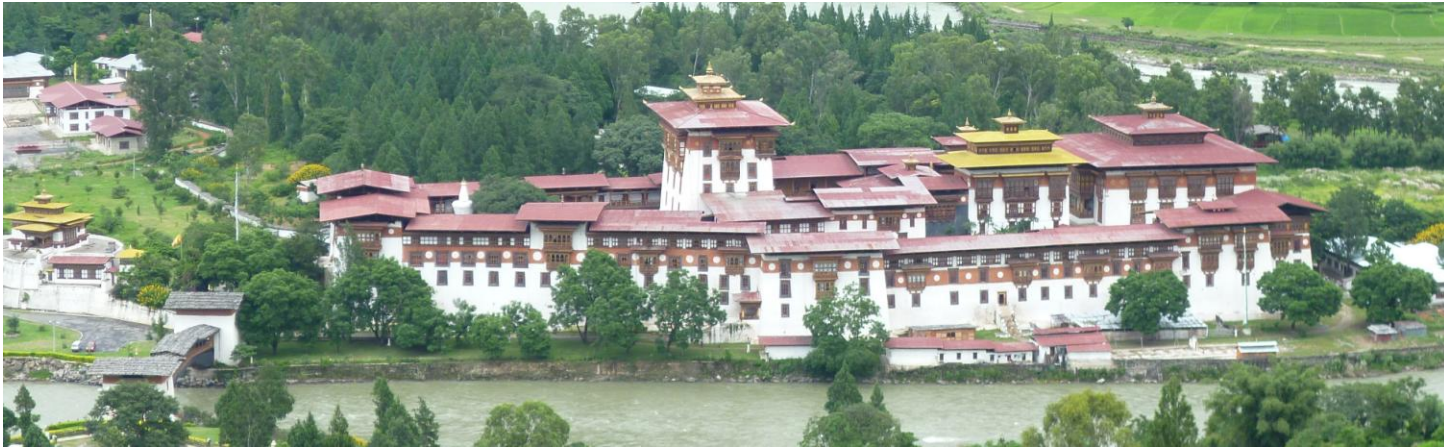

PUNAKHA DZONG FLOOR LAYOUT PLAN
(Drawing: DCAH, Dept of Culture; Picture: Dorji Yangki)

TRASHICHODZONG PLAN & ELEVATION

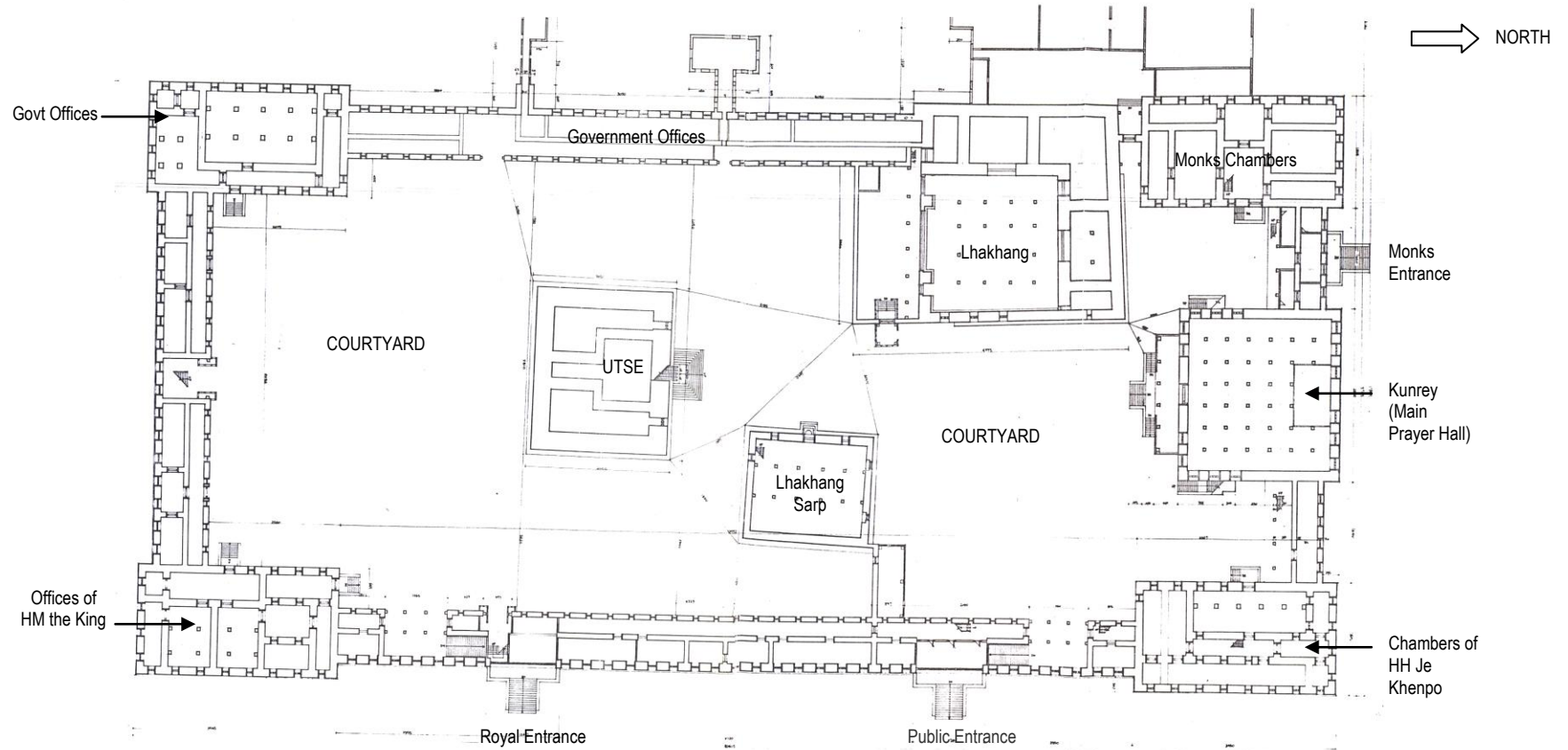

(Plan Drawing: Kiyosato Kaneko
Elevation Drawing: Dept of Culture)

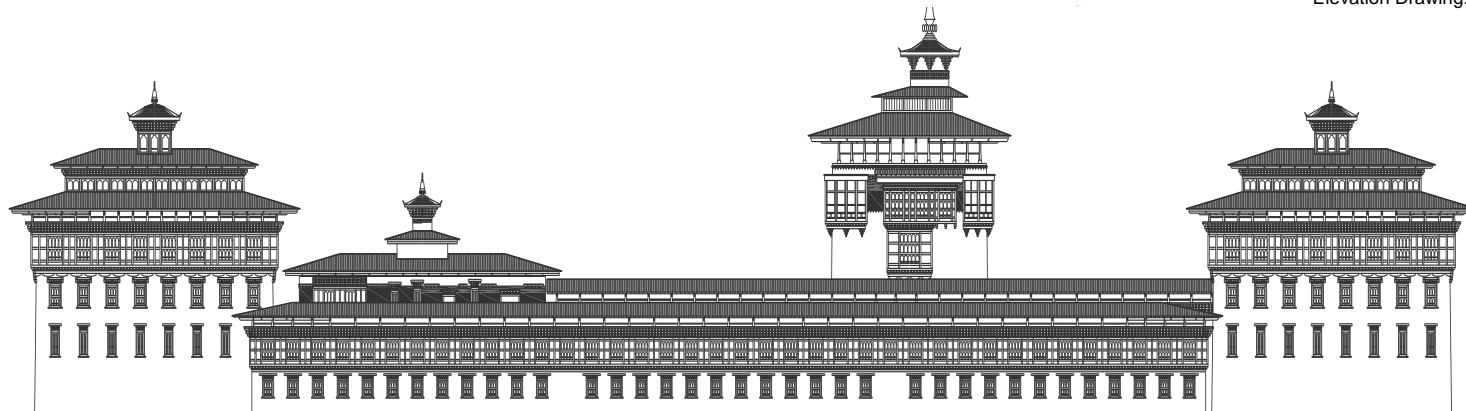



TRASHICHODZONG UTSE DETAILS

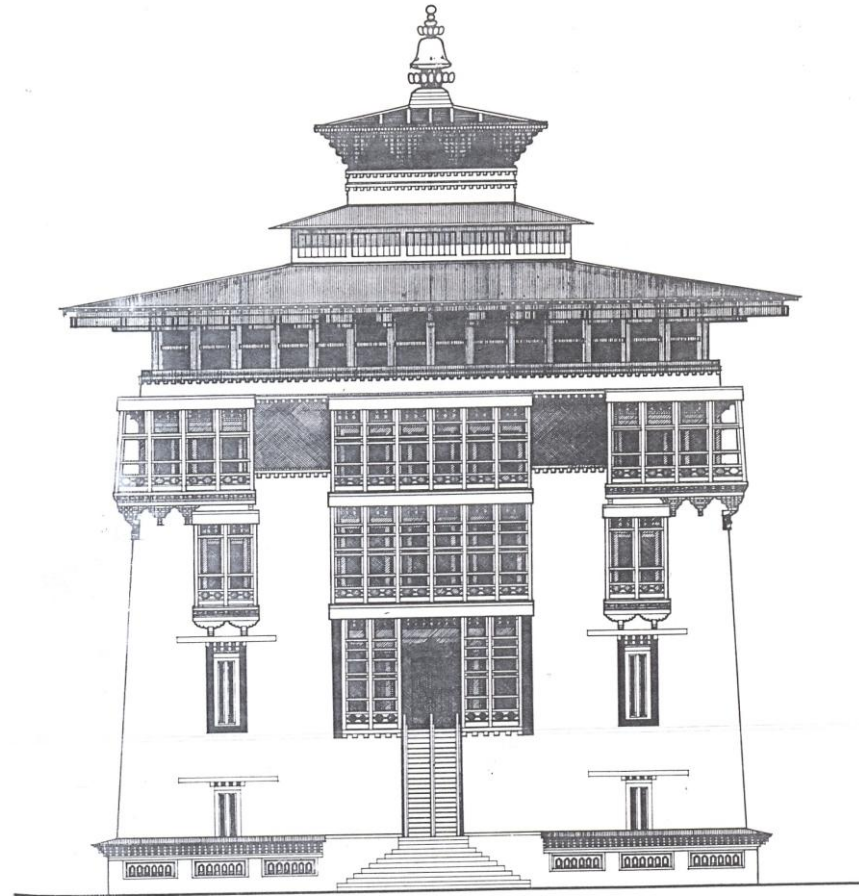

TRASHICHODZONG UTSE FRONT ELEVATION

Drawing: Kiyosato .Kaneko; Picture: Dorji Yangki)

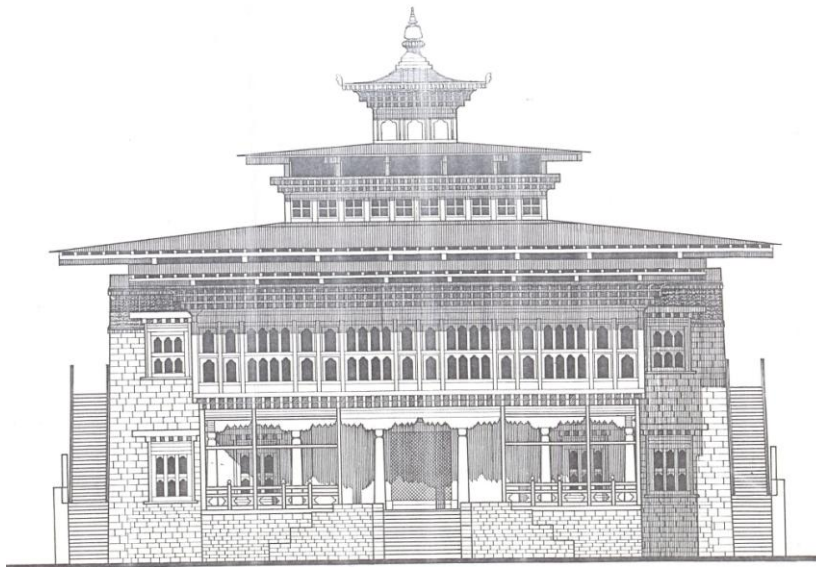

KUNREY LHA KHANG

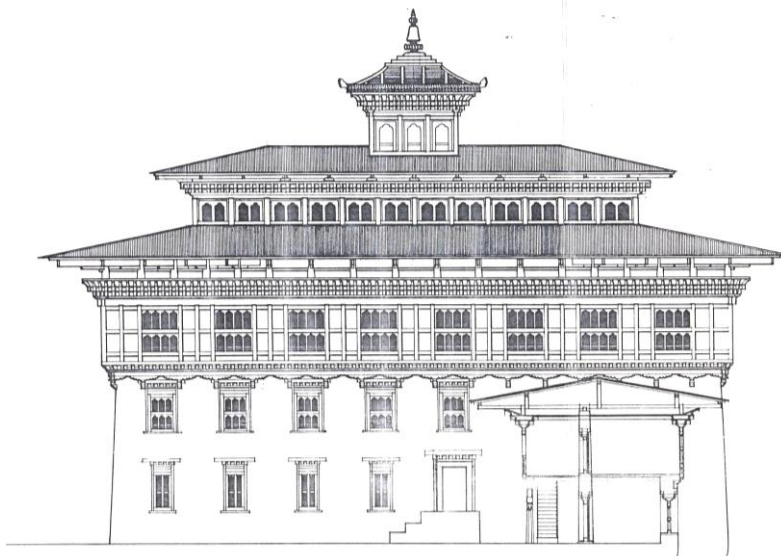

SOUTH EAST TOWER

TRASHICHODZONG BUILDING DETAILS



(Drawing: Kiyosato Kaneko; Picture: Dorji Yangki)

LHAKHANG & GOENPA

With over two thousand Lhakhangs (Temples) and Goenpa (Monasteries) in Bhutan, they can be found in almost every village and on almost every mountaintop in the country. Although they do not match the soaring proportions of the *Dzongs*, many Lhakhang and Goenpa are older than Dzongs, with some dating as far back as the 7th century.

Usually, within a village, the Lhakhang is the most prominent building. Besides being religious centres, they also have important social and cultural functions as almost all village cultural events are held there. The Buddhist Lhakhang is usually a simple hall with an entrance foyer and a main hall holding the main altar of the temple. Besides the main temple building, simple buildings with rooms for the monks are constructed.

Often the layout of a Goenpa monastery consist of a one or multiple storey temple building in the centre of a simple courtyard flanked by structures used for the living quarters of the monks.



Konchusum
Lhakhang in
Bumthang



Kichu
Lhakhang
in Paro

Two of the oldest Lhakhang in Bhutan that date back to the 7th century

GANTEY GOENPA IN WANGDUEPHODRANG

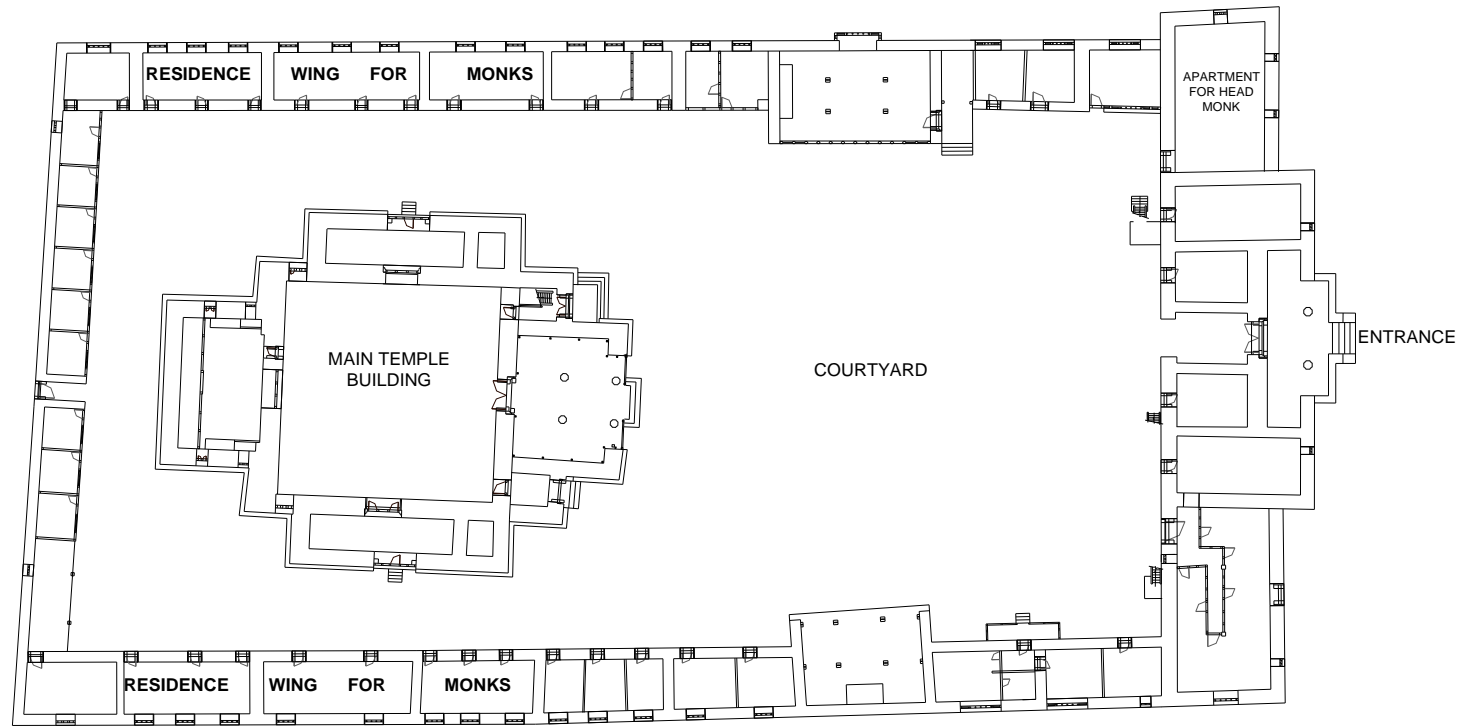

(Drawing: Dept of Culture) (Picture: Dorji Yangki & Namey Retty)

SOME OF THE MOST SACRED TEMPLES IN BHUTAN



Row 1: Taktshang Monastery in Paro and Tamshing in Bumthang (Pictures: Dorji Yangki)

Row 2: Goma Kora Lhakhang in Trashi Yangtse and Chimi Lhakhang in Punakha (Pictures: Dorji Yangki; Kesang Jigme)

**PLAN, ELEVATIONS & SECTION
OF A TYPICAL BHUTANESE LHAKHANG**

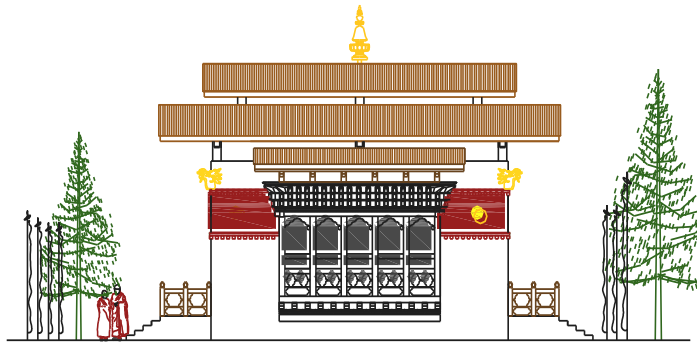

FRONT ELEVATION

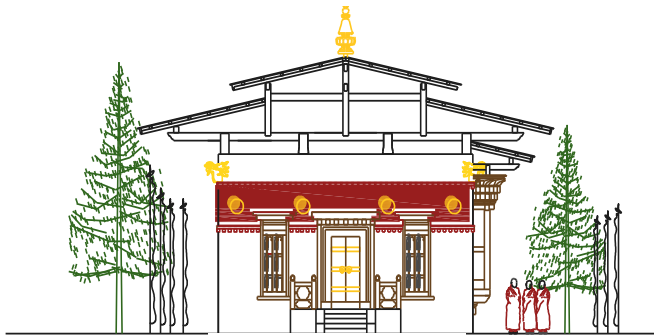

SIDE ELEVATION

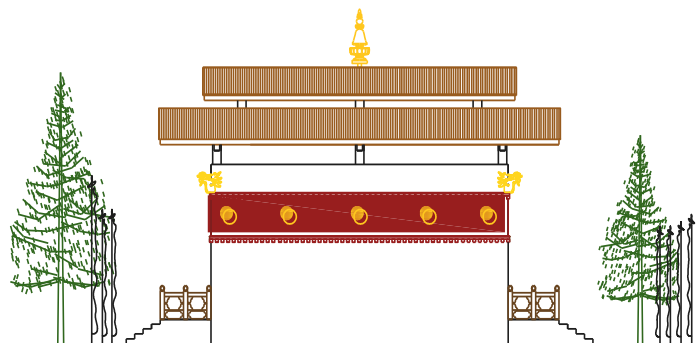

BACK ELEVATION

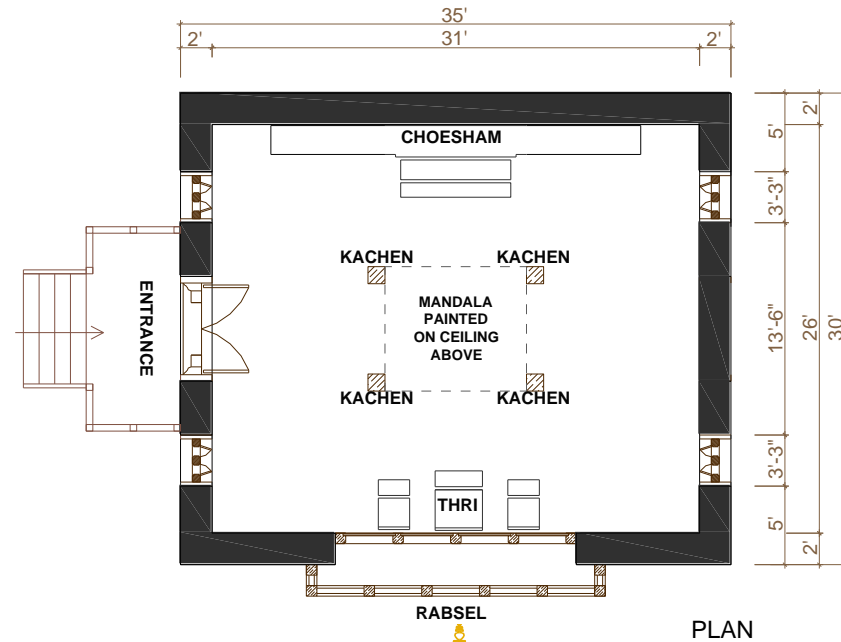

PLAN



SECTION

(Drawings: Dorji Yangki)

ZANGDOK PELRI

The Zangdok Pelri temple is a special type of temple design that looks like an amalgamation of a Lhakhang and a Choeten (Stupa).

The design of the temple is representative of the celestial palace of Guru Padma Sambhava. Zangdok means copper coloured and Pelri means mountain or palace. The Zangdok Pelri building consists of the following:

1. Ground Level

The Ground Floor of a Zangdok Pelri represents the “Outer level” of celestial palace called the Nirmanakaya. In this hall is usually where the main statue of Guru Padma Sambhava seated on a lotus throne is surrounded by his eight manifestations is installed in the centre of the room

2. Middle Floor

The Middle Floor of a Zangdok Pelri represents the “Inner level” of the celestial palace known as the Sambhogakaya Mansion. The space here usually houses the statue of the Avalokiteshvara (Chenrigzig) surrounded by the Eight Noble Bodhisattvas.

3. Upper Level

The topmost floor of a Zangdok Pelri represents the “Inner most” of the celestial palace, which is the “Secret” level known as the Dharmakaya Mansion. The upper level is where the statue of Lord Vairocana surrounded by the Family of Five Primordial Buddhas is installed.



FLOOR PLAN, ELEVATION AND SECTION OF
A TYPICAL ZANGDOK PELRI

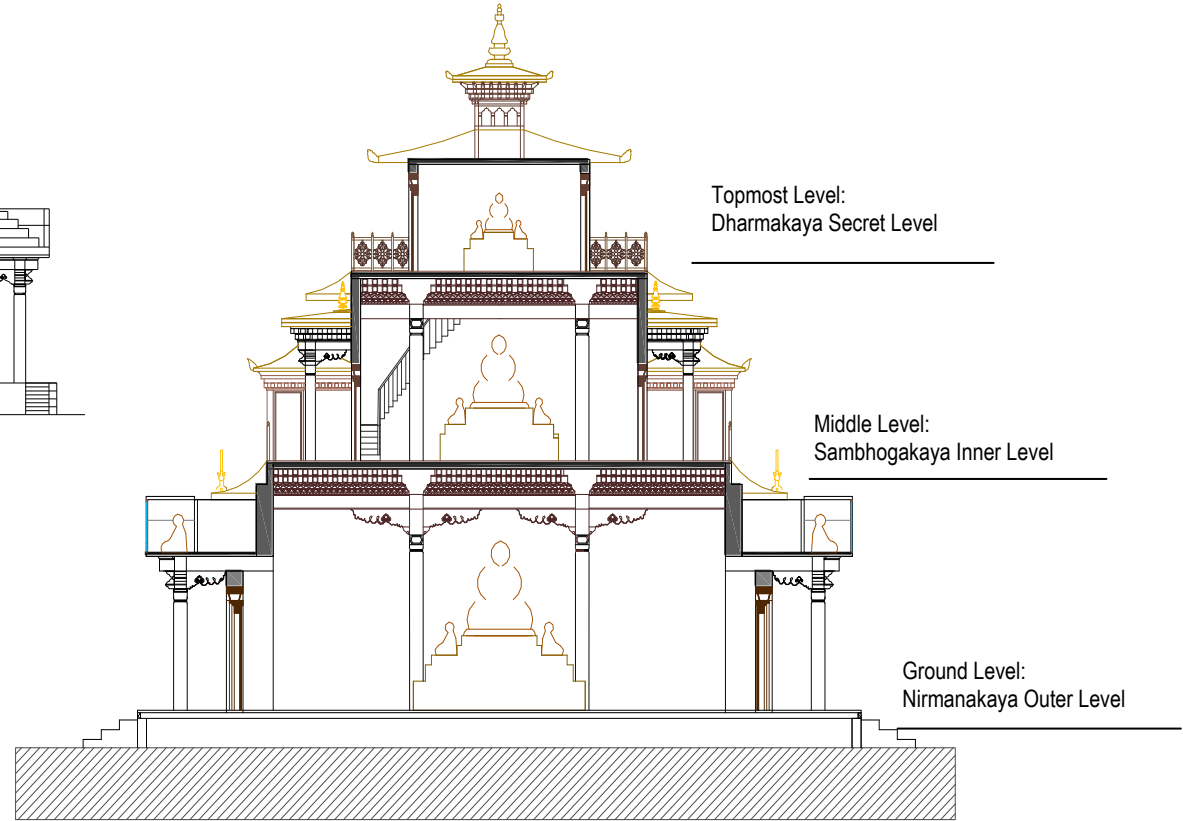
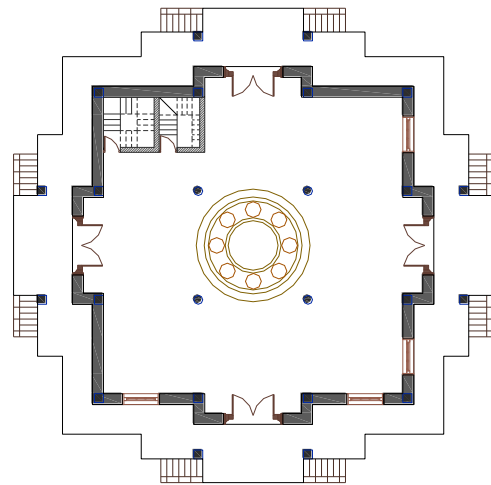
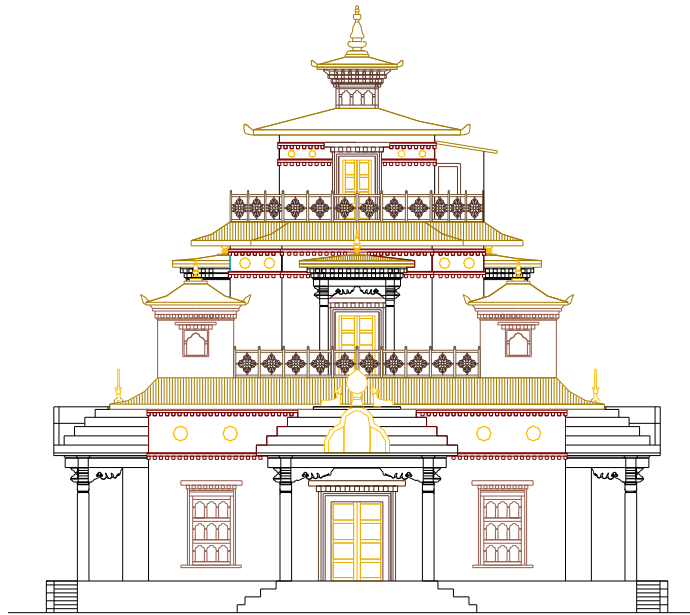

(Drawing: Dorji Yangki)

CHOETEN (STUPAS)

With over ten thousand Choeten, these traditional structures are the most common spiritual heritage structures found in Bhutan. Choetens were built to represent receptacles of the relics of the Buddha and important saints and monks. They were also built in places where negative energies and spirits needed to be turned into positive forces. Choetens are found practically everywhere in Bhutan. They are found located mainly on high mountain passes, on roads, on approaches to important locations and buildings, and even on bridges.

Choetens range from as small as 2 metres to over 10 metres in height. Choeten are sometimes linked by long thick walls called *Mani* (prayer) walls, which are inscribed with religious paintings and prayers. Choetens are built mainly of stone and mud mortar. The inner part of the structure of a Choeten is usually kept hollow and filled with important and sacred elements including a square post called Sokshing (post or tree of life) which is made of timber that is inscribed with prayers and religious illustrations.

Choetens can be designed in a very basic way without any embellishment or decorations. They are also designed in very elaborate ways with slate carvings, carved cornices, and embossed gold frames and pinnacles.

Although there are many different types of Choeten in Bhutan, the typical Bhutanese Choeten is known as Khangzha and is square in shape with a hip roof of stone. The Square Bhutanese Choeten is always marked with a red band called Keymar around the upper level of its walls to signify its spiritual status.



EXAMPLES OF THE BODNATH STYLE CHOETEN IN BHUTAN



Choeten
at Talo,
Punakha



Choeten
at Trashi
Yangtse



Choeten
at Kurje
Lhakhang,
Bumthang



Chendibji
Choeten
at Trongsa

(Pictures: Dorji Yangki)

EXAMPLES OF THE TYPICAL BHUTANESE STYLE SQUARE CHOETEN IN BHUTAN



Choeten near
Wangduephodrang
Dzong



Choeten
at Dochula



Choeten
near
Semtokha
Dzong



Choeten
below
Paro Dzong

(Pictures: Dorji Yangki)

CONCEPT PLAN AND ELEVATION OF A TYPICAL BHUTANESE KHANGSAR CHOETEN

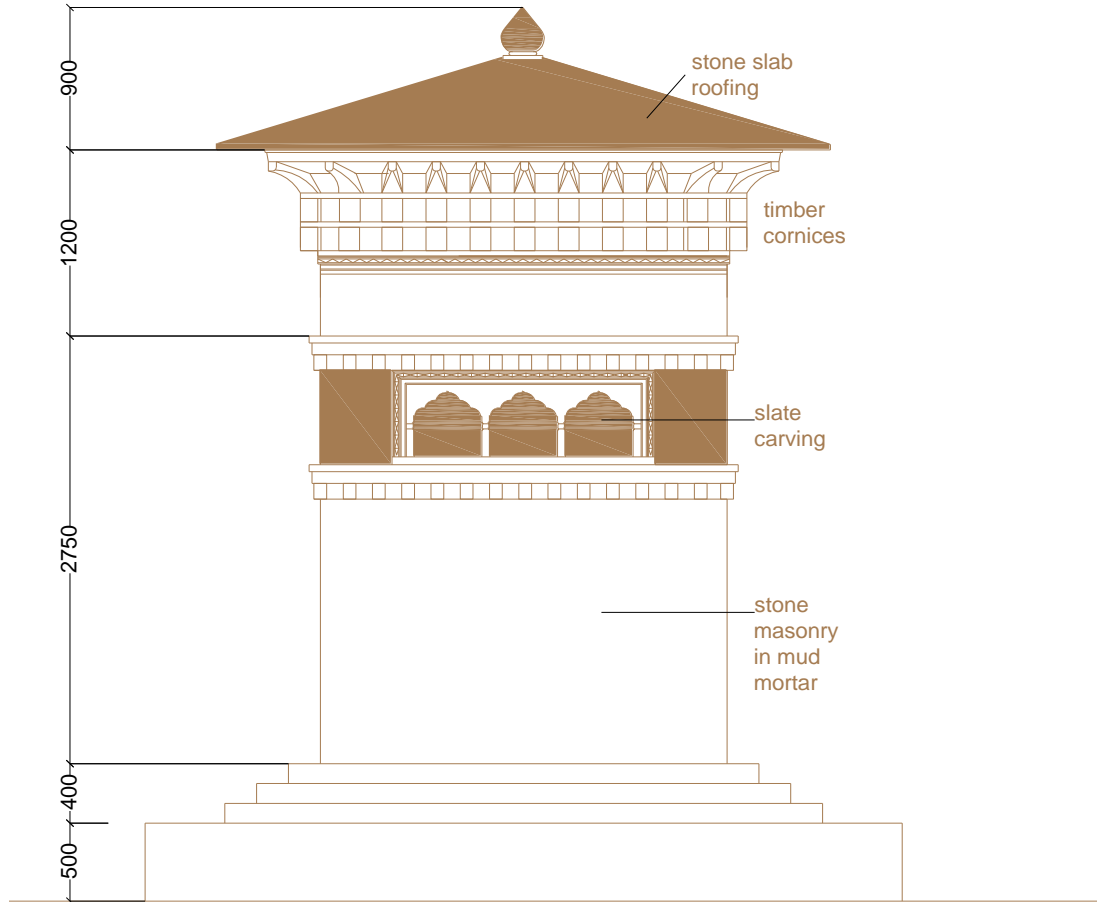

ELEVATION

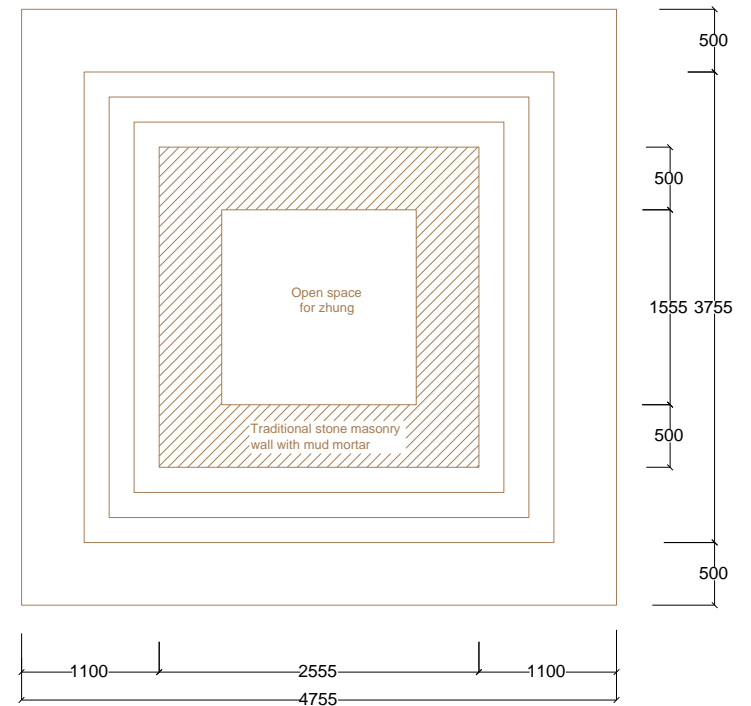

PLAN

(Drawing: Dorji Yangki)

PHODRANG (PALACES)

The architecture of Phodrang is very similar to the architecture of Dzongs. The most famous palaces that stand today were built during the time of the first and second Kings of Bhutan. These include the Wangduecholing and Lami Goenpa Palaces in Bumthang, Ugyen Pelri palace in Paro, Kuenga Rabten and Samdrupcholing

palaces in Trongsa. The Dechencholing Palace in Thimphu, which was built during the time of the third King of Bhutan, is also known for its beauty and graceful serenity.

The layout of a typical Phodrang included a main temple within the central Utse in the centre of a courtyard with chambers for the King,

the royal family and main officers and attendants around the courtyard. The quarters for the servants and stables were usually built outside the main palace building. The palaces of Bhutan are known for their graceful beauty and have some of the finest and unique designs, craftsmanship, paintings and carvings.



Left: Ugyen Pelri palace in Paro (Picture: Dorji Yangki)
Above: Dechencholing Palace (Picture: Chang Dorji)

WANGDUECHOLING PALACE

The Wangduecholing Palace in Bumthang which was built around 1857 by the great historical figure Gongsar Jigme Namgyal, the father of the first King of Bhutan and Trongsa Penlop, is known for its unique architectural beauty and historical significance. When Gongsar Ugyen Wangchuck was crowned the King of Bhutan in 1907, it became the palace of the King and the first courts of the Wangchuck dynasty were started there.



(Picture: Dorji Yangki)



Wangduecholing palace
(Pictures: Dorji Yangki)



Utse of Wangduecholing Palace
(Picture: Dorji Yangki)

LAYOUT PLAN OF WANGDUECHOLING DZONG

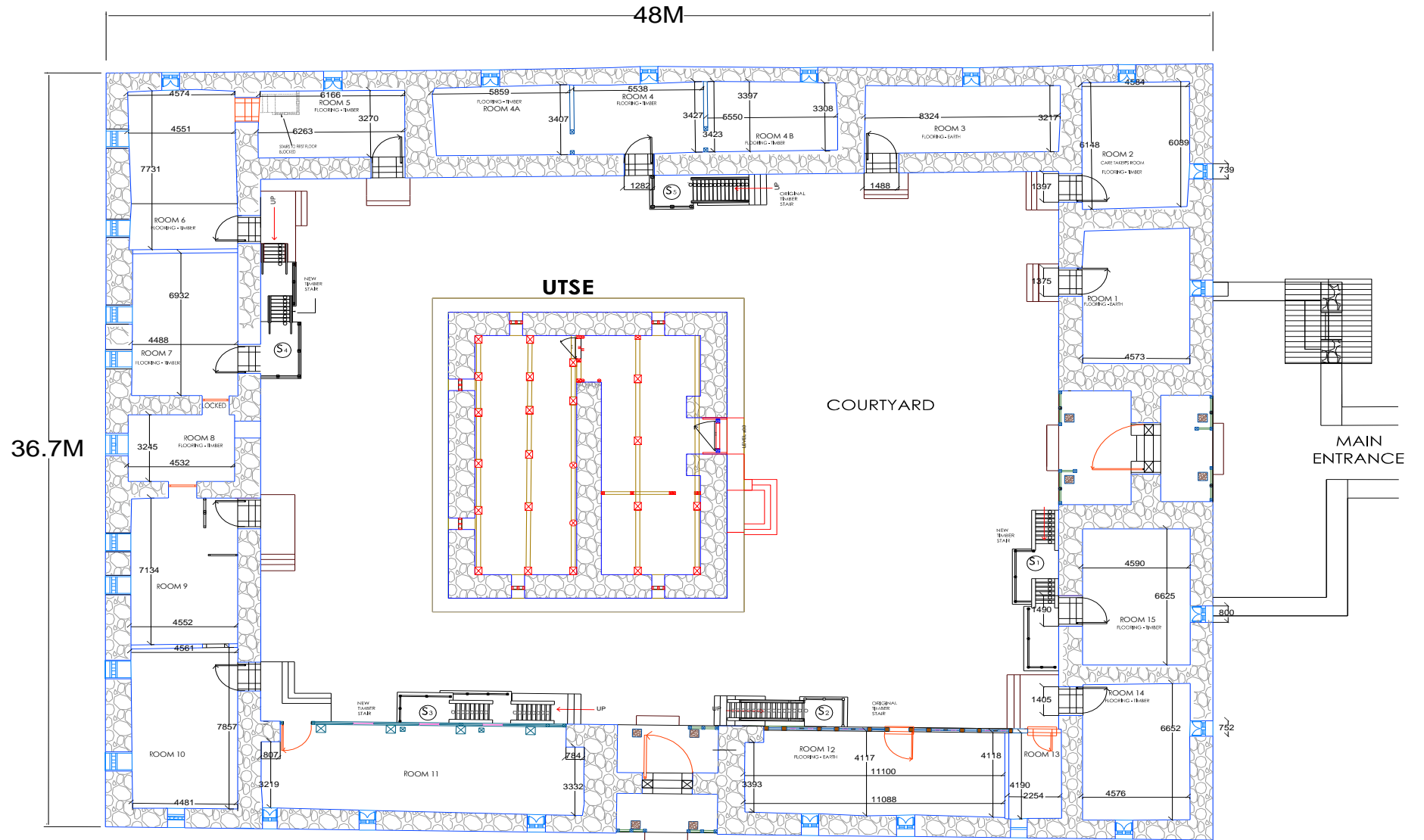

(Drawings: Yalama Consultancy)

**ELEVATION DRAWINGS OF
WANGDUECHOLING
PALACE IN BUMTHANG**

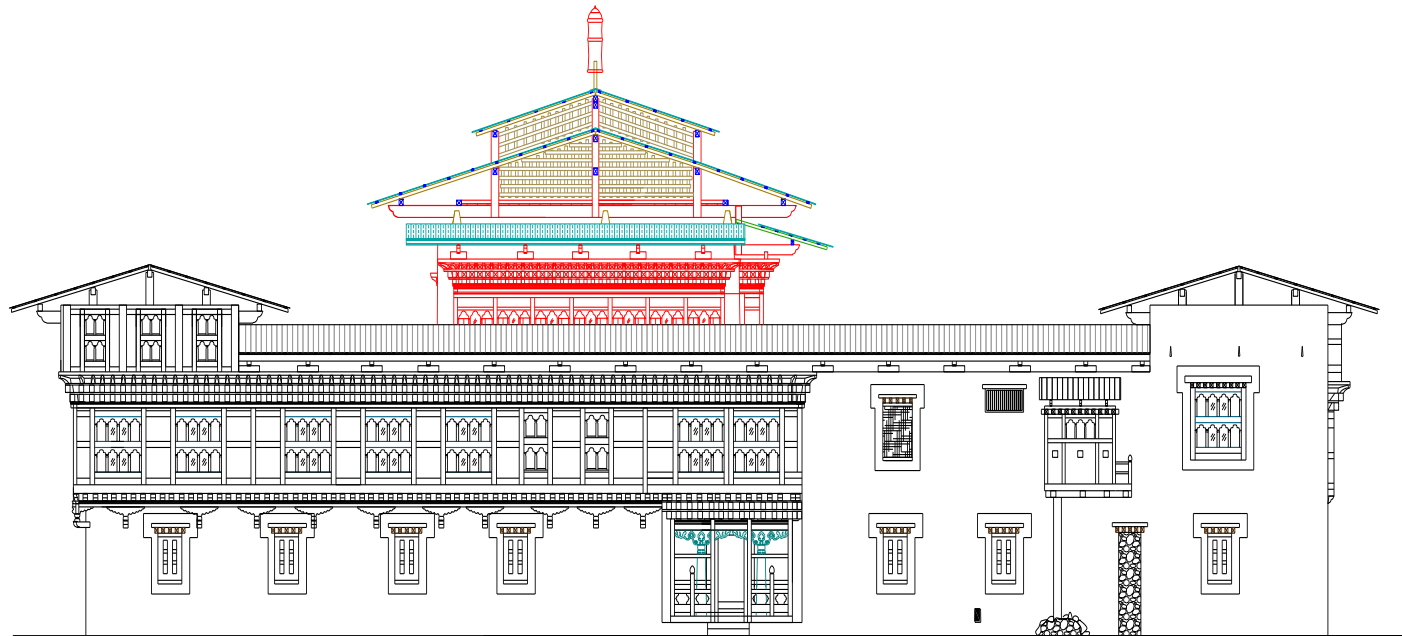
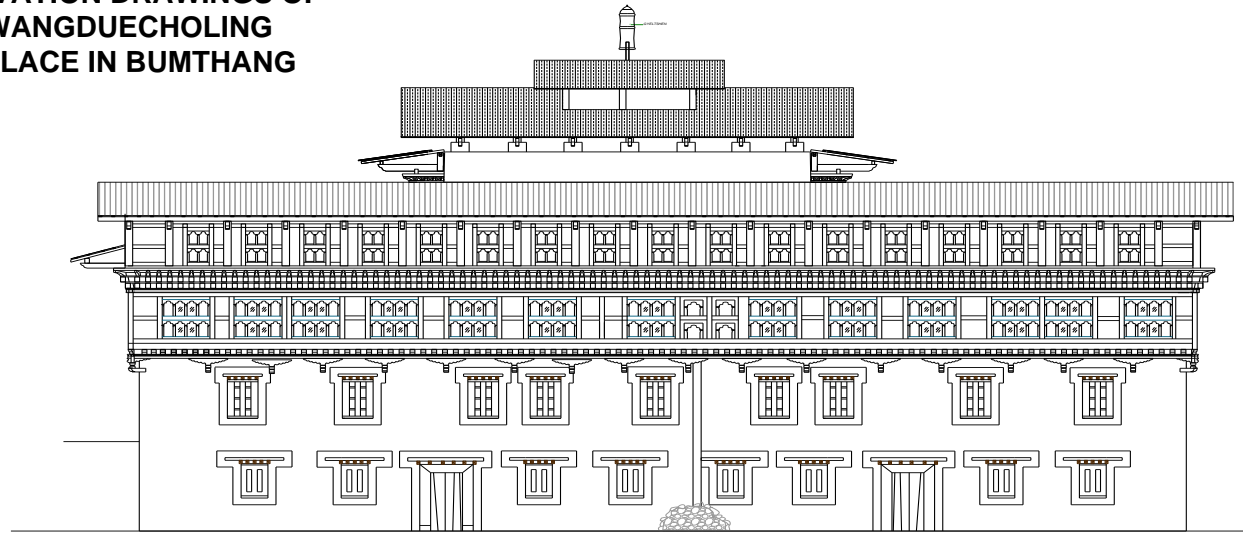

(Drawing: Yalama Consultancy)

KUENGA RABTEN PALACE IN TRONGSA





Rabsel at Kuenga Rabten



Beautiful Timber Carving Details at Kuenga Rabten Palace
(Pictures of Kuenga Rabten: Dorji Yangki)

DUNGKHAR NAGTSHANG IN LHUNTSE DZONGKHAG



(Pictures: Dorji Yangki)

YUE CHIM (DWELLING & FARMHOUSES)

Secular architecture in Bhutan finds its main form in traditional farmhouses that form small clusters in tiny villages. A Bhutanese home is not only a residential unit but also a social, economic and religious unit. Apart from providing a home for the family and shelter for domestic livestock, it was also an extension of the religious space of a temple.



TYPICAL DIVISION OF SPACES IN A TRADITIONAL BHUTANESE HOUSE

The arrangement of spaces within an indigenous Bhutanese house is extremely functional. An ideal traditional house was one that had three main floors and an attic, with each level having distinctive functions. Spaces due to functional demarcations were normally laid out in a vertical hierarchy, which start from the simple lower ground floor spaces used

for sheltering livestock, to the storehouses for products from the farms in the middle level to the sacred upper level spaces, used for sleep, family, guests and spiritual rituals. Spaces in traditional Bhutanese homes are designed to be functional yet flexible. Spaces usually flow organically from one room to the other in a relationship that brings the residents together.

The division of spaces are typically arranged as follows:

- | | | |
|-----------------------------|---|----------|
| a. The Compound / courtyard | - | Gagona |
| b. The Ground Floor | - | Wothok |
| c. The Middle Floor | - | Barthok |
| d. The Upper Floor | - | Taenthok |
| • The Kitchen | - | Thabsang |
| • Deck | - | Nyimchu |
| • The Living room | - | Yuelkha |
| • The Prayer room | - | Choesam |
| e. The Attic | - | Yotoka |



Rammed earth house in Thimphu
(Picture: Dorji Yangki)

TYPICAL FORM OF A BHUTANESE HOUSE:

The built form of indigenous houses generally consists of a light thin structure suspended and floating above a heavy massive box-like structure. These forms project out from the land and are notable in that they do not seem to try to simulate the natural curves and slopes of the hills and valleys that make up the natural topography of the land. This box-like built form is seen to have come about due to the following main reasons:

- The influence of the local materials used.
- The simple local technology used for construction.
- The climatic conditions of the land.
- The functional and spiritual demarcations of spaces.

The natural climate and topography of the place and the use of local natural materials like rammed earth for the walls were the main aspects that determined the formation of the built form of indigenous houses. In the past, lack of technology to produce curved formwork, that would allow rammed earth walls to have curved ‘organic’ forms, restricted formwork to box-like forms which gave rise to straight regular walls that were joined together in straight angular corners.

The shape of the buildings could also be a response to the climatic conditions of the land. The box-shape of the houses meant that there was a smaller ratio of surface area to volume thus lesser area of the building envelope was exposed to the cold climatic conditions leading to a smaller amount of heat loss than there would be with a single storey ‘ranch style’ building form.

The wide overhangs of the roof came about from the need for protection to the earth walls and timber structures from the heavy rainfall during the monsoon season. To help to drain rain, during the monsoon, and snowfall, in winter, the roof had to be designed with an inclination. To prevent stones, which were used in the absence of nails to hold down timber shingles used for roof cover, from rolling off the roof, the inclination of the roof could not be too steep and was thus kept to around 11° to 13°.

The absence of refrigeration meant that food for the winter months was dried for preservation. A space that was secure, clean and had good ventilation was needed for this drying process. An attic that was open to the environment thus came about leading to the roof being suspended above the ceiling to create this space. This space was also used to store feed for animals.

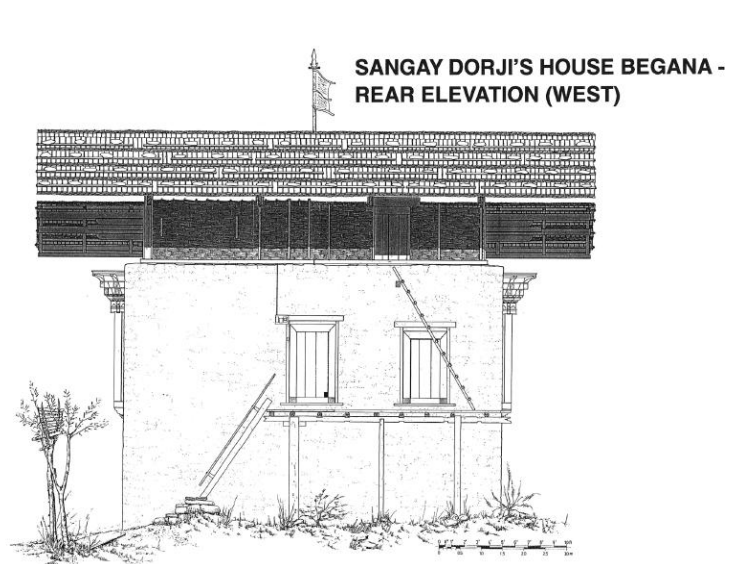

THE HOUSE OF SANGAY DORJI AT BEGANA - BHUTAN by Mark Dujardin UNCHS, 1990 23

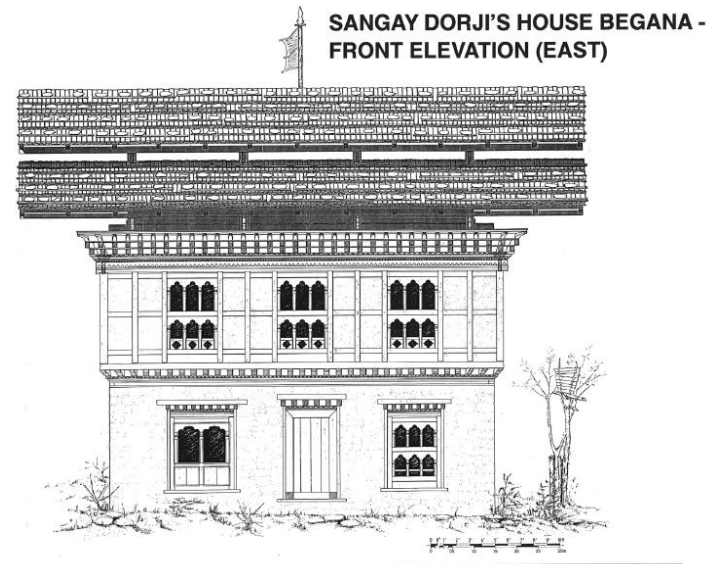

THE HOUSE OF SANGAY DORJI AT BEGANA - BHUTAN by Mark Dujardin UNCHS, 1990 20

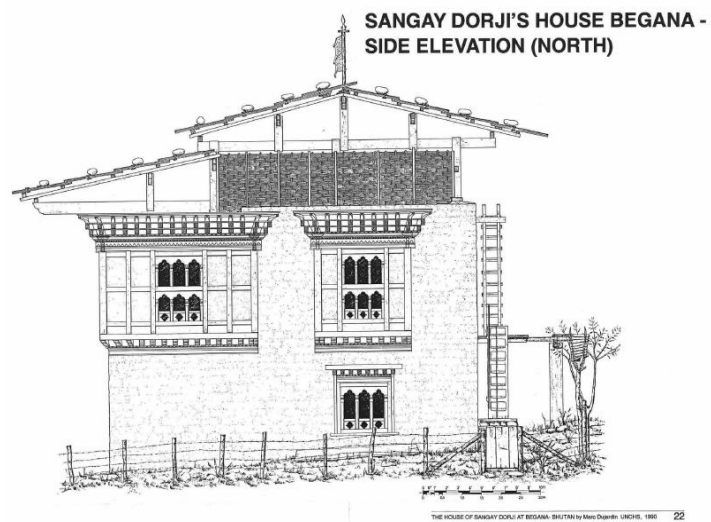

THE HOUSE OF SANGAY DORJI AT BEGANA - BHUTAN by Mark Dujardin UNCHS, 1990 22

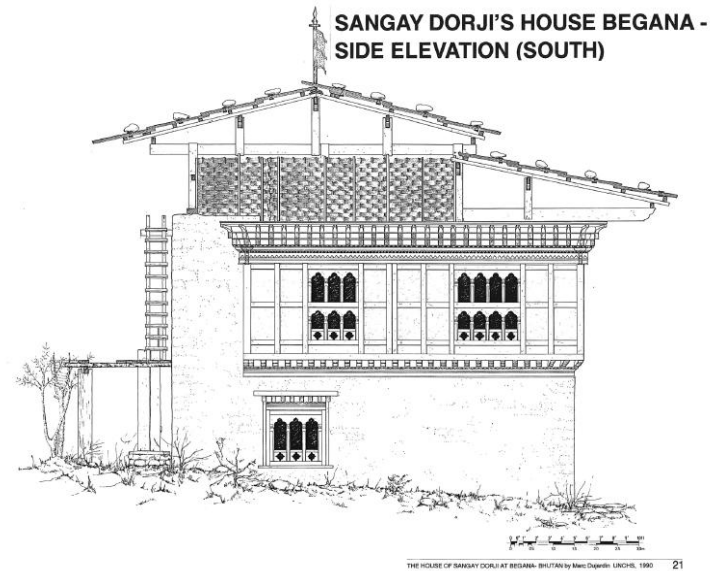

THE HOUSE OF SANGAY DORJI AT BEGANA - BHUTAN by Mark Dujardin UNCHS, 1990 21

(Drawings by Mark Dujardin)

TRADITIONAL HOUSES IN BUMTHANG



(Pictures: Dorji Yangki)

TRADITIONAL HOUSES IN PARO



(Pictures: Dorji Yangki)

TRADITIONAL HOUSES IN HAA DZONG KHAG



(Pictures: Dorji Yangki)

TRADITIONAL HOUSES IN THIMPHU



(Pictures: Dorji Yangki)

TRADITIONAL HOUSES IN WANGDUEPHODRANG



(Pictures: Dorji Yangki)

TRADITIONAL HOUSES IN LHUNTSE



(Pictures: Dorji Yangki)

ELEMENTS IN BHUTANESE ARCHITECTURE

Architectural elements in traditional Bhutanese architecture enhance or upgrade the hierarchy and values of a design. The architectural elements in traditional Bhutanese architecture may be divided into two categories. They are the following:

- 1) Main Architectural Elements and
- 2) Secondary Architectural Elements

MAIN ARCHITECTURAL ELEMENTS	SECONDARY ARCHITECTURAL ELEMENT	
<p>The Main Architectural Elements are those that are mainly structural elements and are commonly found in traditional Bhutanese architecture. The following elements are categorized under Main Architectural Elements in this Guidelines:</p>	<p>Secondary Architectural Elements are those that are usually installed to enhance aesthetics and create higher standards of hierarchy and value in traditional Bhutanese architecture. The following elements are included under this category:</p>	
<ol style="list-style-type: none"> 1. Kachen (column) 2. Zhu (capital) 3. Jadhang Tazi 4. Payab Gochu (windows) 5. Mago (doors) 6. Rabsel 7. Chimtog (Roof) 	<ol style="list-style-type: none"> 1) Bogh 2) Phana 3) Pem 4) Choetse 5) Tshechu Kha-Nyim 6) Norbu Bagum 7) Norbu Horzhu 	<ol style="list-style-type: none"> 8) Gyetsa 9) Keymar 10) Nyim Khep 11) Sertog 12) Gyeltshen 13) Lhadhar 14) Mythical Animal Sculptures



MAIN ARCHITECTURAL ELEMENTS

1. KACHEN (COLUMN)
2. ZHU (CAPITAL)
3. JADHANG TAZI
4. PAYAB GOCHU
(WINDOWS)
5. MAGO (DOORS)
6. RABSEL
7. ROOF

KACHEN AND ZHU

Kachen and Zhu are the traditional Bhutanese column and capital that are built together as a component. In traditional Bhutanese architecture, the Kachen and Zhu are fashioned out of timber by local carpenters as two separate elements and then assembled together during installation in a building. The more elaborate Kachen and Zhu were normally installed in Dzongs, Lhakhangs and palaces. They are also installed in the main altar room of family homes. Simple style Kachen (also called kawa when in simple post form) are usually found mainly in farmhouses.



Gantey Goenpa Kachen & Zhu
(Picture: Dorji Yangki)

KACHEN AT TRASHICHODZONG

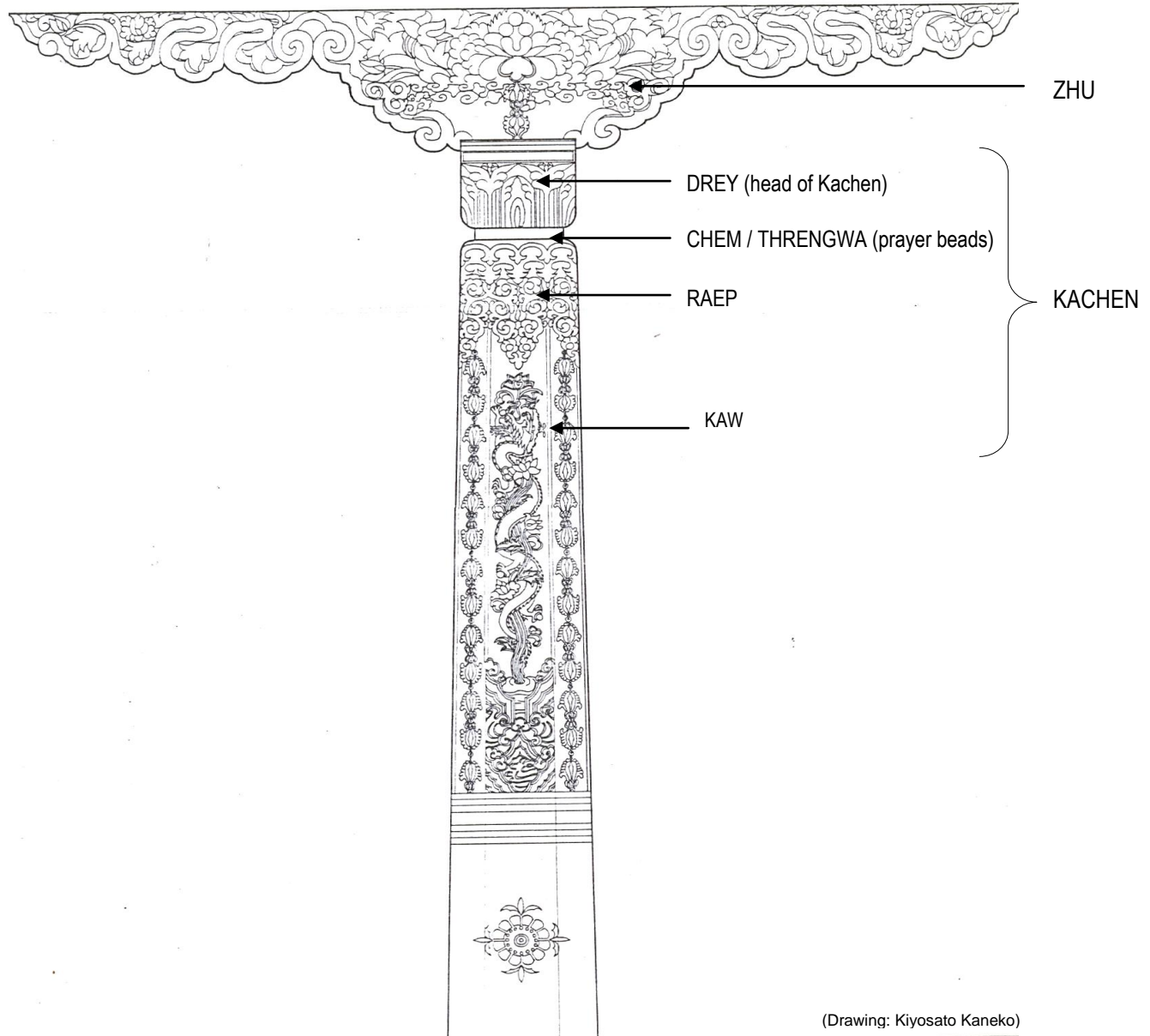

(Drawing: Kiyosato Kaneko)

TYPICAL KACHEN AND ZHU DETAILS

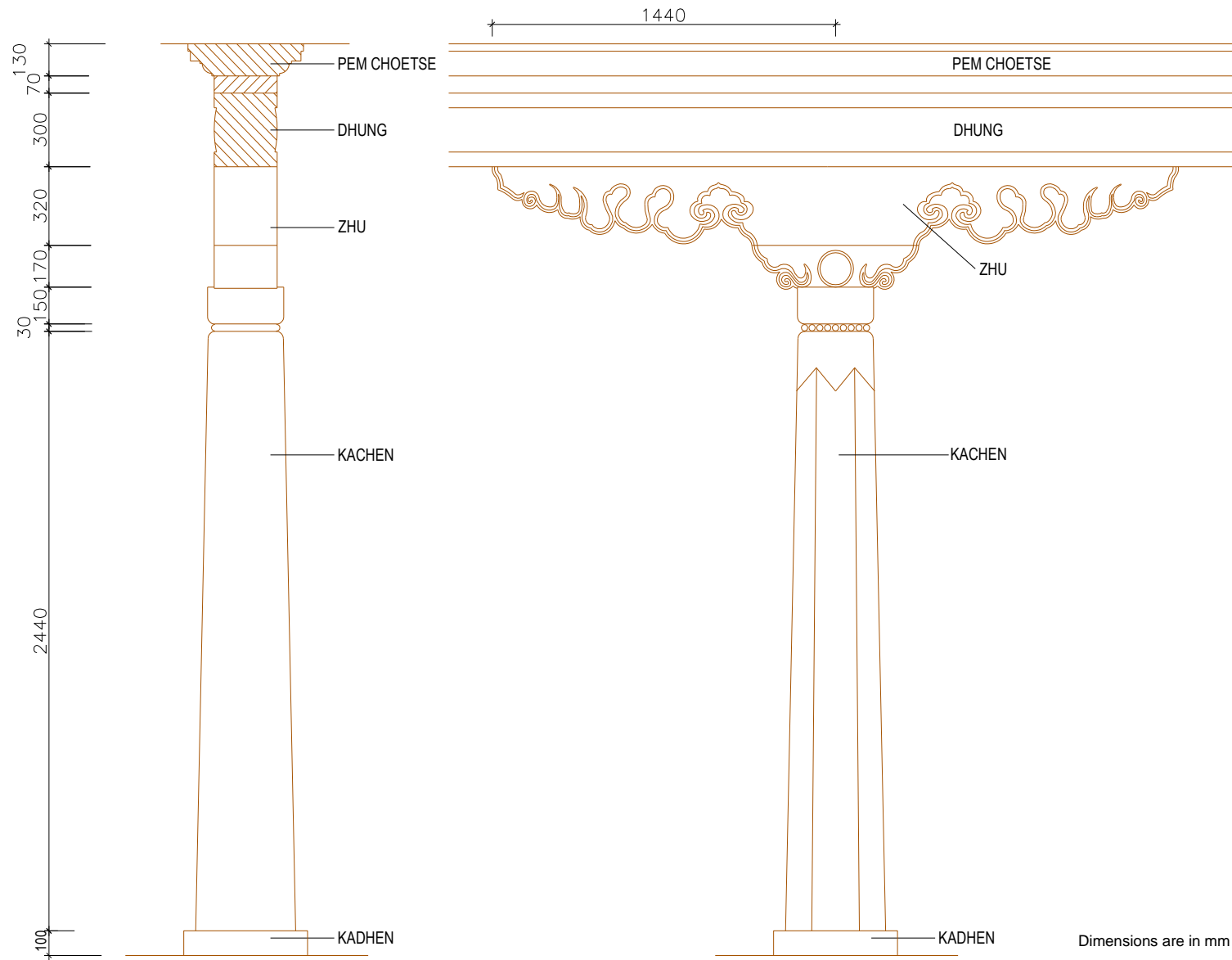

Dimensions are in mm
(Drawing: Dorji Yangki)

KACHEN

A column or post is known as “*Ka*” while “*Chen*” means large in Dzongkha. Therefore, a Kachen literally means large column.

In Bhutan, the Kachen were more commonly installed in Dzongs, Monasteries and royal palaces thus helping to signify their important status in the community. Kachen were rarely found in ordinary homes or residential buildings in the past. However, Kachen are now used more commonly also in residential buildings.

Although a Kachen can be designed with many different corners and sides, the four main shapes of Kachen found commonly in Bhutan include the following:

1. Square shaped Kachen
2. 12 corner Kachen
3. Circular shaped Kachen
4. Octagonal shaped Kachen

A Kachen is normally fashioned out of timber with a distinct tapering body (*Kaw*), shoulder (*Raep*) and head (*Drey*) that are separated with a neck of carved beads known as *Chem* or *Threngwa*. The timber Kachen was normally placed on a circular or square base known as *Kadhen* made of single slab of stone especially when part of the external corridor.



SQUARE –SHAPED KACHEN

A Square shaped Kachen is one of the most basic Kachens. It has a square shaped body, shoulder and head with four equal sides.



Punakha Dzong Square Kachens

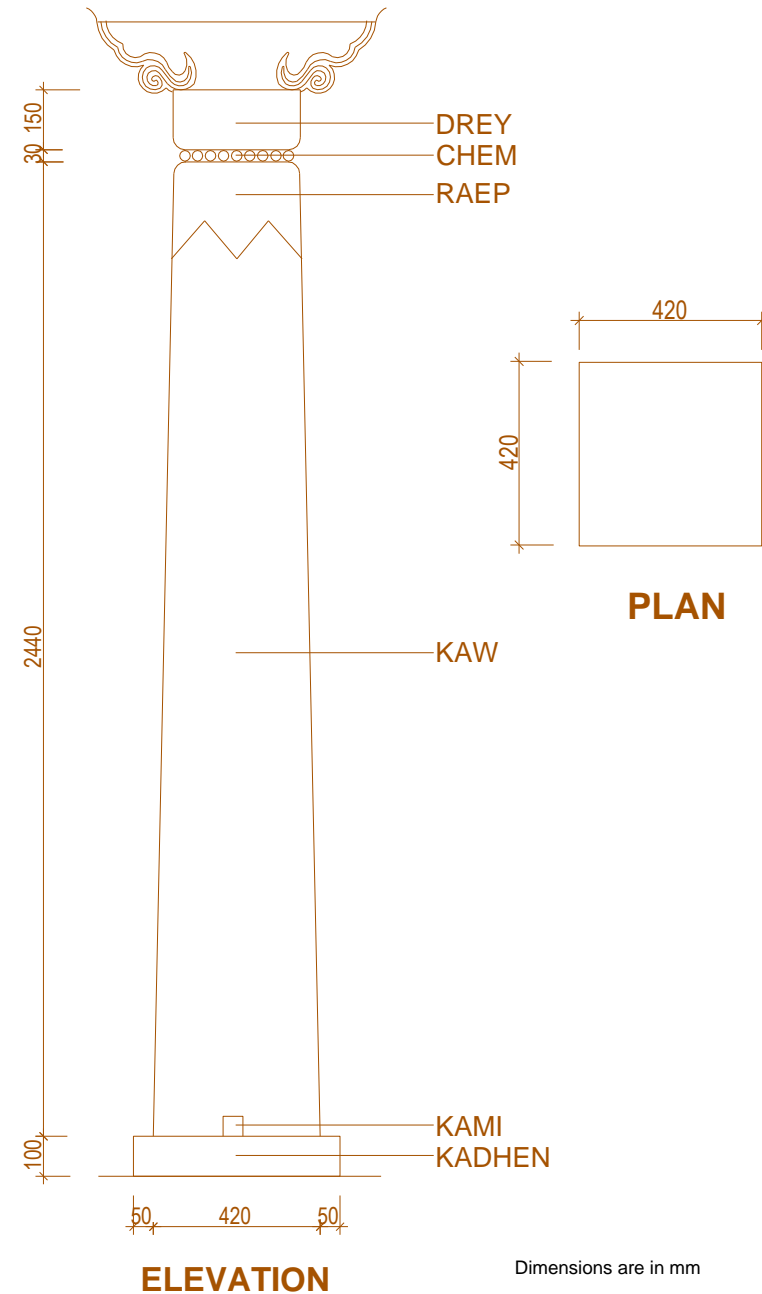

12 CORNER KACHEN

A 12 Corner Kachen is one of the most complicated Kachens. It has a body, shoulder and head with 12 corners and 20 sides.

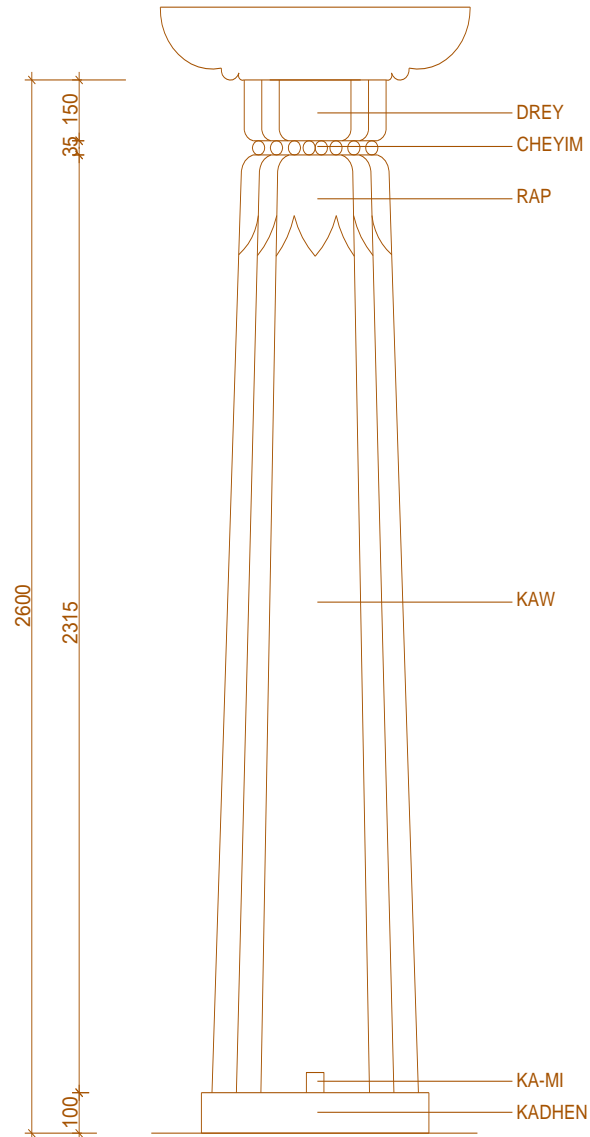
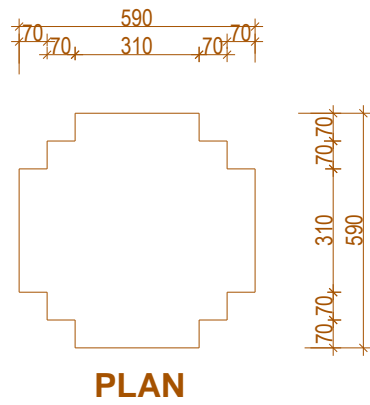

Kachen at the Entrance of Gantey Goenpa

Dimensions are in mm
(Picture & Drawing: Dorji Yangki)

CIRCULAR-SHAPED KACHEN

A circular shaped Kachen is rare in Bhutanese architecture as they are harder to fashion than square shaped Kachens.

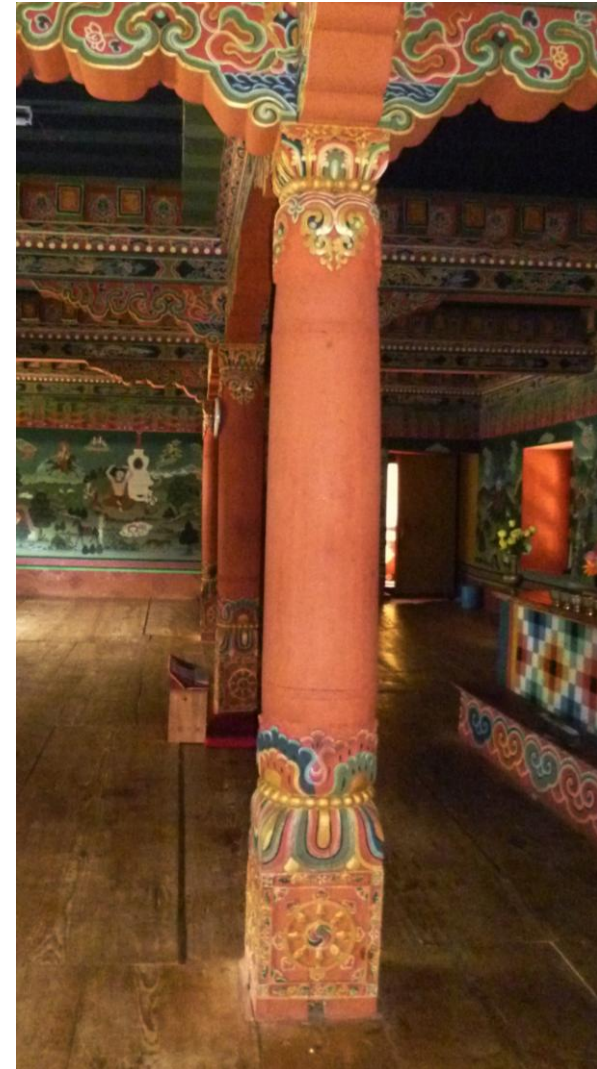
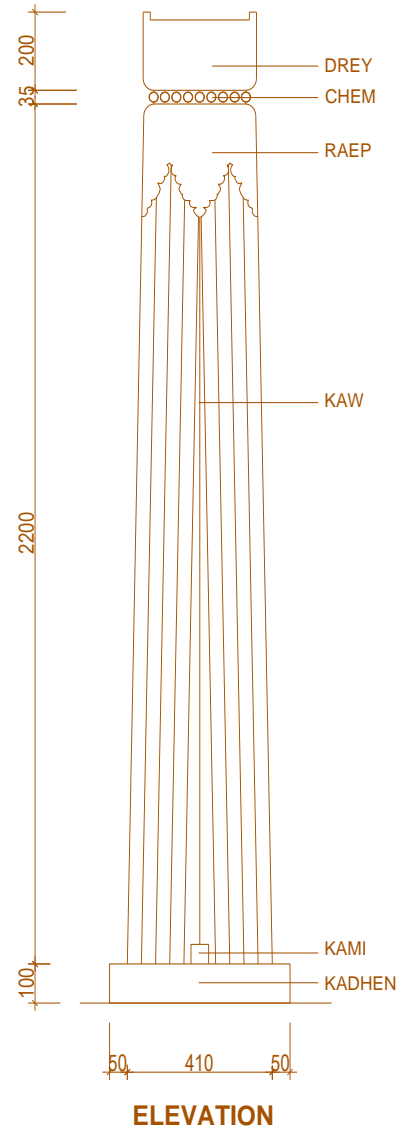
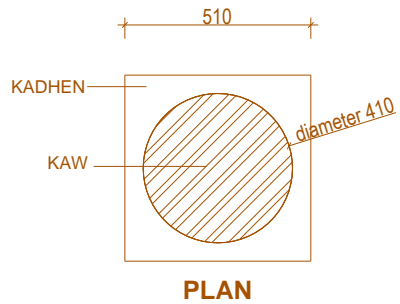

Circular shaped Kachens at Semtokha Dzong

Dimensions are in mm

(Drawing & Picture: Dorji Yanki)

OCTAGONAL –SHAPED KACHEN

An Octagonal shaped Kachen is the next common type of Kachen after the Square shaped Kachen.

It has eight levels of sides with the levels shaped in a slightly concave manner.

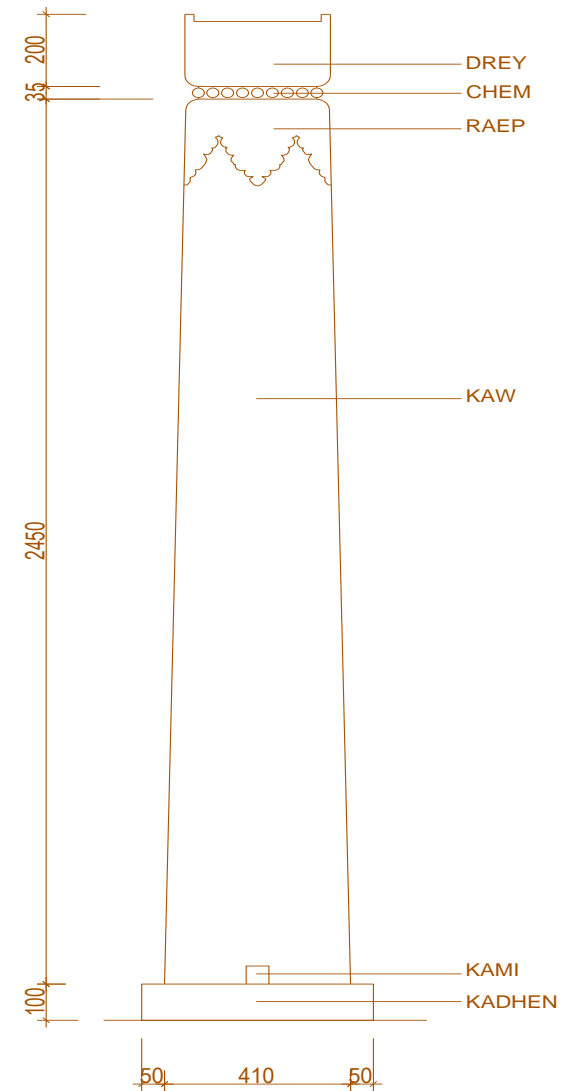

ELEVATION

Octagonal shaped Kachens
(Drawing & Picture: Dorji Yangki)

ZHU

One of the most diverse elements in the traditional architecture features, Zhu is a bow shaped timber bracket placed as a capital on top of the Kachen.

As a bracket, the Zhu served a structural function to support the load from the Dhung (beam) above.

There are no strict rules as to the type of Zhu one can use on a particular structure. This depends entirely on the elaborateness of the adjacent architectural elements. However, care is taken to ensure that the shape and proportions of a Zhu are maintained in proportion to Kachen.

The Zhu in Bhutanese traditional architecture is usually categorised according to level of intricacy of carvings and paintings on the Zhu.

The three main different categories are the following:

1. Gyalp Dhen Zhu
2. Zhu Jaam Tshab
3. Langna Drey Zhu



The typical Zhu has carvings that relate to hierarchy and harmony of people, animals and nature. The carvings represent the following:

- A King presiding on royal throne
- A Queen bowing in graceful obeisance to the King
- A dutiful Minister in attendance to the command of the King
- Twin elephants climbing up the mountain
- A snake entering its hideaway hole
- Water flowing in abundance down from the mountains

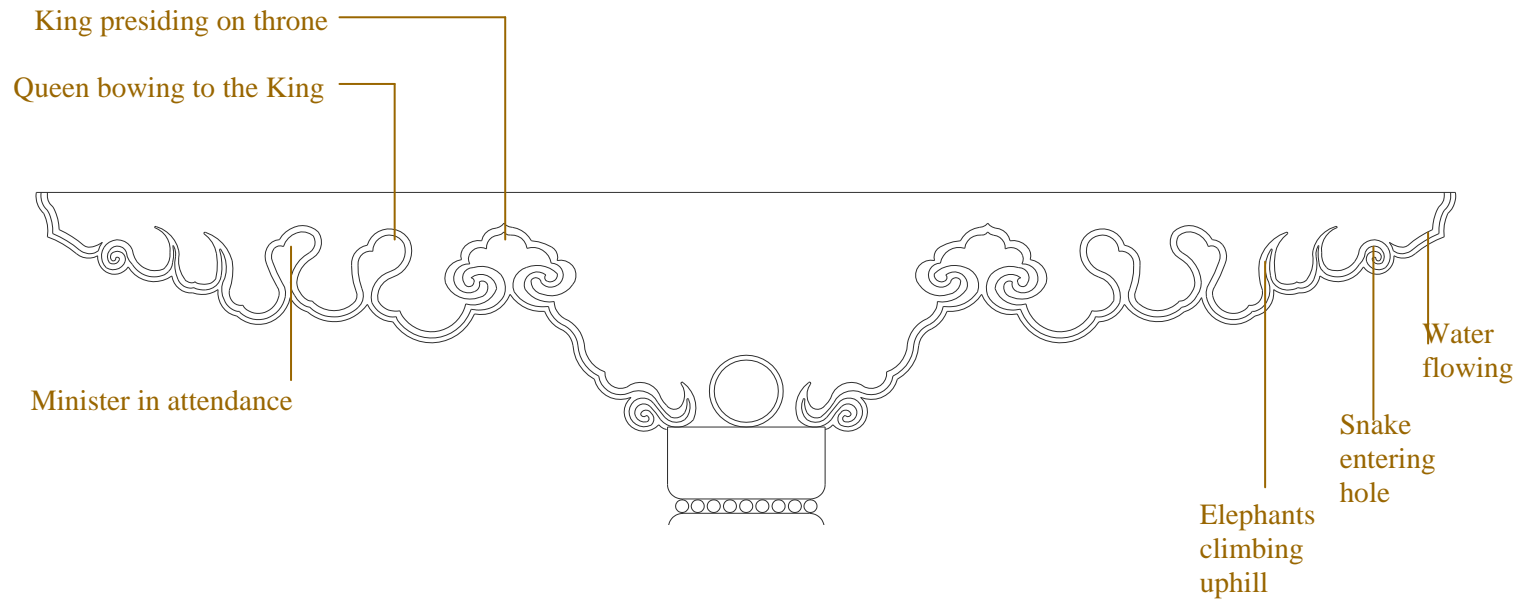

(Drawing: Dorji Yangki)

GYALP DHEN ZHU

The Gyalp Dhen Zhu is the most intricate type of Zhu and this type of Zhu were normally installed in important buildings such as Dzong, Lhakhang, and palaces. In the past, such intricate Zhu were the “Thobthang” (entitlement) of aristocratic families or religious buildings.



Zhu at Punakha Dzong
(Picture: Namgye Retty)

EXAMPLES OF GYALP DHEN ZHU



Trongsa Dzong Zhu
(Picture: Namgye Retty)



Ugyen Pelri Palace Zhu
(Picture: Dorji Yangki)



Gantey Goenpa Zhu
(Picture: Dorji Yangki)



Khotakha Lhakhang
(Picture: Dorji Yangki)

ZHU JAAM TSHAB

The Zhu Jaam Tshab is a simple type of Zhu without intricate carvings or paintings. This simple Zhu was installed in buildings of less standing such as farmhouses. This type of simple Zhu can also be found in rooms of less importance in Dzongs, Lhakhangs and palaces such as in storage rooms, and staff residential areas.

This type of simple yet elegant Zhu are also found used on the Ground Floor level of Dzongs and Drasha (residential area for monks) of Lhakhangs.



Zhu Jaam Tsab at Wangdue Dzong
(Picture: Dorji Yangki)

Zhu Jaam Tsab at Paro Dzong
(Picture: Dorji Yangki)

LANGNA DREY ZHU

The Langna Drey Zhu is the only type of Zhu that is not placed as a capital on a Kachen.

It is located under protruding Rabsel balconies and bay windows.



Langna Drey Zhu under
Rabsel at Gantey Goenpa
(Picture: Dorji Yangki)



EXAMPLES OF DREY ZHU



Langna Drey Zhu under Rabsel at Lhuntse Dzong, Kurje Lhakhang, Wangduecholing Dzong and Changjiji house
(Picture: Lhuntse Dzong Namgay Retty; Other Pictures: Dorji Yangki)



**Drey Zhu at Dema
Lhakhang, Pangrizampa**

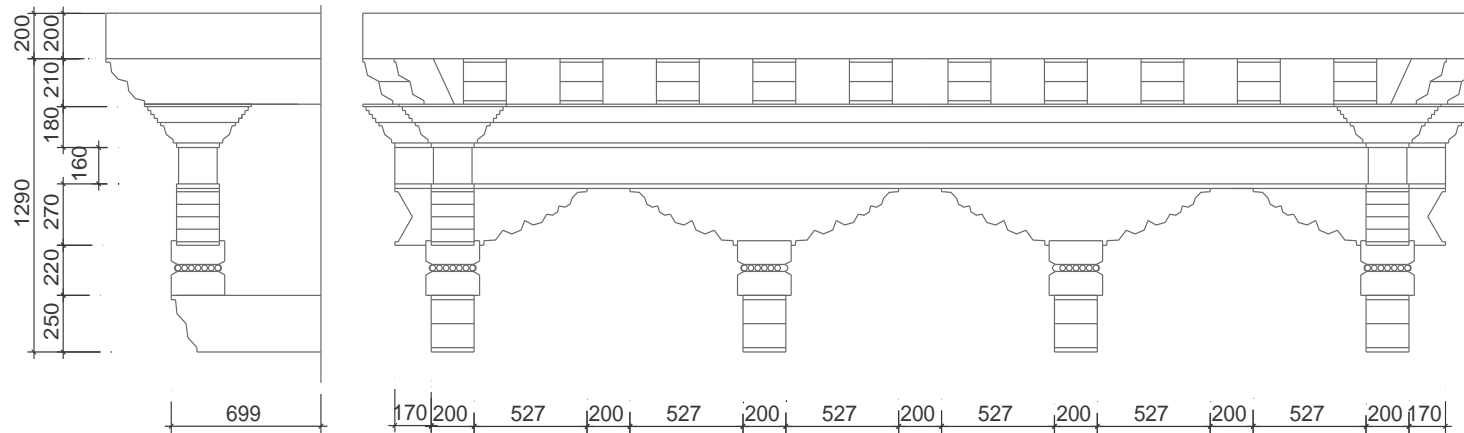

Drey Zhu Details

Dimensions are in mm
(Drawing: Dorji Yangki)

JADHANG TAZI

Jadhang Tazi is the name commonly used for traditional balcony railings. Landing railings, roof barrier railings and stair hand railing balusters are as well often called Jadhang Tazi too. Tazi is sometimes also pronounced Tazee in some areas of Bhutan.

The name Ja-dhang Ta-zi is derived from the functions of a balcony with railing. “*Ja*” literally means bird, while “*dhang*” is from the name given to a timber perch (for the bird to rest on).

The name “*Ta*” originates from the action to look down from the balcony while “*zi*” is an honorific reference of the same action to look or observe.



Jadhang Tazi at the main entrance of Semtokha Dzong in Thimphu
(Picture: Dorji Yangki)

The design for Jadhang Tazi can be very simple or very elaborate with *Tshegen*, intricate carvings and paintings.

The width of the newel post of Jadhang Tazi is traditionally said to be of the size of a palm width and is usually square in dimensions.

The height of the newel is said to be of standard human height or just below the shoulders. The cap on the newel post is designed as an offering of “Norbu tog” (wish granting treasure).



Details of Jadhang Tazi

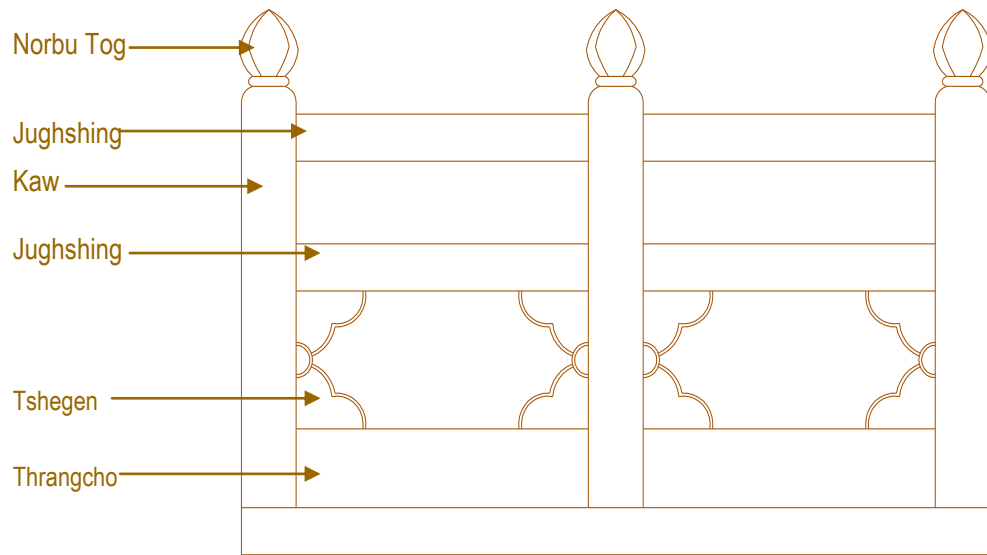

ELEVATION

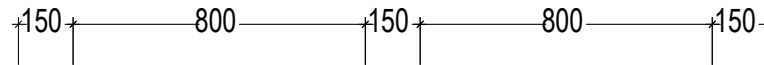

PLAN

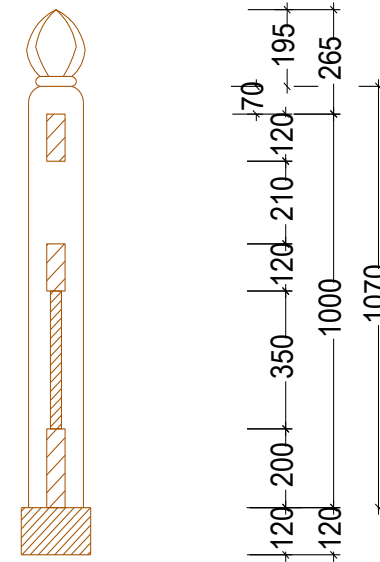

SECTION

**DRAWING DETAILS OF
A TYPICAL TRADITIONAL
JADHANG TAZI MADE IN TIMBER**

Dimensions are in mm

(Drawing: Dorji Yangki)



Some examples of different places where Jadhang Tazi are commonly found:

- Attic,
- Corridors,
- Balconies,
- Stair landing

Above Left: Tashigang Dzong
Above right: Paro Dzong
Left: Wangduecholing Dzong

(Pictures: Dorji Yangki)



Jadhang Tazi without Tshegen

This type of simple yet elegant style is usually found in older Dzongs, Lhakhangs and in farmhouses.

Above: Wangdue Dzong,
Left: Semtokha Dzong

(Pictures: Dorji Yangki)

PAYAB GOCHU

The Payab Gochu, which is a traditional Bhutanese window that is embedded within the facade walls of a building, is an important element of traditional Bhutanese architecture.

There are many different styles of Payab. The 3 main types of distinctive Payab Gochu in ancient traditional Bhutanese architecture are:

1. Horgo Payab,
2. Lingo Payab,
3. Gedkar Payab,

The 4th style of Payab, which has been in use only for the past 70 years in Bhutanese architecture, is known as Boego Payab.

The Payab Gochu windows are in general simple when compared to the design of the Rabsel. However, in important buildings (such as Dzong or Lhakhang) they are designed with elaborate carvings, multiple layers of traditional cornices, lintels and intricate paintings.

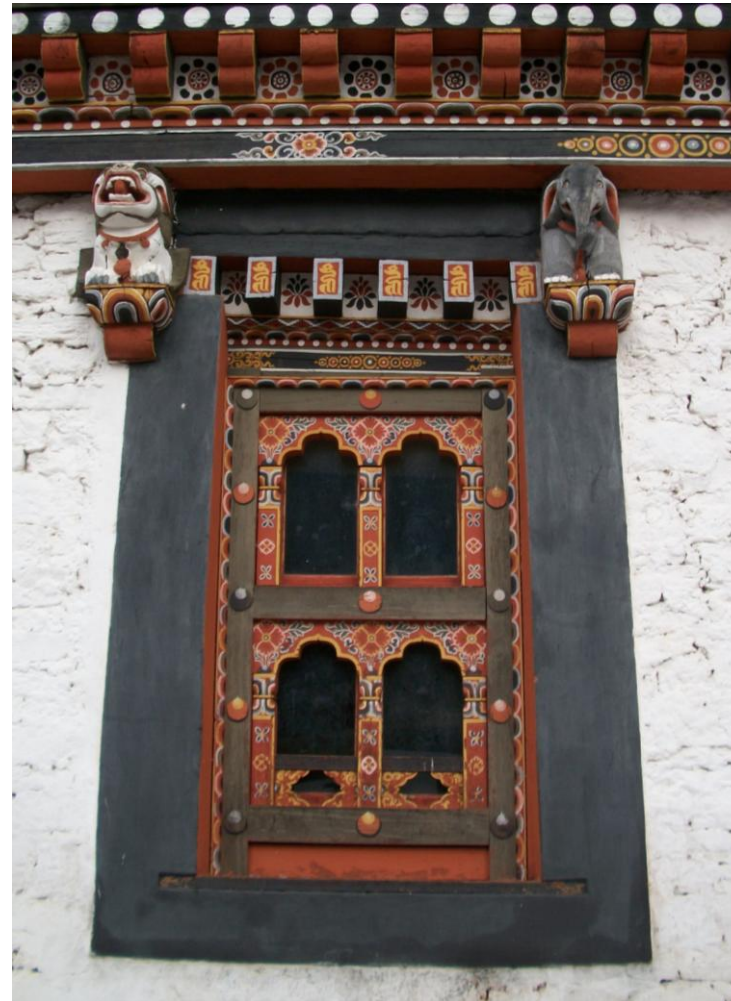

Payab at Trashichodzong, Thimphu
(Picture: Dorji Yangki)

Traditionally, the Payab Gochu is flanked and shored on all sides with timber boards. The two sides are flanked with timber boards called Loshog that protect the window to the walls. The lower level is shored with the traditional timber sill called Chiden. The upper part of the Payab has the lintel called Zangshing.

The general practice in traditional Bhutanese architecture is to incorporate one layer of Bogh (cornices) above the Payab Gochu. The layer of Bogh can be single or double and is sometimes also constructed with a single layer of Phana over the layer of Bogh depending on the significance of the building or the budget available.

The layer of Bogh is always supported by a layer of Pem and Choetse and with Dhung or Zumchu. The layer of Choetse is placed above the layer of Pem.

These are then placed above the timber members Dhung or Zumchu. When Dhung is omitted, the Zumchu sits directly on the timber window framework called Yathoe.

PAYAB GOCHU DETAILS

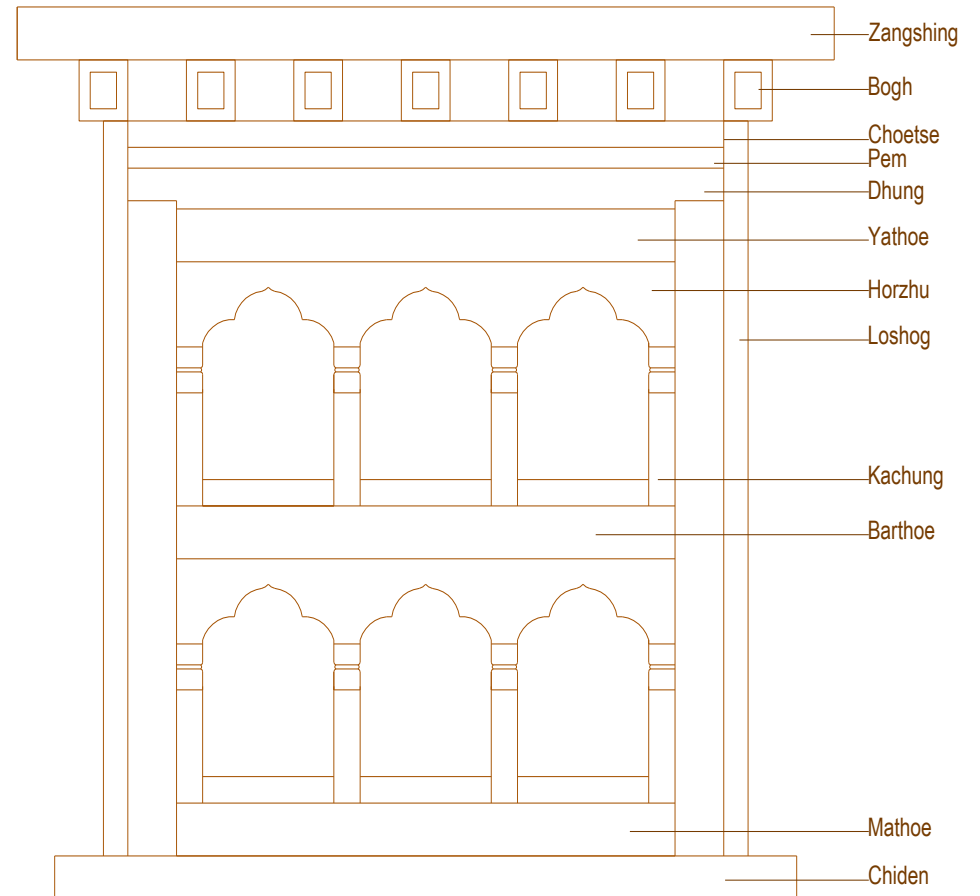

(Picture & Drawing: Dorji Yangki)

HORGO PAYAB

The Horgo Payab is double tiered window with each window opening framed at the top level of its timber frames with Horzhu or Zing carvings as shown in the picture.

The traditional Horgo Payab is usually flanked on the two sides by square or rectangular timber panel frames known as Shamig or Soma. This was

in order to allow for timber shutters of the windows to slide open behind the Shamig or Soma. However if the sliding window shutters were replaced with hinged shutters it was designed without the Shamig.

The Horgo Payab is usually designed with one or two layers of Bogh with Pem, Choetse and Dhung. It normally

did not have a layer of Phana as the Horgo Payab was usually placed on the lower level floors of a building. However when it is placed on the top floor it is also constructed with a layer of Phana. The Horgo Payab was traditionally designed either with a Thrangcho at the lower level of the window or it was left simple without a Thrangcho.



Horgo Payab at
Semtokha Dzong

HORGO PAYAB WITH SHAMIG

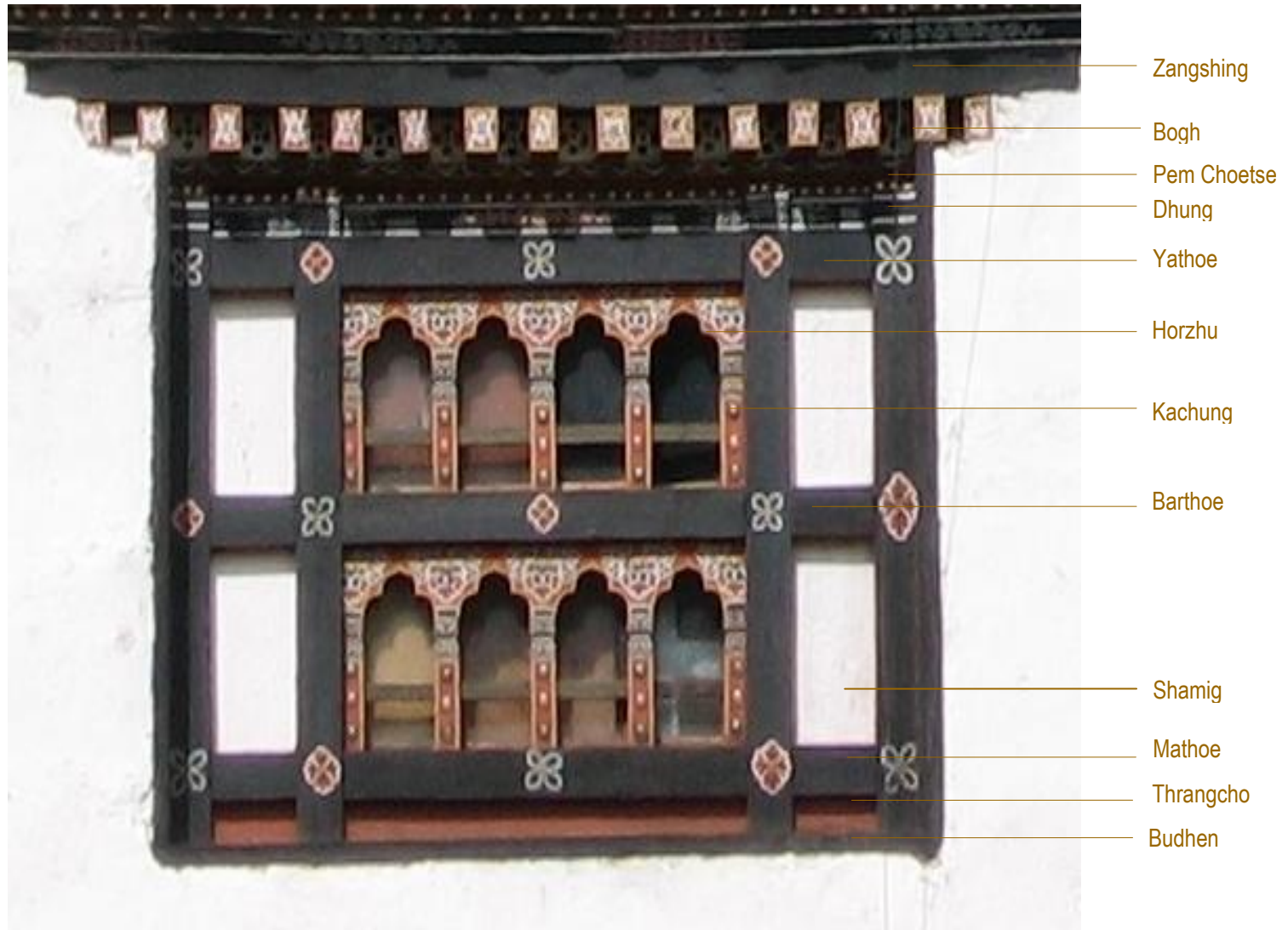

HORGOPAYAB DRAWING DETAILS

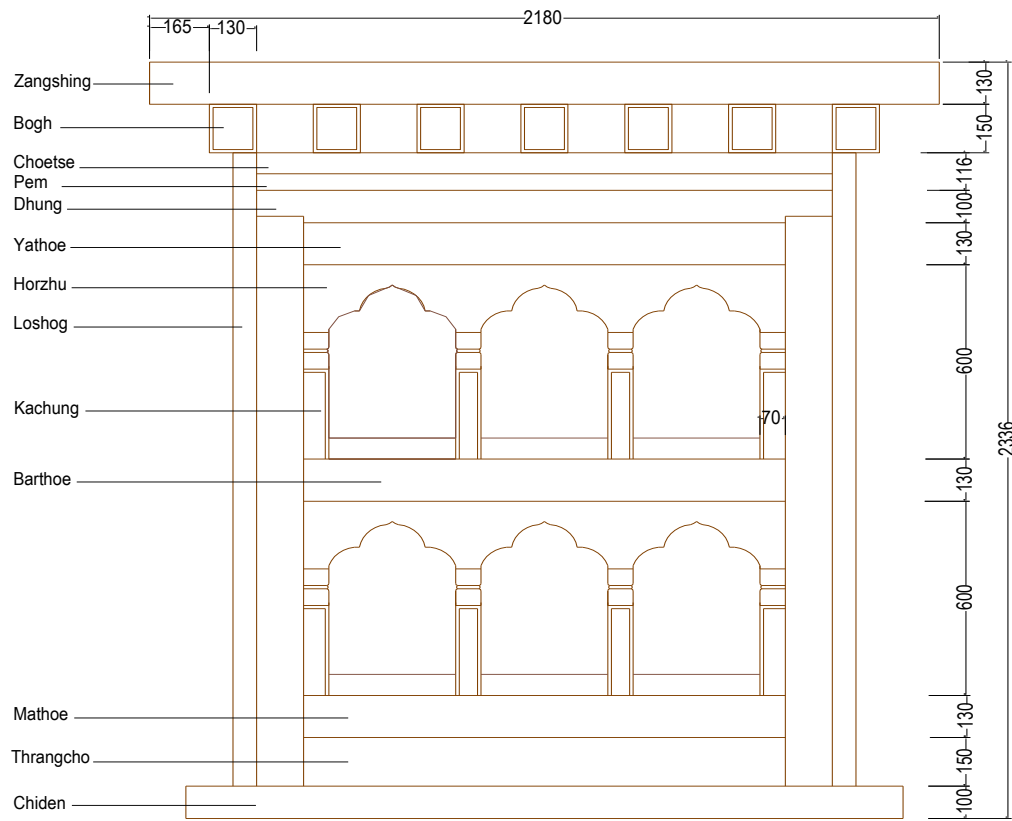

ELEVATION

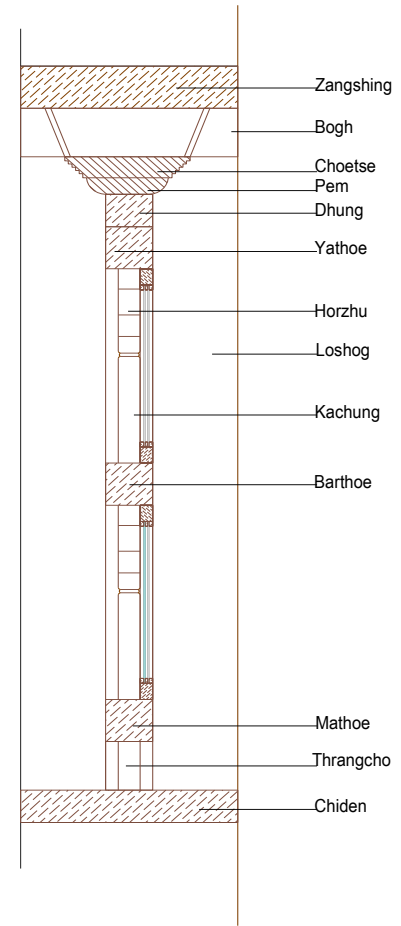

SECTION

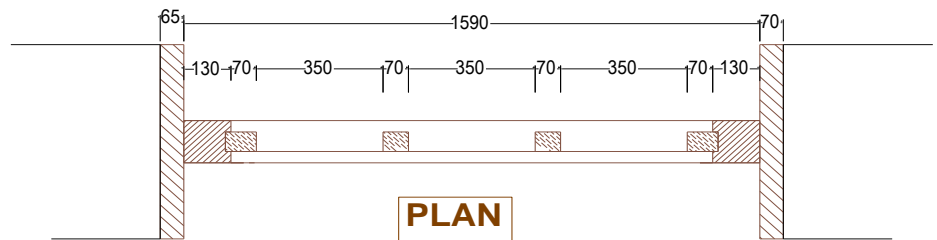

PLAN

Dimensions are in mm

(Drawing: Dorji Yanaki)



Horgo Payab at Trashichodzong and Tango Goenpa

(Pictures: Choening Dorji & Dorji Yangki)

LINGO PAYAB

The Lingo Payab is a traditional window that is usually installed in rooms that did not need a lot of light in the Dzongs, Lhakhangs and Palaces.

The Lingo Payab with elongated heights was also used when there was a need to let in natural light while at the same time taking care of the need for provision of spaces on the walls for large paintings and murals inside a temple.

The name Lingo is said to originate from a place called Ling in Tibet where these windows were used in abundance.

Although the Lingo and Gedkar Payabs seem similar in design, the openings in Lingo Payab are much wider than in the Gedkar Payab.

The Lingo Payab is also sometimes designed with a timber panel called Thrangcho at the base and has multiple Jughshing or Timber rails in between the frames to cut the openings into smaller openings.

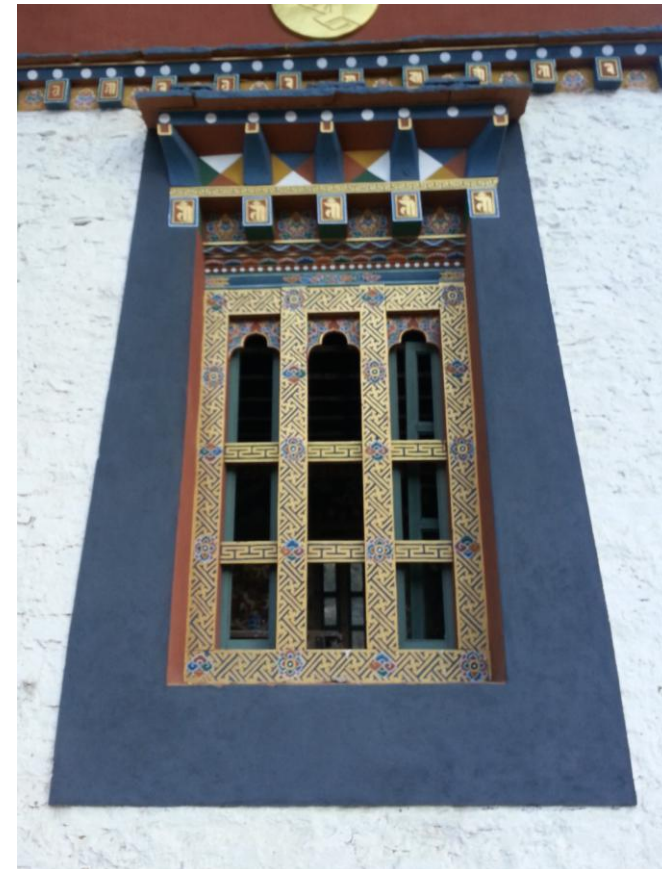

Lingo Payab at Pangrizampa, Thimphu
(Picture: Dorji Yangki)

While the Gedkar Payab was often left without shutters the Lingo Payab was always designed with interior timber shutters made from timber panels that were hinged on timber pivots at the top and bottom frames.

The Lingo Payab is always installed with Bogh, Pem Choetse, and Thrangcho.

It is usually designed without any Horzhu carvings and thus sometimes kept simple in design.

If Horzhu is added to the Lingo and the openings are kept as wide as a door, then traditionally, the window then becomes a Geysargo door.



Lingo Payab at Domkhar

(Pic: DCHS, Dept of Culture)

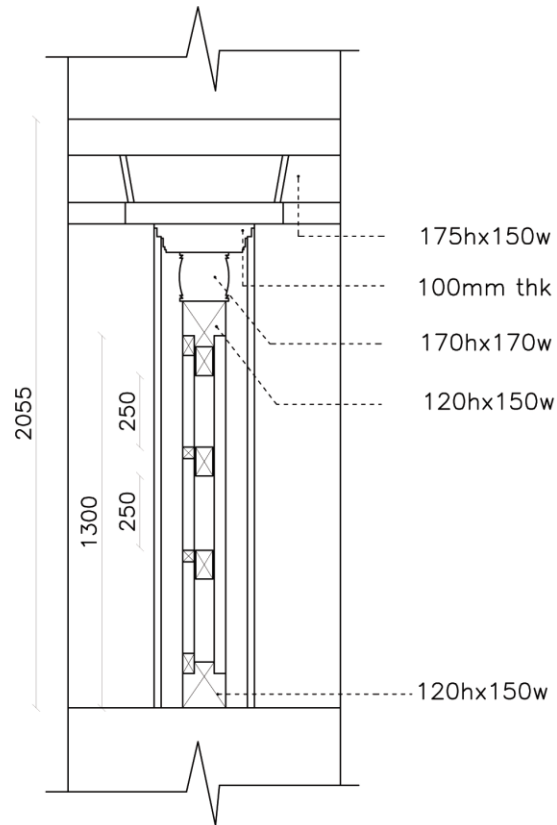

SECTION A – A

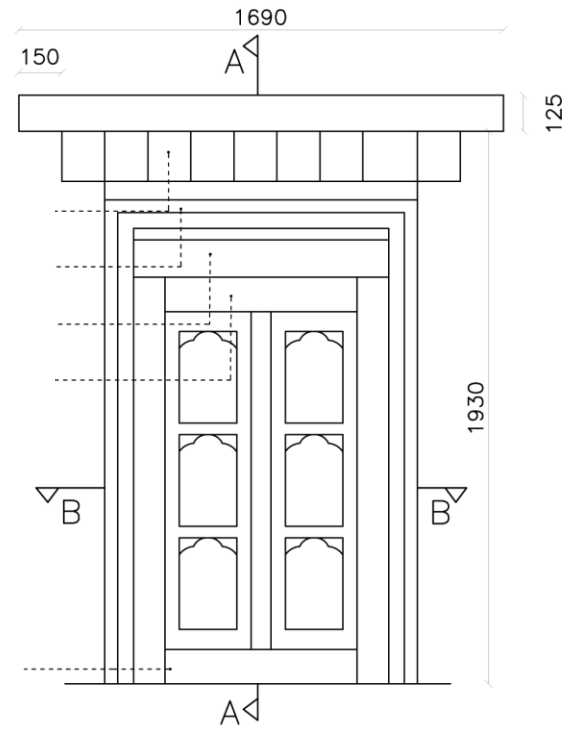

- 175hx150w Bogh
- 100mm thk Pem Choetse
- 170hx170w Dhung
- 120hx150w Yathoe
- 120hx150w Mathoe

LINGO PAYAB DRAWING DETAILS

Dimensions are in mm

(Drawing: DCHS, Dept of Culture)

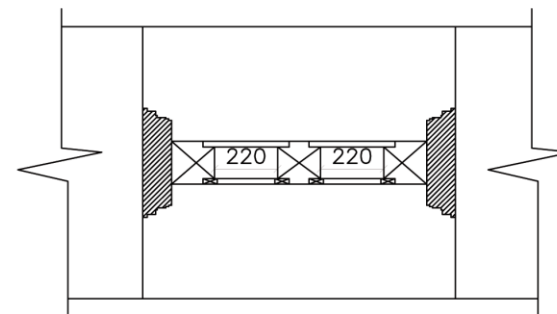

SECTION B – B

GEDKAR PAYAB

The Gedkar Payab is the window with the most basic design in traditional Bhutanese architecture. It usually has a small narrow opening and was placed in less important rooms such as storerooms, spaces for animal shelter, basements, and passages on the ground floor.

The Gedkar Payab is made up of a simple plain rectangular timber frame and it usually does not have any Bogh (cornices) or Pem Choetse carvings or paintings. The topmost lintel called Zangshing is thus placed directly on the window upper frame called Yathoe. However, in buildings such as Dzongs and Lhakhangs where the walls were very thick, the Gedkar is sometimes designed with a Zimchu or Dhung between the Yathoe and Zangshing lintel to provide extra support to the walls above.



Gedkar Payab at Wangduecholing Palace

(Picture: Dorji Yangki)

The openings for light in a Gedkar Payab are generally very narrow ranging from 100mm to 250 mm in opening width.

The Gedkar Payab found in farmhouses are much smaller and are designed with a series of horizontal members that divide the elongated narrow openings into smaller divisions.

This was usually to provide protection from intruders as the Gedkar were usually placed on the Ground Floors of buildings.

Since the Gedkar were usually in spaces that were rarely inhabited by people, they were left open without any timber shutters.

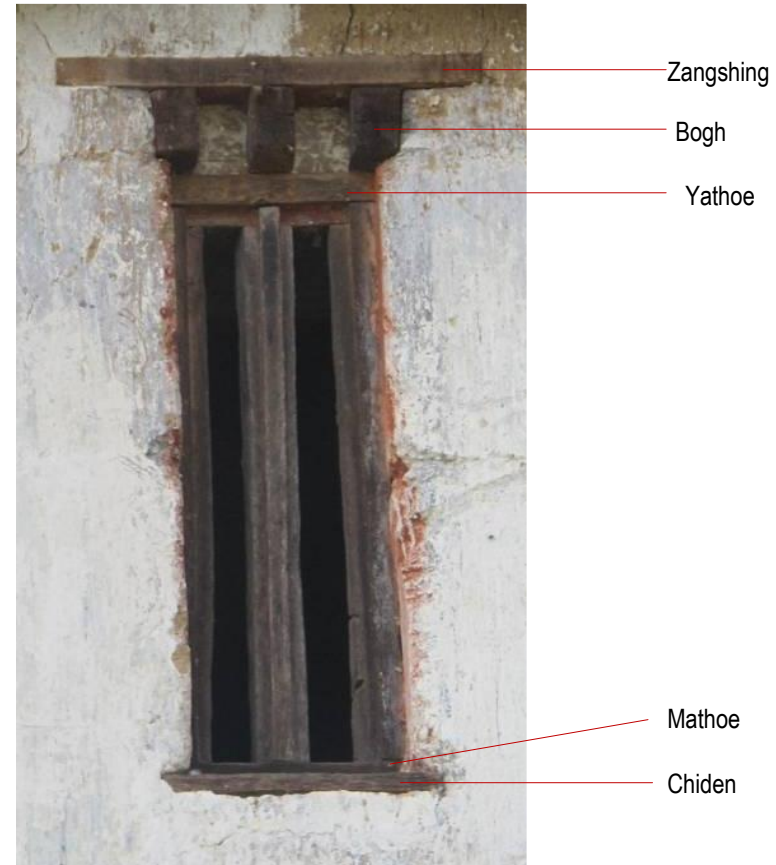

Gedkar Payab at Chegana Lhakhang
(Picture: Yeshey Samdrup)

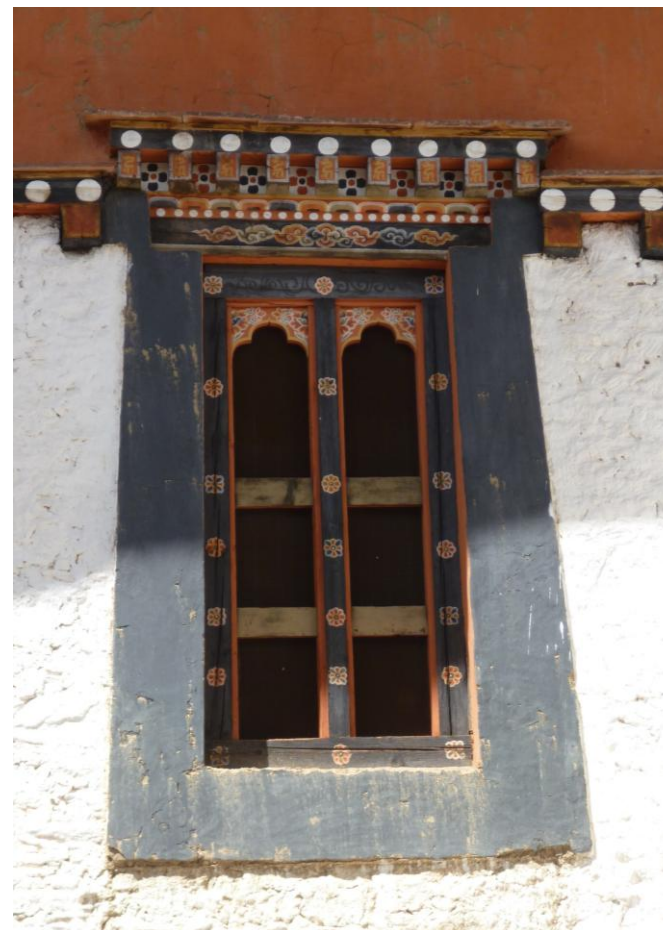

Gedkar Payab at Gantey Goenpa and Semtokha Dzong
(Picture: Dorji Yangki)

BOEGO PAYAB

The Boego Payab is a Bhutanese window that has been developed in the past 70 years since the introduction of glazing into traditional Bhutanese architecture.

It is used in not only family homes and apartment buildings but also recent Dzong and Lhakhang architecture.

The Boego Payab is an interpretation version of the Horgo Payab where the two tiers of openings are reduced to just one level of opening. The Barthoe is thus removed.

However, apart from the reduction of two tiers to one tier, all other Payab elements found in the Horgo Payab are also found in the Boego Payab.

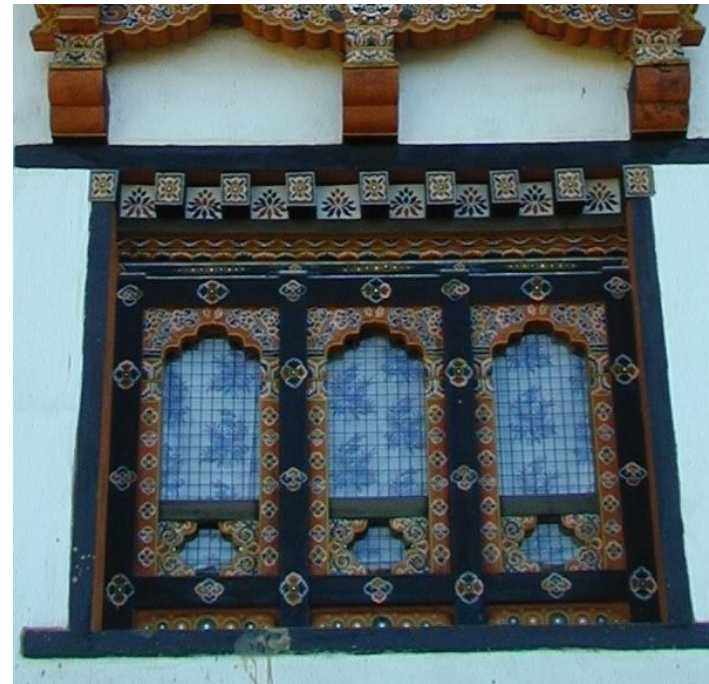



- Zangshing/Salen
- Booh
- Pem Choetse
- Dhung
- Yathoe
- Horzhu
- Kachung
- Loshog
- Mathoe
- Chiden

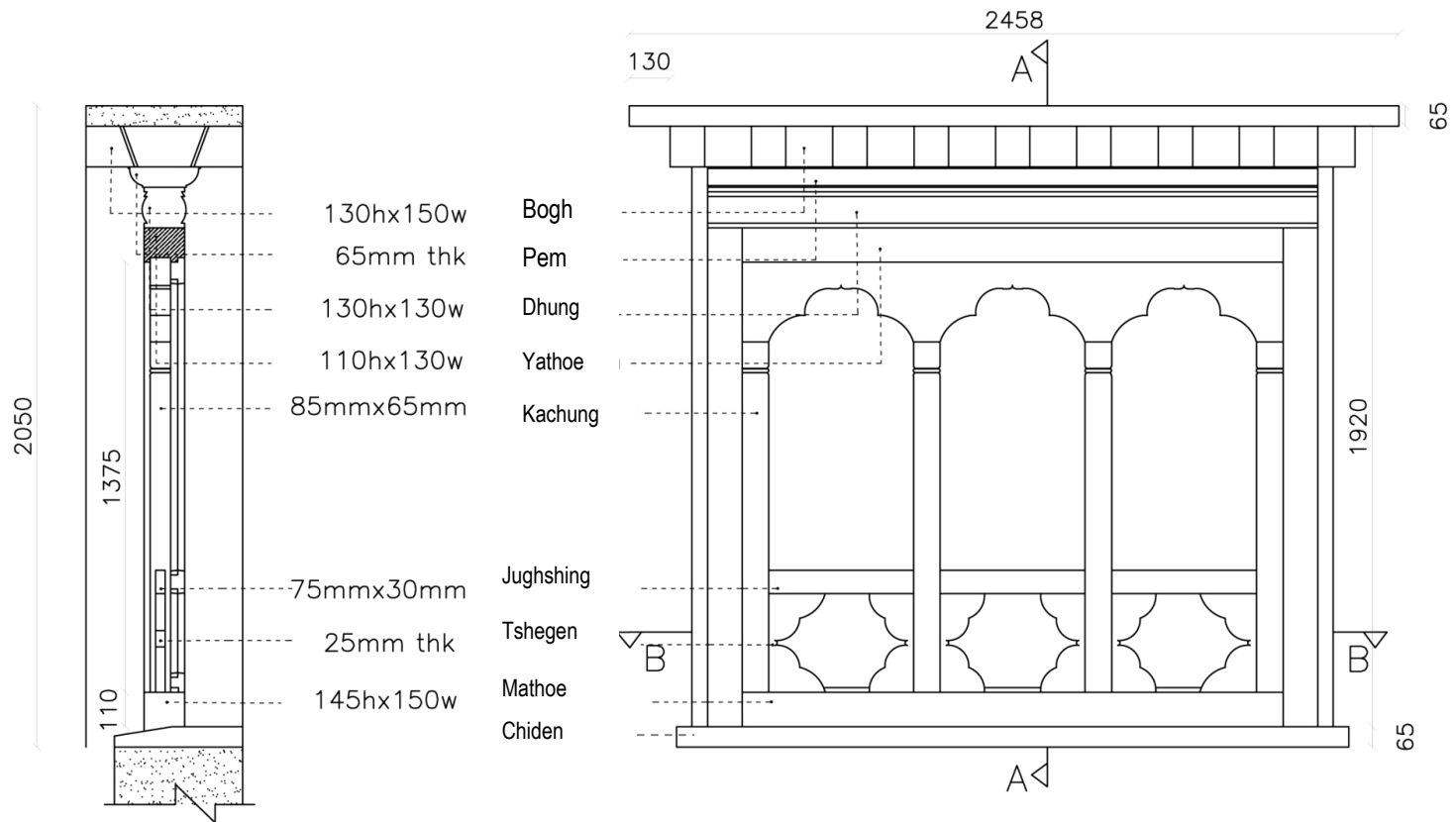

SECTION A – A

BOEGO PAYAB DETAILS

Dimensions are in mm

(Drawing: DCHS, Dept of Culture)

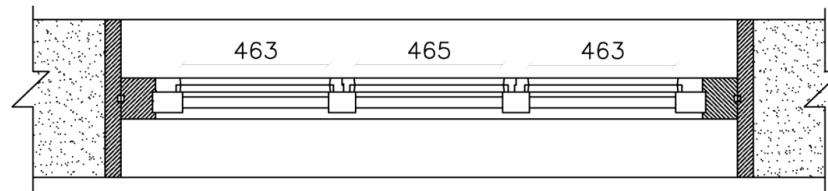

SECTION B – B

MAGO (DOORS)

Mago or the main entrance door to a traditional Bhutanese house is an important aspect of a building.

The direction of the door is usually dictated by various Buddhist astrological instructions in relation to the function of the building and the date of birth of the owners of the building.

For good fortune and prosperity, in the case of a family house, the local belief is that the outer door should face a direction according to the man's date of birth and the direction of an internal door should be installed according to the date of birth of the woman.

The doors of homes are typically simple. However, the Mago in Dzongs, Lhakhangs and palaces are elaborately decorated with intricate carvings on the doorframes. Sculptures of the heads of auspicious animals such as the Singye Karpo (snow lion), Jachung (garuda) and sometimes even small statues of deities are placed above the door or in between the Bogh above the doorframes.



Door at Ugyen Pelri palace, Paro
(Picture: Dorji Yangki)

The size of the Mago usually depends on the building design, size and significance. However, the sizes of the Mago are traditionally usually over 2000 mm in height and around 1000 mm in width.

The Mago door, especially for those in a Dzong or Lhakhang, is installed with Pem, Choetse, Zumchu and Bogh.

The sizes of the Bogh, Pem and Choetse are often matched to the sizes of the windows near the door to create a more harmonious facade or are in proportion to the size of the doorframes.

Great care is taken by local carpenters to ensure that the proportion of timber frames in a traditional door (especially the entrance door) is designed correctly.

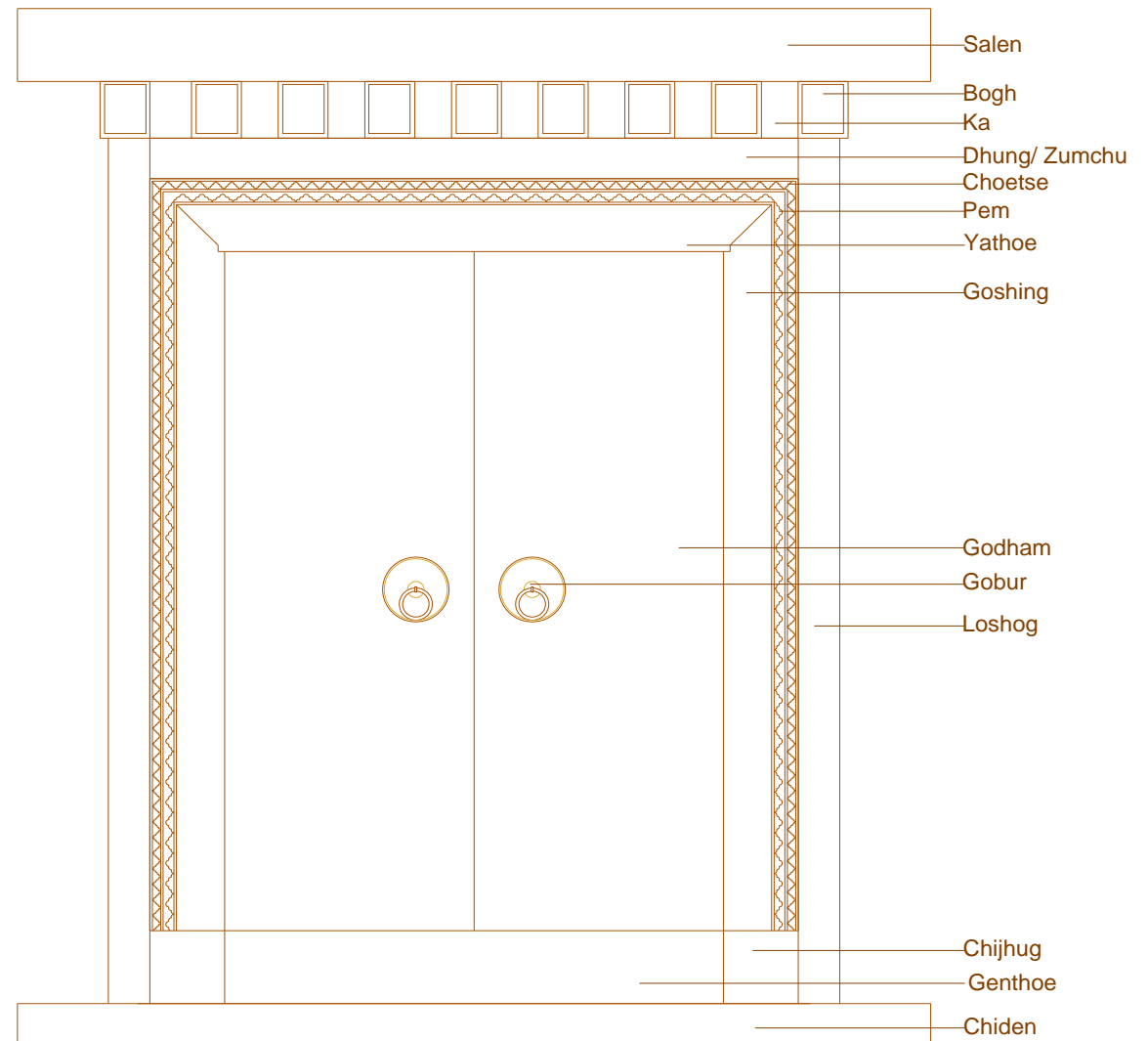

DETAILS OF A MAGO

(Drawing: Dorji Yangki)



Mythical Snow Lion heads carved in timber placed above the main Mago door to a Lhakhang

Door at Lhakhang Sarp,
Trashichodzong, Thimphu
(Pictures: Dorji Yangki)



Semtokha Dzong Entrance Door
(Picture: Dorji Yangki)

TECHNICAL DRAWING DETAILS OF A MAGO DOOR

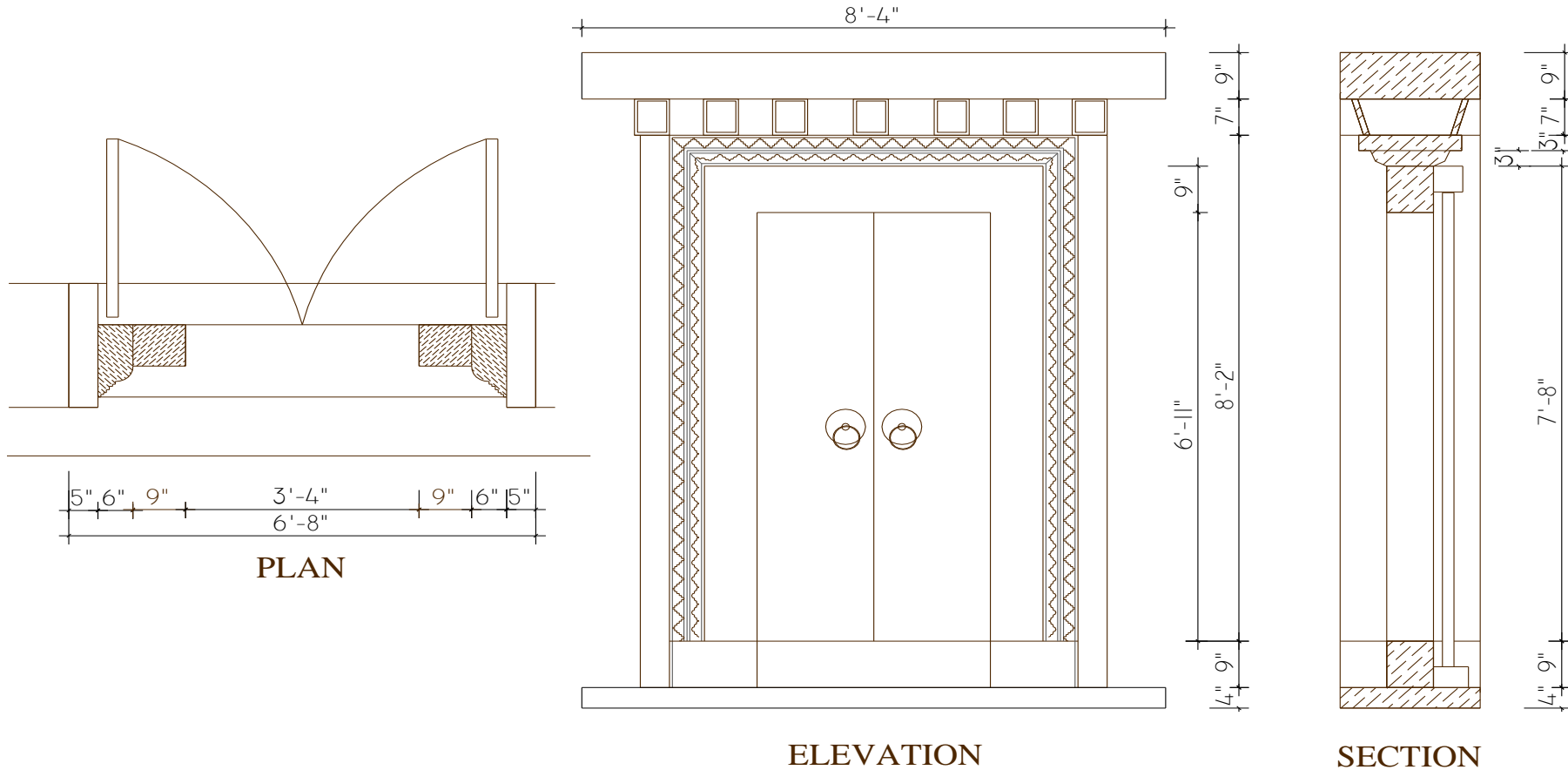

Dimensions are feet and inches

(Drawing: Dorji Yangki)

ROOF

The roof plays an extremely significant part in the characterization of traditional Bhutanese architecture and is therefore one of the most important elements in traditional Bhutanese architecture.

A very noticeable design aspect of the typical Bhutanese roof is the elevation of the roof high above the building (often in layers) to form what is often called the “flying roof”.

This type of roof appears to float above the building. This design thus allowed the roof to protect the building from rain and sun while allowing cooling breezes to flow freely through the attic space under the roof.

This meant that the area under the roof in the attic is thus a very useful and practical space for storing and drying vegetables, fodder and other produce from farms and gardens around a house.

In addition to protecting the building from external environmental elements, in the traditional Bhutanese practice, the roof element additionally played an important role in defining the hierarchy and significance of buildings and their status.



A typical Bhutanese layered “flying roof” in Bumthang
(Picture: Dorji Yangki)



TYPES OF ROOFS IN BHUTANESE ARCHITECTURE

There are four main types of roof design in traditional Bhutanese architecture.

These are the following:

1. Jabzhi Roof
2. Jamthok Roof
3. Drangim Roof
4. Chenkhep Roof

Within the “Thobthang” practice of entitlement of architecture in traditional practice, the Jabzhi roof is the roof of the highest level. The simple gable roof and the layered gable roof style known as Jamthok roof is the most common one found in traditional Bhutanese architecture.

For buildings of very high status such as the Utse of the Dzong, palace or for the Lhakhangs with Sertog the “square hiped” roof called Jabzhi (four corner roof) was used to signify their importance in the community.

ELEMENTS OF THE BHUTANESE ROOF

The roof structure in traditional architecture is constructed with a simple timber frame structure with timber rafters, and purlins supported by columns and brackets. The main roofing cover material used is split timber shingles. The elements of the traditional Bhutanese roof, like other timber frame structures, were also constructed by carpenters without nails or screws.

The principal timber truss rafter plate used for a Bhutanese roof is called a Dhingri. The Dhingri rests on a timber member called Gha which in Bhutanese means saddle. The Dhingri then supports timber posts above which simply saddle over the Dhingri using the weight of the roof to remain in place. The timber central king post is known as Shari while the posts at the sides are known as Shathung. The king post supports a central roof ridge made of timber known as Gungchhen while the Shathung side timber posts support timber under purlins known as Gungchung.

The Gungchhen and Gungchung support the upper rafters known as Tsim. The Tsim are sometimes made of round young tree trunks. Timber battens called Dangchung are laid over the Tsim. Timber shingles called Shinglep were then laid and held in place by stones over the Dangchung. The slope of a roof with Shinglep is kept gentle - between 11 and 13 degrees to prevent the stones from rolling off.

In Bhutanese roofs, the traditional rule of thumb was to space out the rafters so that there is enough space for a man to get through while the purlins are spaced out with enough space for a sparrow to get through.

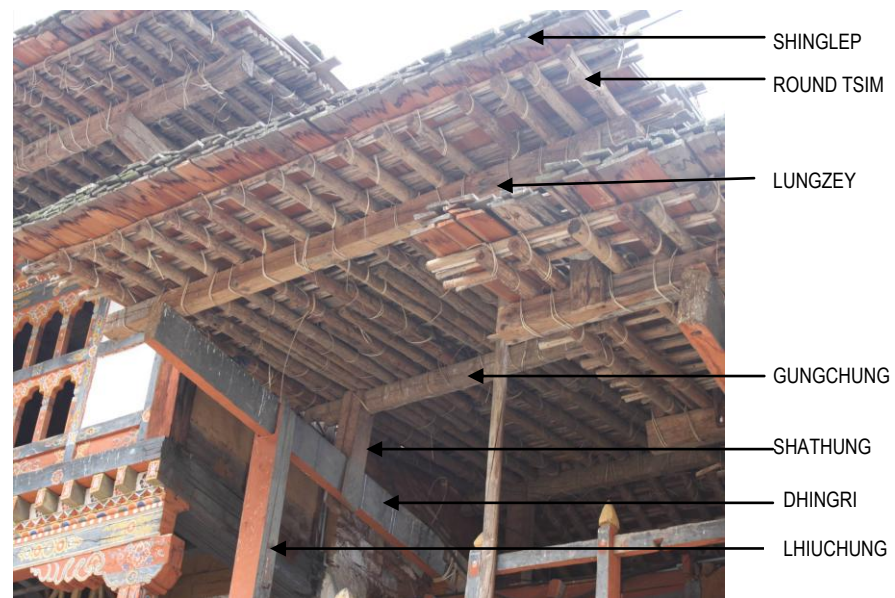

ROOF AT WANGDUEPHODRANG DZONG
(Picture: Dorji Yangki)

**DETAILS OF A TYPICAL GABLE ROOF
COMMONLY USED IN TRADITIONAL
BHUTANESE HOUSES**

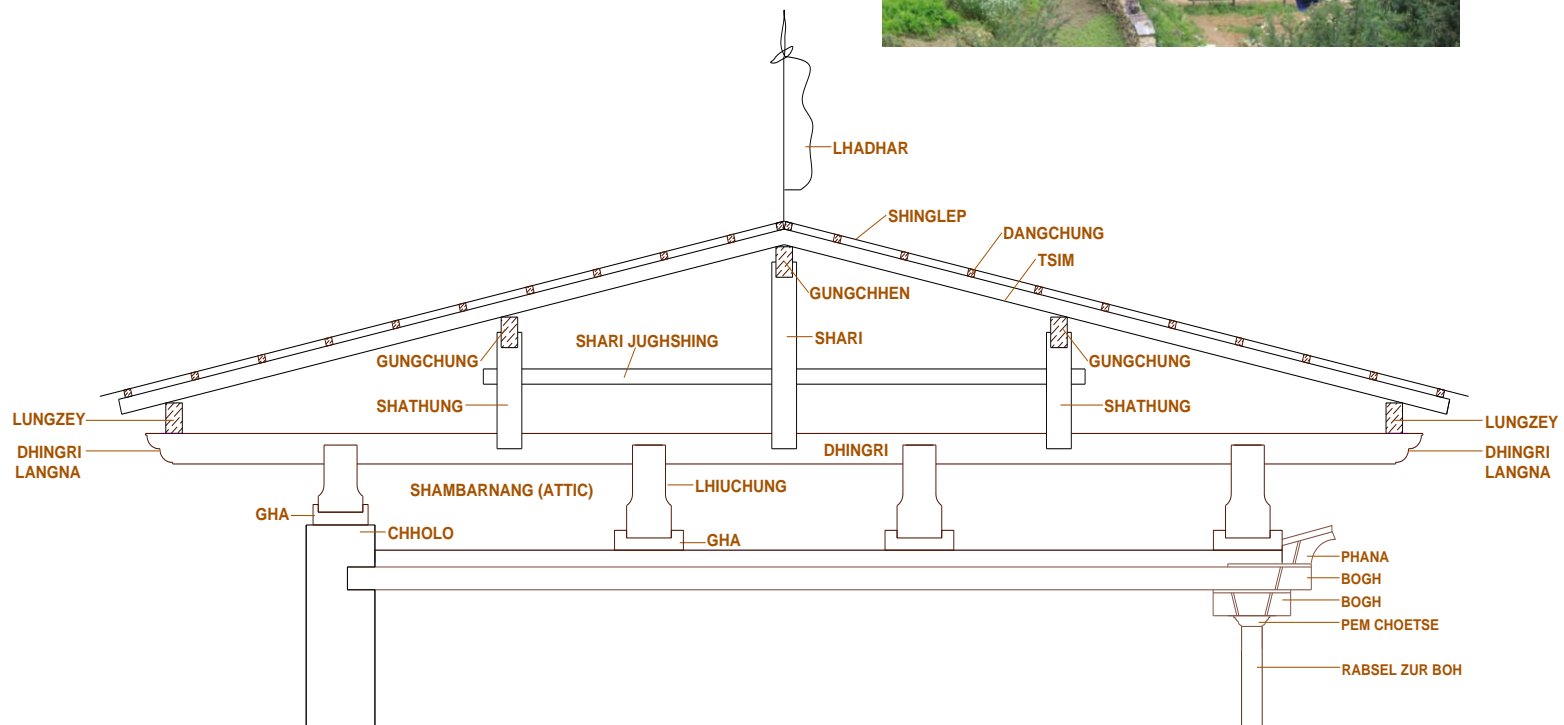

(Drawing & Picture: Dorji Yangki)

JABZHI ROOF

The Jabzhi roof is a square hipped roof with four prominent corners. These roofs were used in buildings of high status such as the Utse of a Dzong or palace or over the building housing the main altar of a Lhakhang.

The Jabzhi roof can be designed with just one roof layer or with several layers of roof to form a pagoda style roof. The roofing material for the Jabzhi roof over these prominent places are usually made of metal plated with gold.

The eaves of the roof are then ringed with a metal curtain embellished with decorative and sacred iconographic carvings known as Chuzha Chulo. Where gold was not available, the Jabzhi roof was then painted in yellow colour to symbolize its sacred and high status.

The four sides of the Jabzhi roof is capped off usually by the heads of auspicious animals like the garuda or dragon or by the scared cared sculpture known as Chuju Patra. These caps are made of brass or copper which are usually gold plated.

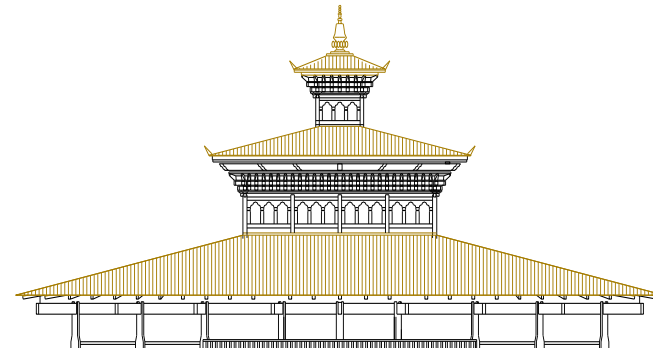

Jabzhi Roof over Goma Kora Lhakhang in Tashi Yangtse
(Picture: Dorji Yangki)

EXAMPLES OF DIFFERENT JABZHI ROOF



Taktshang



Punakha
Dzong

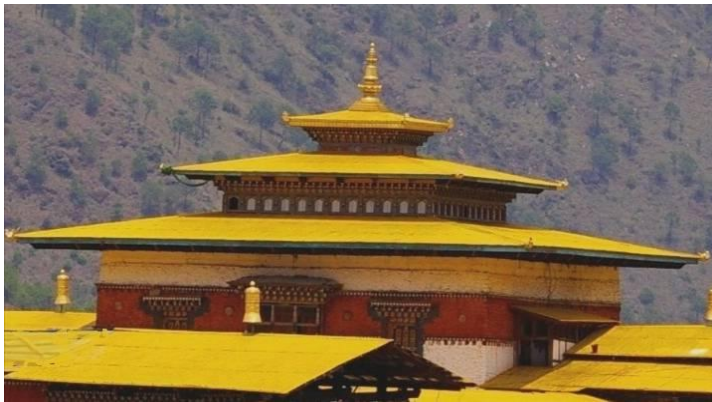

Tashigang
Dzong



Ugyen Pelri
Palace

**THREE LAYERED
JABZHI ROOF**

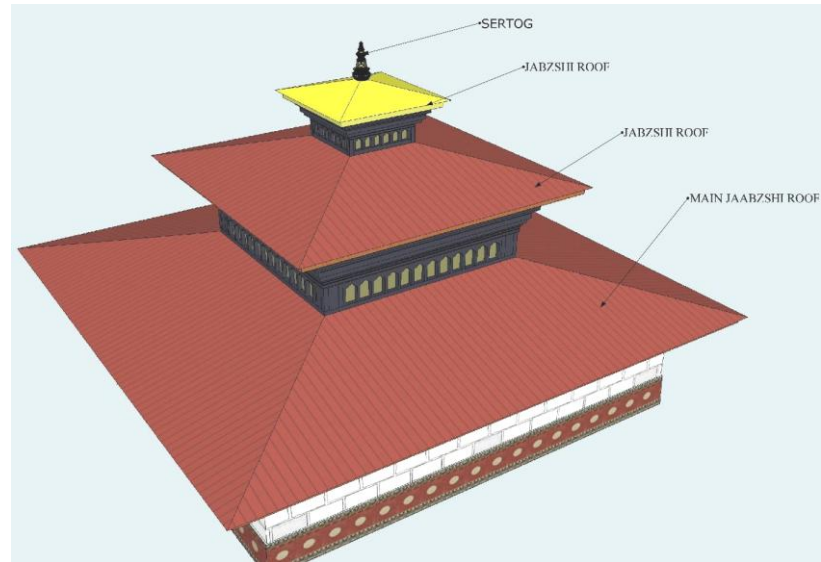

Three layered Jabzhi Roof Detail

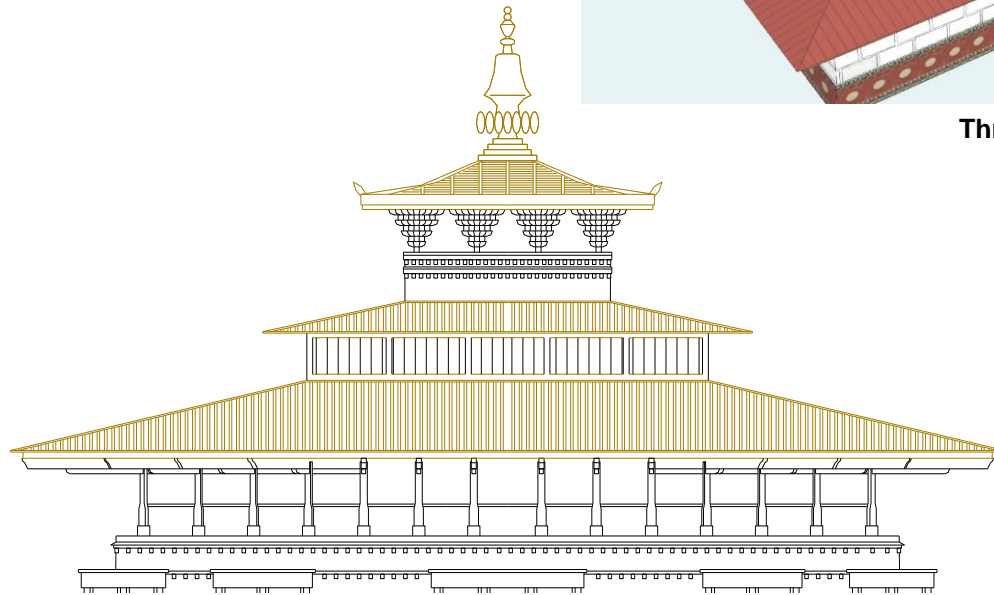

Jabzhi roof of the Utse of Trashichodzong
(Drawing: DCHS, Dept of Culture)

JAMTHOK ROOF

The Jamthok roof in traditional Bhutanese architecture consists of a smaller gable roof laid over a longer gable roof in layers one over the other. This allowed upper layer of the roof to be raised further up to create a much more spacious area in the central area of the attic under the roof.

In the traditional practice of “Thobthang” or entitlement in architecture, this layered Jamthok roof is said to be second in rank to the Jabzhi roof.

The upper layer of the Jamthok roof did not traditionally have windows under it and was left open to allow for air to flow through. However, in some cases, where the attic area was converted into a habitable space, the space under the upper layer of the Jamthok roof was framed into a horizontal line of clerestory windows on two sides and often decorated with Horzhu and Pem Choetse.

The Jamthok roof when it is left open without windows is also often called a Lungo Roof.

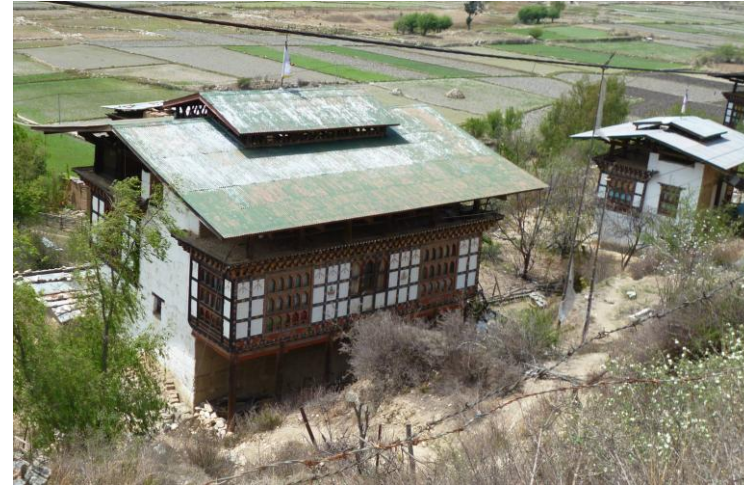

Houses in Paro with Jamthok roof
(Picture: Dorji Yangki)

JAMTHOK ROOF DETAILS

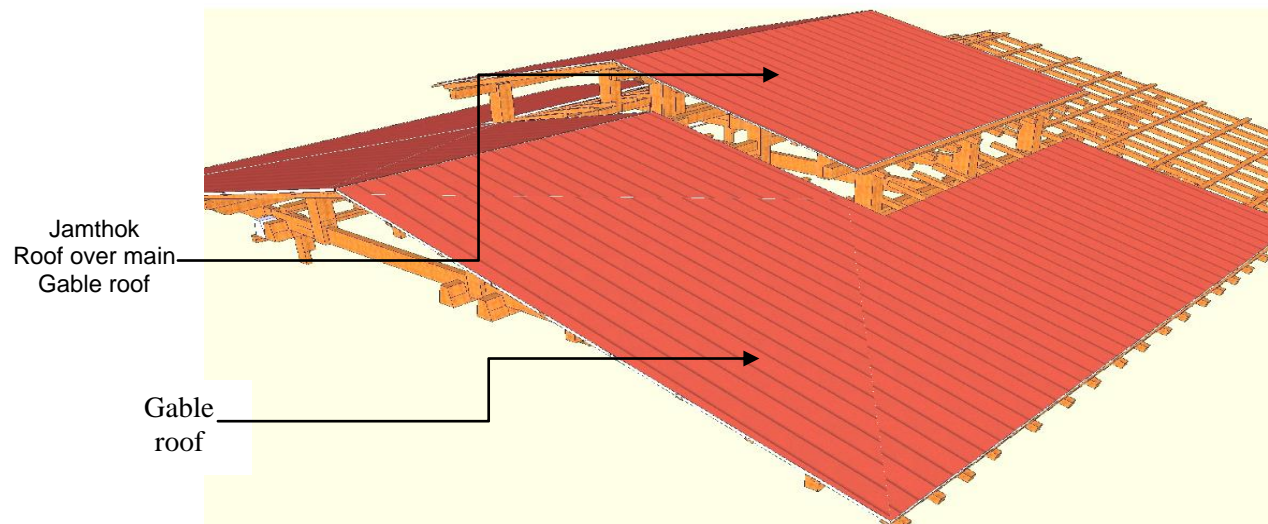
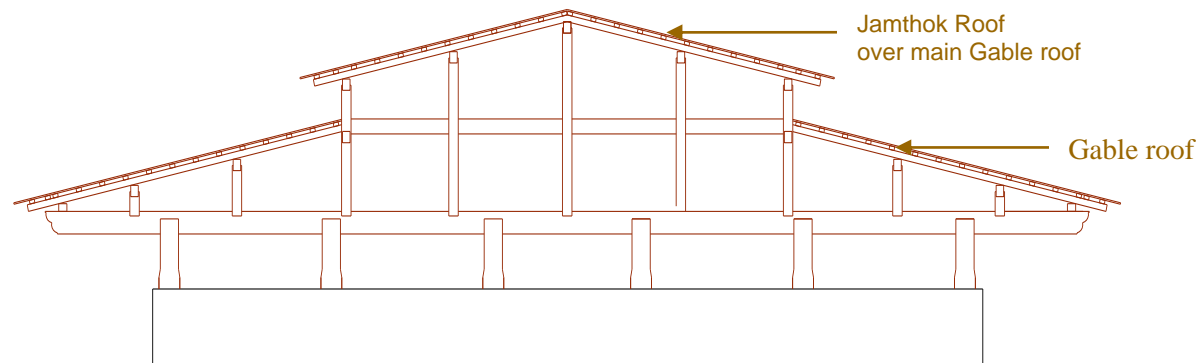

DRANGIM ROOF

The Drangim roof in traditional Bhutanese architecture consists of a gable roof of the same length laid over a lower level gable roof. This allowed upper layer of the roof to be raised further up to create a much more spacious area in the attic under the roof.

The upper layer of the Drangim roof did not traditionally have windows under it and was left open to allow for air to flow through.

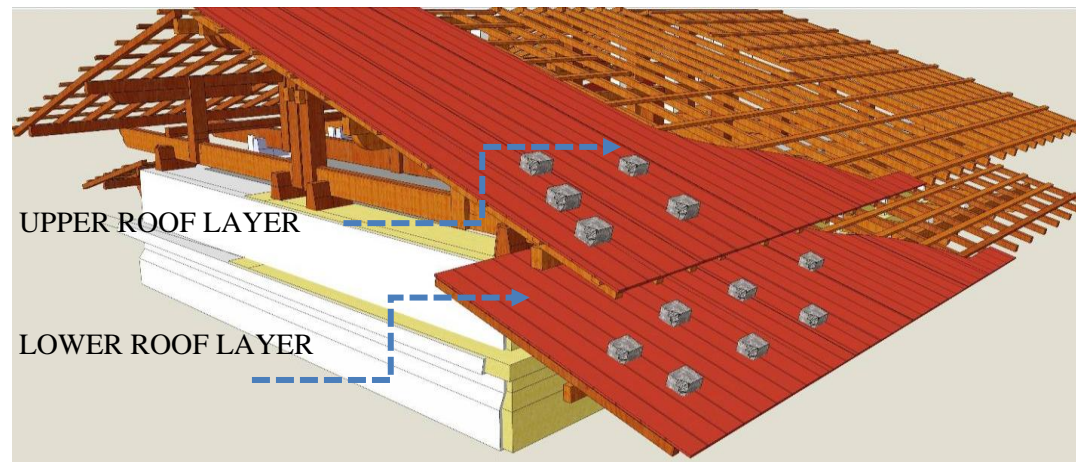

CHENKHAP (LEAN TO ROOF)

The Chenkhep roof is a simple traditional lean-to-roof that is usually installed to provide additional protection to a cantilevering Rabsel. It is laid at a lower level under the main roof of the building.



Chenkhep roof over Rabsel of a House in Thimphu



Chenkhep roof over Rabsel at Dungkhar Nagtshang in Lhuntse



Chenkhep roof over Rabsel at Kunrey of Trashichodzong in Thimphu
(Pictures: Dorji Yangki)

**DETAILS OF
CHENKHEP ROOF OVER RABSEL**

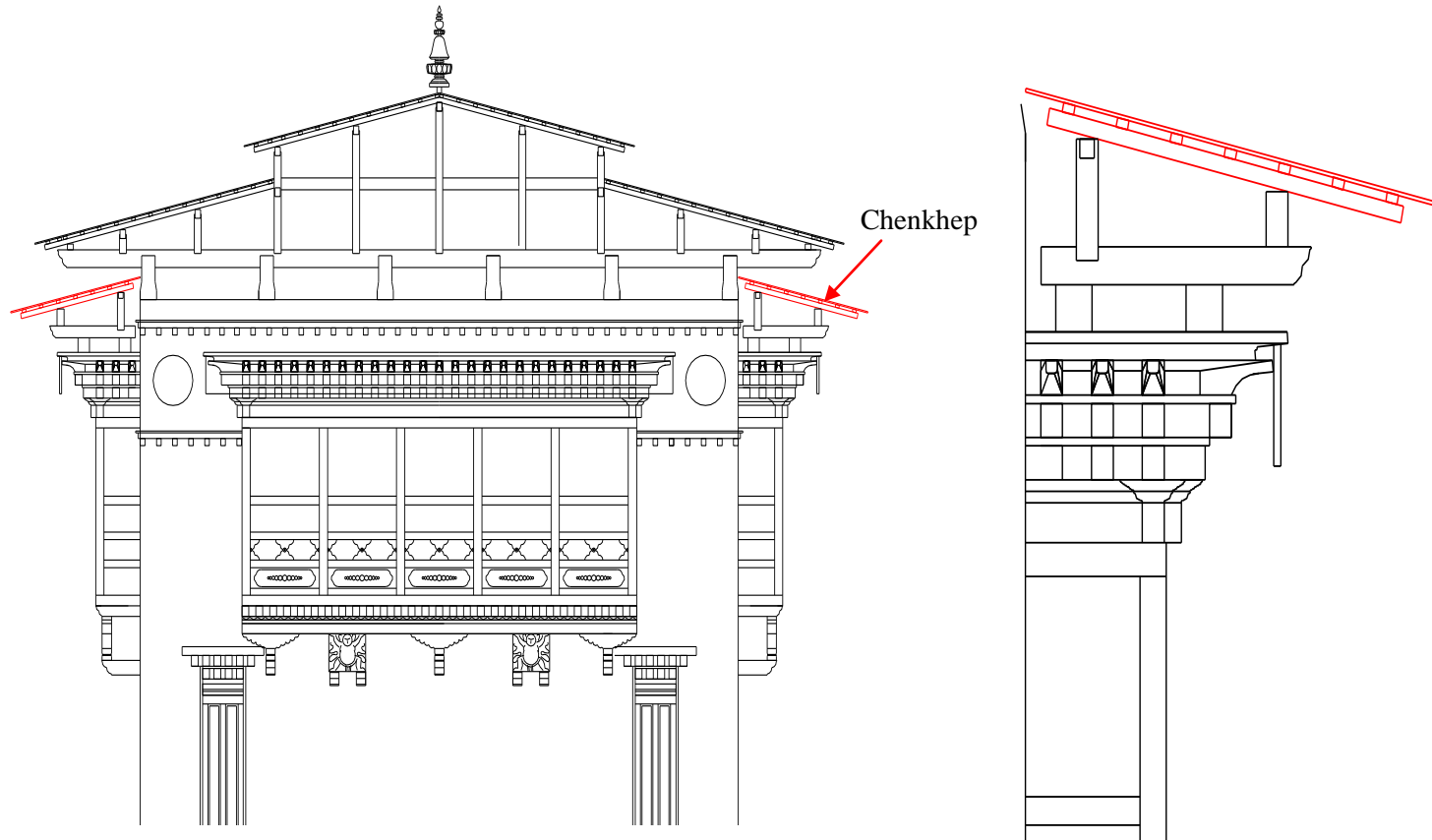

(Drawing: Dorji Yangki)

RABSEL

The Rabsel element in traditional Bhutanese architecture is one of the most significant and beautiful. It mainly consists of timber frame structure with multiple windows and panels that cantilevers from the wall. “Rab” in Dzongkha means “good” and “sel” means “clarity” and the Rabsel was thus named because it provides light and clarity into a building through its multiple window openings and is the main visible architecture component that adds beauty and sophistication to a Bhutanese house.

The Rabsel is generally constructed with a series of vertical and horizontal timber frame components with multiple windows and panels made either out of timber known as Soma or with Shamig which is a wattle and daub infill panel made of bamboo and mud plaster.

The Rabsel usually projects out of the main superstructure. It is supported by the cantilevering ground floor joists known as Tshechu kha-nyim. The Tshechu kha-nyim is usually supplemented with Pem or Pem with Choetse and Dhung. A Rabsel always has cornices Bogh, Phana with Pem, Choetse and Dhung elements.

The Rabsel is designed to either form as continuous frame covering the whole of the upper facade of the building or is broken into smaller bay window type of units known as Lombur Rabsel or Gomang Rabsel. In traditional vernacular architecture the Lombur Rabsel has single or double Shamig panels. The type of windows used in the Rabsel is the Horgo, Gyesargo, Lingo or Boego windows.



House in Paro with Parop Rabsel

(Picture: Dorji Yangki)

**COMPONENTS
OF A TYPICAL RABSEL:**

1. Budhen
2. Thrangcho
3. Bhu (Lenbhu, Jaka)
4. Genthi or Mathoe
5. Keyra Genthi or Barthoe
6. Yathoe
7. Shamig (Ekra)
8. Dhung
9. Pem
10. Choetse
11. Bogh and Boghkhep
12. Cham and Chamkhep
13. Phana or Ngakey and Ngakhep
14. The window members consist of the following.
 - a) Kachung
 - b) Jughshing
 - c) Horzhu or Zing.
 - d) Gochu
 - e) Tshegen



PHOLAY KACHU

PHANA

BOGH

PEM CHOETSE

YATHOE

JAKA

GOCHU WITH HORZHU

JAKA

SHAMIG

MATHOE

THRANGCHO

BUDHEN

TSHECHU KHANYIM

DHUNG

(Picture: Dorji Yangki)

COMPONENTS OF A RABSEL

Budhen

(Bu means middle or intermediate and Dhen means base).

This is the lowest horizontal member that supports the entire vertical frame members known as Bhu, and Zumbhu.

The Budhen is placed directly on the floor joist Tshechu kha-nyim.

The Budhen is fixed with timber dowels and it is square or rectangular in section measuring 6 to 7 inches depending on the floor level of the building.

Thrangcho

The Thrangcho is the horizontal timber plank member fixed just above the Budhen. The Thrangcho timber plank is 200 to 300 mm wide in height.

It traditionally always painted in red colour.

The height of the Thrangcho is said to have been derived from the measurement of a person sitting on the floor. The height should not be too high that a person cannot look out of the Rabsel Window.

The Thrangcho passes through the bottom of all the intermediate Bhu members and gets locked to the Zumbhu with a mortise joint.

Genthi Barthoe Yathoe

The next horizontal timber member fixed above the Thrangcho is called Genthi or Mathoe.

The member above this is Keyra Genthi (also known as Barthoe) and Yathoe. Between the Mathoe, Barthoe and Yathoe members, windows openings are inserted.

The width of these horizontal members is as wide as the width size of the Budhen mainly since it has to accommodate the sliding groove for the shutters.

The thickness of these three members is usually less by an inch to the width.

Zumbhu

The Zumbhu is the corner and end posts of a Rabsel. It is the only post that interlocks the Budhen with a tenon jointing system. The size of the Zumbhu is normally the same as the size of the Budhen.

Shamig and Soma

Between the two window panels in the rectangle frame formed by Horizontal and vertical members, a wall panel called Ekra is constructed with bamboo weave which is then plastered over with mud.

This panel is known as Shamig.

When a timber planks are used this wall panel between the timber vertical and horizontal frames are known as Soma.

Bhu

Between the two Zumbhu members there are vertical post generally called as Bhu. But depending on its position they too have individual names.

The Bhu that frames the sides of the window is known as Jaka. The Bhu between the Zumbhu and Jaka or between two Jaka is called Lenbhu.

The Bhu members saddle over the Thrangcho. Traditionally Bhu members are not interlocked to the Budhen. The front width of Bhu is same as horizontal members but the depth of Bhu varies between Jaka and Lenbu. The Jaka is a square member whilst Lenbu depth is same as Budhen.

Dhung

The load of the entire Rabsel rests on a timber lintel members called Dhung which is sometimes embedded in the wall.

To support a cantilevering Rabsel structure to the building walls, a cross beam Dhung at the Yathoe level is provided. The ends of such Dhung are anchored deep into the wall and in order to prevent the tilting of the Rabsel, it is slightly tilted towards the wall at the Dhung level by a half or one inch. At the floor level the Budhen is fixed to Tshechu kha-nyim with timber dowel.

Gochu

The window openings in a Rabsel are called Gochu. The Gochu are usually in two or three tiers of windows. The window opening consists of Kachung and timber motif with carvings called Horzhu or Zing.

DETAILS OF A TYPICAL RABSEL

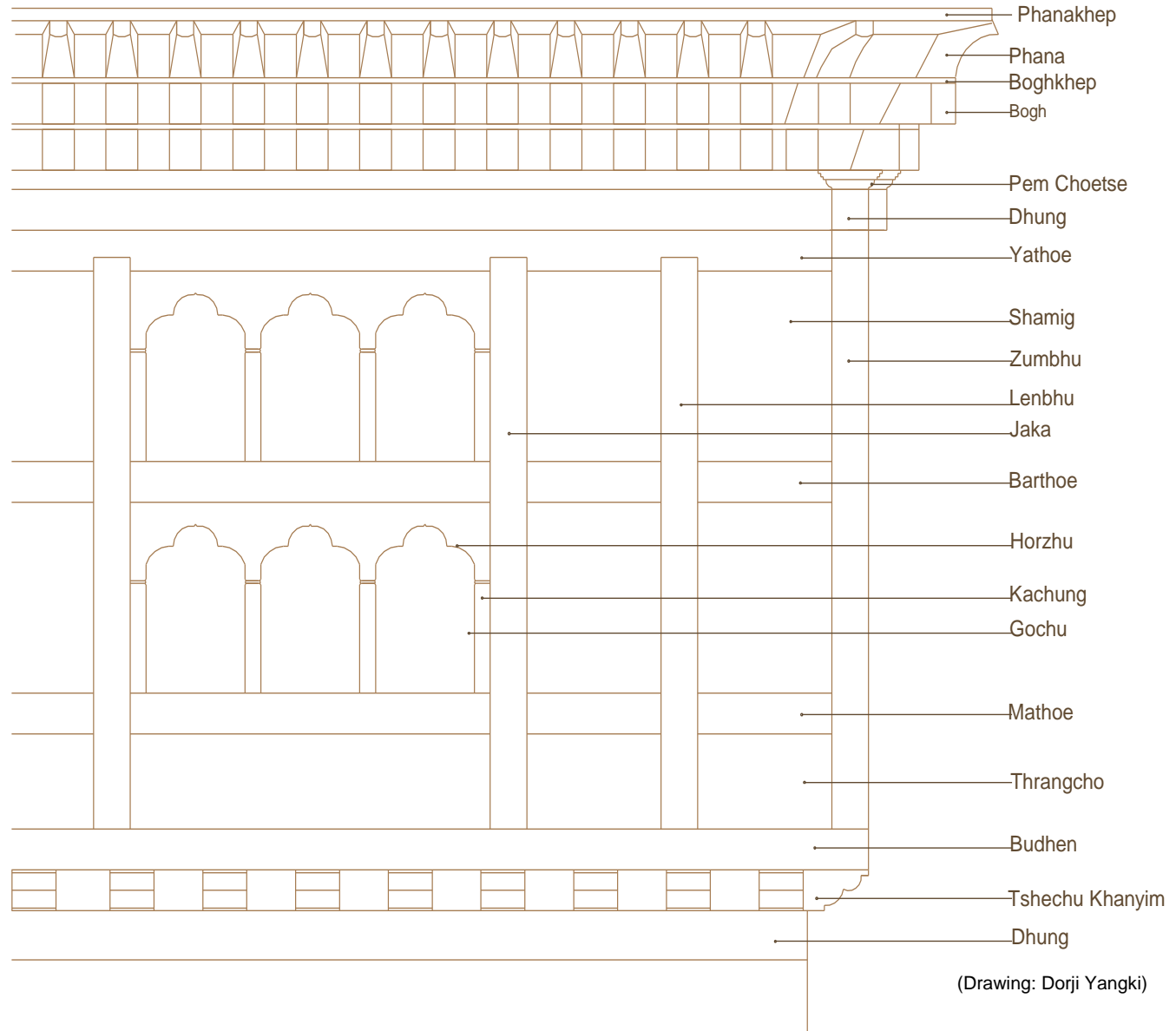

TYPES OF RABSEL

The Rabsel can be categorized into four main types based on the secondary architectural elements that it is constructed with:

- 1. Rab- Langna-Drezhu-Gyetse**
This is a Rabsel with all the secondary elements and is the most intricate and elaborate of all Rabsel.
- 2. Ding- Sa-dung-Pem-Choetse**
The Ding category refers to a Rabsel that is less intricate than the Rab Rabsel. It does not have Langna Drezhu and the Dhung sits directly on the Jang (wall).
- 3. Tha--Sa-dung-pem**
This Rabsel does not have Choetse and is less intricate than the Rab and Ding Rabsel.
- 4. Thali tha-Jangu Budhen**
This Rabsel is the most basic Rabsel. It does not have Pem Choetse and the Dhung sits directly on Jang (wall).

CATEGORIES OF RABSEL

Around 7 main different types of design for Rabsel can be are categorized in traditional Bhutanese architecture as follows:

1. Rabsel Go-Cham Thognyim
2. Parop Rabsel
3. Byelgo Rabsel
4. Gyesargo Rabsel
5. Lingo Rabsel
6. Nimchu Rabsel
7. Gomang Rabsel
8. Lobur Rabsel

RABSEL GO-CHAM (GO -CHHA) THOGNYIM

This style of Rabsel is the most common and can be found all over the country with very little variation from region to region.

This Rabsel's main distinguishing feature is the fact that it has two tiers of Gochu window. This type of Rabsel is also used predominantly in dwellings and in Dzong, palaces and temple complexes and it is mainly used in areas used for living spaces of the residents.

In farmhouses and dwellings, there is slight variation of the design of this Rabsel in Western Bhutan compared to this type of Rabsel in the East of Bhutan.

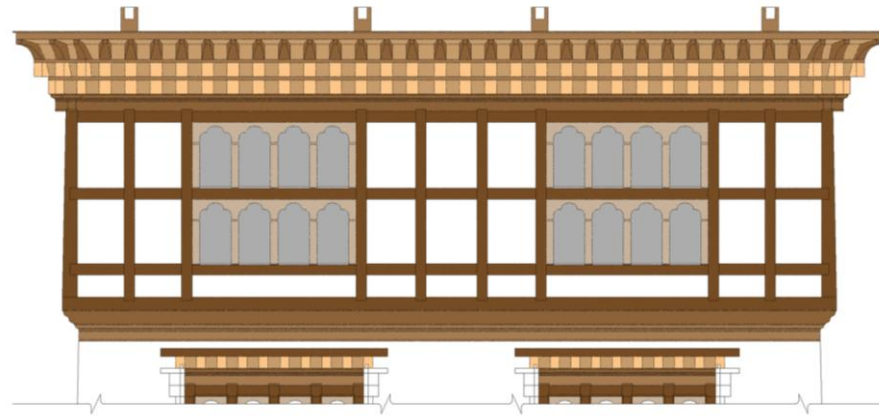

HOUSES WITH RABSEL GO-CHAM



Houses in Punakha, and Wangduephodrang with Rabsel Go Cham
(Pictures: Dorji Yangki)

PAROP RABSEL

The Parop Rabsel which is taller than the Rabsel Gocham consists of three tiers of windows separated by two Keyra Genthi or Barthoe. This type of Rabsel is very commonly found in Paro and thus this Rabsel is known as Parop Rabsel.

This Rabsel is also used in buildings such as Dzong where there is a need to have rooms of higher floor to ceiling heights than normal since the three tier windows allows the Rabsel to be taller. Generally the height of Thrangcho in the Parop Rabsel is smaller compared to Rabsel Gocham Thognyim.

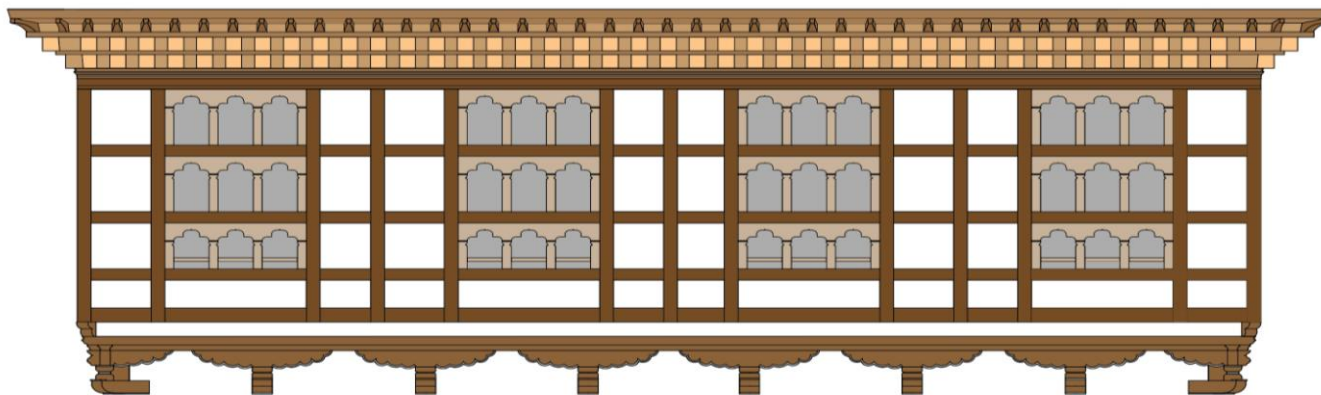

**PAROP RABSEL
ILLUSTRATION**

(Dwg: Thinley Pemo)

HOUSES WITH PAROP RABSEL



Houses in Paro and Thimphu with Parop Rabsel

(Pictures: Dorji Yangki)

BYELGO RABSEL

The Byelgo Rabsel is an older style of the Rabsel which can be found in ancient medieval Bhutanese dwellings. Very few of these Rabsel still exist today.

The Byelgo Rabsel is said to be easier to construct as this Rabsel has only a single tier of windows without the small members of Kachung and has large open spans from Bhu to Bhu. In the Byelgo, the Rabsel height is divided into three sections like in the Parop Rabsel but this is done without the Thrangcho.



BYELGO RABSEL: FARMHOUSE IN PARO
(Picture: DCAH, Doc)

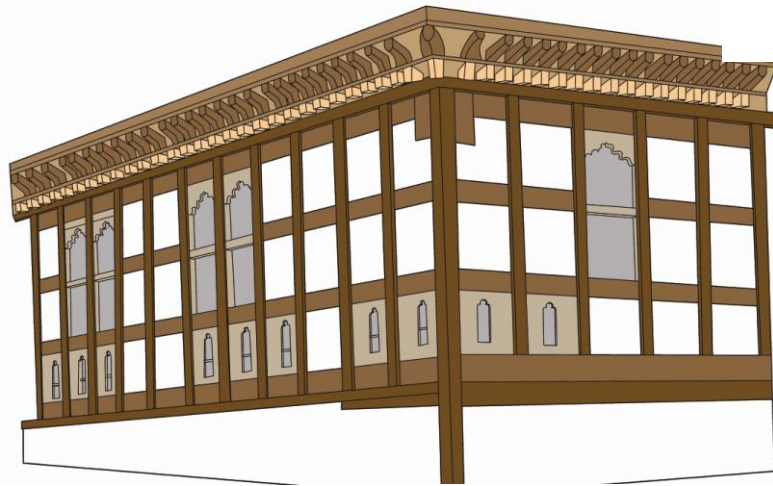

BYELGO RABSEL ILLUSTRATION

(Drawing: Aman Pulami)

The lower one third segment of the Byelgo Rabsel consists of the Soma timber panel between the timber frames whilst the remaining upper two third segment of the Rabsel is converted into window openings. The second Barthoe doesn't continue into the window openings. A horizontal timber Jughshing is inserted instead to create the division in the window opening.

In the remaining timber frames on either side of the windows, timber planks known as Soma are used in the place of the bamboo wattle and mud daub known as Ekra. For practical purposes, in order for people sitting on the floor to get a view of what's happening outside the house, a small window is sometimes carved into the lower Soma panel.

This little window is known as Soma Gochu. A Byelgo Rabsel may or may not have Soma Gochu so this little window is not essential part of the Byelgo Rabsel. In Traditional vernacular architecture, the Byelgo Rabsel sometimes does not cantilever out like Parop Rabsel or Rabsel Thognyim. It is placed directly on the wall. However it is still built with Bogh, Phana and Pem Choetse on the top of the Rabsel frame.



BYELGO RABSEL OF A FARMHOUSE IN PARO

(Picture: MOWHS)

NYIMCHU RABSEL

The Nyimchu Rabsel is a version of a Rabsel that encloses an open balcony. It is usually constructed without any windows and has open timber posts instead. It is also usually constructed with a roof over the Rabsel. Instead of Zing or Horzhu, the timber Bhu posts are capped with Zhu on top like a little capital over a column post.

In the Nyimchu Rabsel, between the Bhu posts, the traditional railing Jadhang Tazi is installed. Generally the Nyimcho Rabsel is not kept fairly simple without cornices in farm houses. In special buildings such as Dzong and Palaces, the Nyimchu Rabsel is installed with two layers of Bogh with Phana layer on top.



EXAMPLES OF NYIMCHU RABSEL



(Pictures: Dorji Yangki & Nagtsho) Dorji)

GOMANG RABSEL

The Gomang Rabsel looks similar to the Nyimchu Rabsel but the Gomang Rabsel does not have Jadhang Tazi between the Bhu (timber post frame) and the space between each Bhu is much smaller.

There is also usually a series of doors that lead into the Rabsel balcony space which is why this Rabsel is known as Gomang or “many doors” Rabsel.

In traditional vernacular architecture, the Gomang Rabsel does not have Horzhu between the Bhu. In place of the Horzhu element, a simple Zhu is used on the Bhu especially when the spacing between them is large.

The Gomang Rabsel are stand-alone components and are found one on top of another with the same projection or sometimes projecting out consecutively from the lowest Rabsel to the topmost Rabsel.

The Gomang Rabsel is usually protected from the sun by a Nyimkhep made of timber or metal which hangs down over the Bogh and Phana elements.

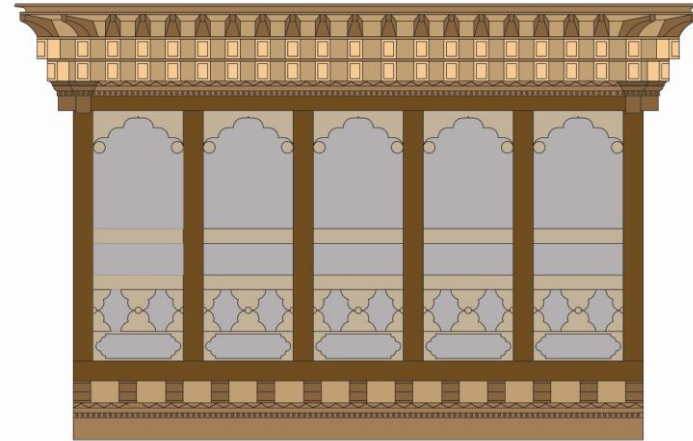

(Drawing: Aman Pulami)

GOMANG RABSEL EXAMPLES



(Pictures: Dorji Yangki)



Gomang Rabsel at Lhakhang Sarp at Trashichodzong
(Picture: Dorji Yangki)

GYESARGO RABSEL

The Gyesargo is a window that is said to have originated in a place called Ling in Tibet. It is called Gyesar because King Gyesar hails from Ling.

The Gyesergo is a large rectangular opening as wide as door (Go) between the Budhen and Yathoe with Horzhu and is as wide as Shamig or Soma panel. It has a very low Thrangcho and Jughshing at the Barthoe level.

The Gyesargo is generally found on a Rabsel only and not as an individual window alone.

The Gyesago Rabsel is fairly rare and is found in very few ancient houses. It can also be seen at the Folk heritage Museum farmhouse.



Gyesargo Rabsel at the Folk Heritage Museum

(Pictures: Dorji Yangki)

LINGO RABSEL

The Lingo Rabsel is similar to the Gyersargo Rabsel except for the fact that the windows are in the Lingo style which does not have any Horzhu.

The window opening is also kept as wide as the timber Soma panel. Often a Jadhang Tazi is also installed for railing protection since the openings can be as wide as a door. It also has a low Thrangcho like the Gyersargo Rabsel.

The Lingo Rabsel with its simple design is often considered to be of lower hierarchy to a Rabsel with Horzhu and is thus kept at the lower level Rabsel when a tiered level of several Rabsel are used stacked one on top the other.



Lingo Rabsel at Tharpaling in Bumthang

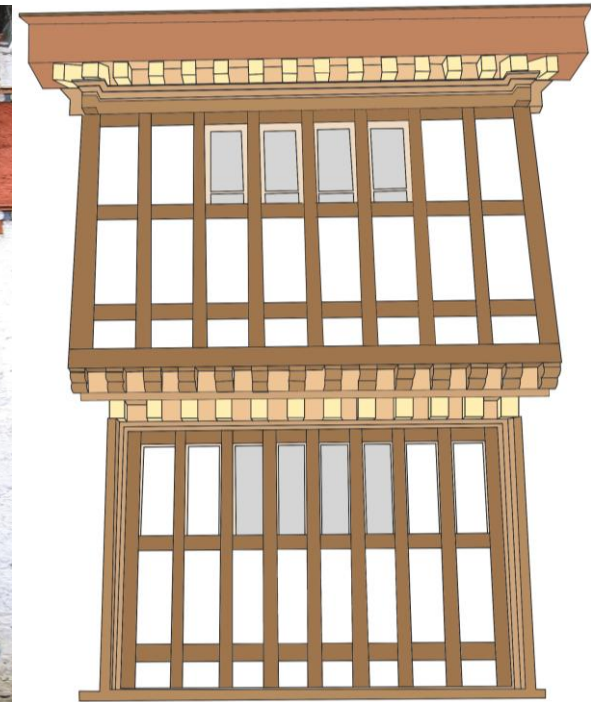

Lingo Rabsel Illustration
(Drawing: Thinley Pemo)

LOBUR RABSEL

The Lobur Rabsel which is like a bay window is designed with elements similar to those found in the Rabsel Thognyim and the Parop Rabsel.

The main differences are that it is designed as a single unit and covers just a segment of the wall facade rather than the entire upper level of the wall that is usually found in the design of the Parop Rabsel and the Rabsel Thognyim.

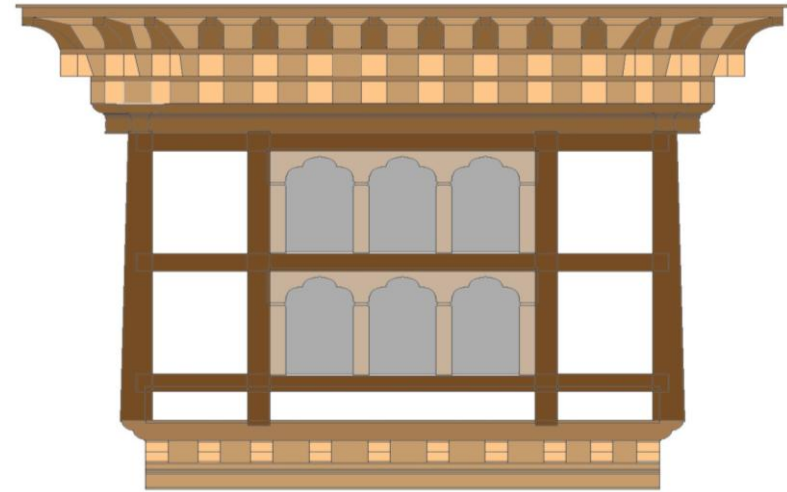

(Pictures: Choening Dorji & Dorji Yangki; Drawing: Phub Om)



(Picture: Namgey Retty)

SECONDARY BHUTANESE ARCHITECTURAL ELEMENTS

1. Bogh
2. Phana
3. Pem
4. Choetse
5. Tshechu Kha-Nyim
6. Norbu Bagum
7. Norbu Horzhu Gyetsa
8. Keymar
9. Nyim Khep
10. Sertog
11. Gyeltshen
12. Lhadhar
13. Mythical Animal Sculptures

BOGH AND PHANA

Bogh and Phana are traditional Bhutanese cornices. The Bogh is an end of the extension of the Cham or interior timber joist for ceiling or upper floor levels that are set to project outside the wall as cornices.

The Phana which is a timber cornice shaped like a pig's nose or neck of a duck is laid over the Bogh.

Generally the Bogh and Phana are laid over the Rabsel which consists of the elements Pem, Choetse, Bogh, Boghkhep, Cham, Chamkhep, Phana and Phanakhep.

On most traditional old buildings only one layer of Bogh and Phana are used in a Rabsel. The double layer of Bogh and Phana was found mainly in Dzongs. The Bogh and Phana elements are also laid over traditional windows, doors and sometimes Kachen and Zhu.

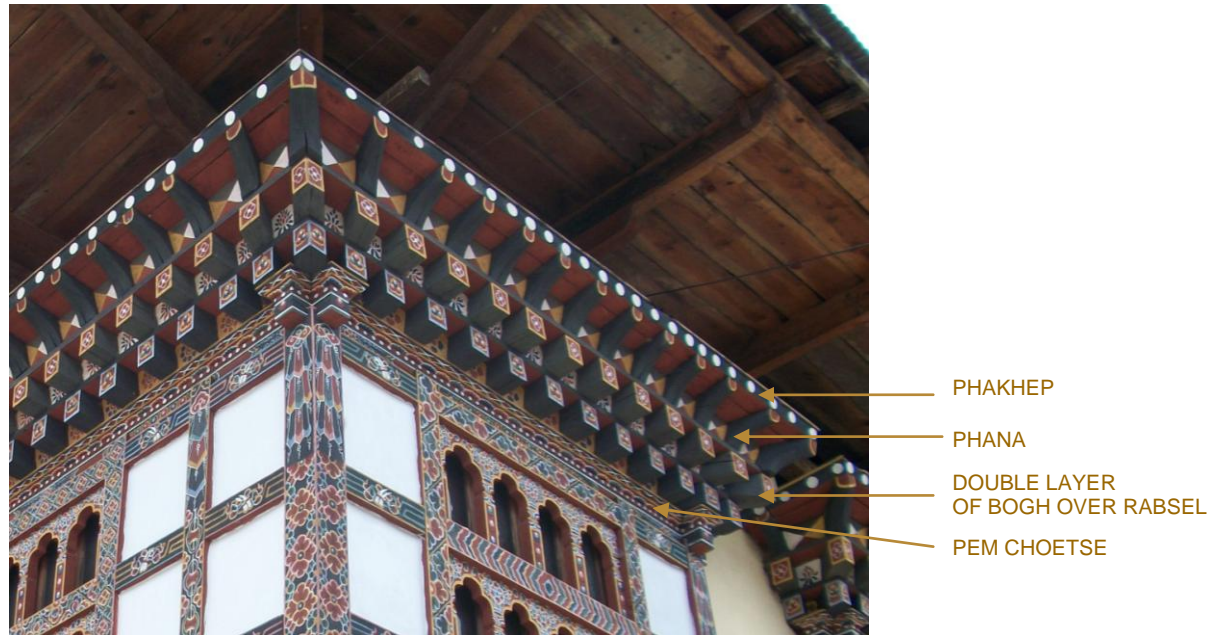

PEM AND CHOETSE

The Pem and Choetse elements are usually found together as a component over the Beam (Dhung) and below the Bogh and Phana components. The Pem which is painted onto a timber lintel portrays the sacred lotus flower, while the Choetse which is laid over the Pem painting and is usually carved into the timber represents a stack of prayer books. In some cases the Pem is used without the Choetse element. When the Pem and Choetse component is laid to decoratively frame a door or window they can be installed around the door and window without the Dhung





TSHECHU KHA-NYIM

The Tshechu Kha-nyim is the special shaped projecting floor joist (Cham) that cantilevers externally beyond a wall to provide support to a Rabsel.

The Tshechu Kha-nyim is usually supplemented by a Dhung (lintel beam) below it which is sometimes embedded into the wall. The decorative elements of Pem and Choetse are often included below the Tshechu Kha-nyim and above the Dhung.



Tshechu Kha-nyim with embedded Dhung and without Pem Choetse below Rabsel window at Semtokha Dzong

Tshechu Kha-nyim with Pem Choetse below Rabsel at Dodedra Lhakhang
(Pictures: Dorji Yangki)

NORBU BAGUM

The Norbu Bagum is a set of interlocking square timber bracket components fixed with joints like an intricate inverse mountain block of jutting cubes. The Norbu Bagum element is fairly rare and is usually found only in Dzong and special Lhakhangs. These decorative supporting elements is said to be designed as paths of offering to the Gods and Spirits.

The Norbu Bagum can be placed below a Rabsel, above a Rabsel or as part of the roof structure to hold a Sertog. The Norbu Bagum is rarely found in farm houses or dwellings.

A Norbu Bagum when laid under a Rabsel is usually laid over a supporting decorative element known as Gyetsa.

When the Norbu Bagum is placed over a Rabsel bay window it is usually installed with Pem Choetse and Dhung under layers of Bogh and Phana.



Norbu Bagum below Rabsel at Gantey Goenpa
(Picture: Dorji Yangki)

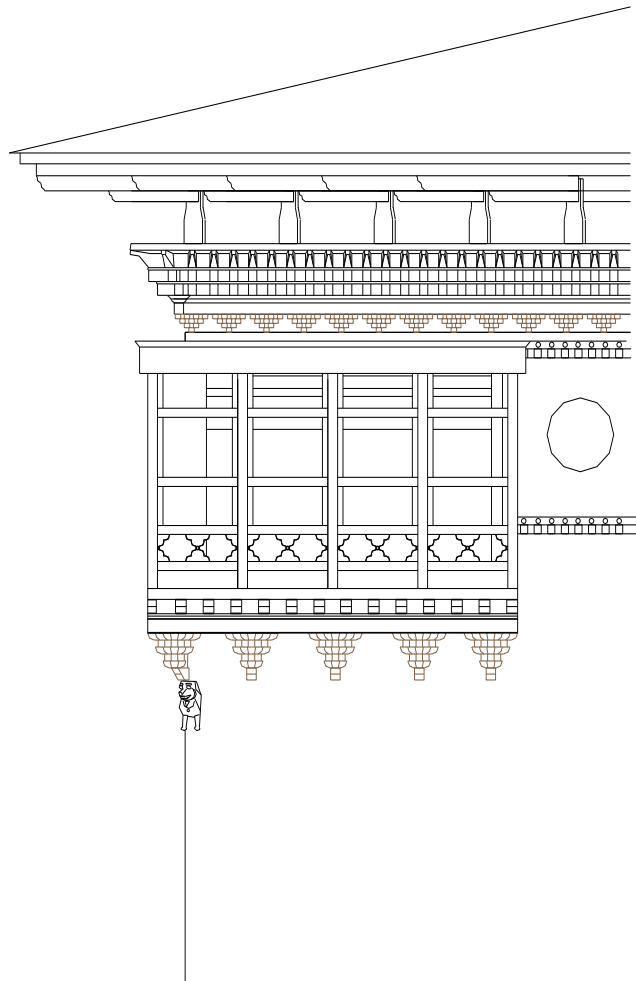

Norbu Bagum below Rabsel at Gantey Goenpa

(Picture & Drawing: Dorji Yangki)

**NORBU BAGUM UNDER
ROOF WITH SERTOG**

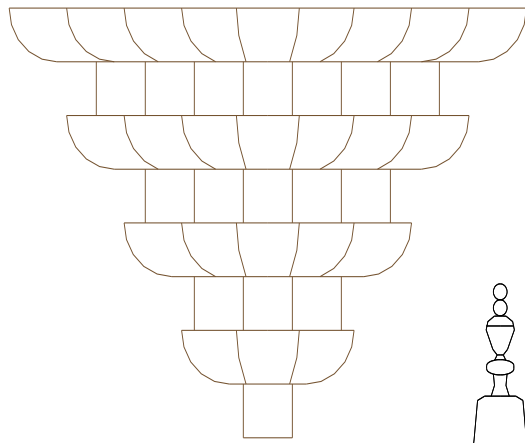

**Norbu Bagum
drawing details**

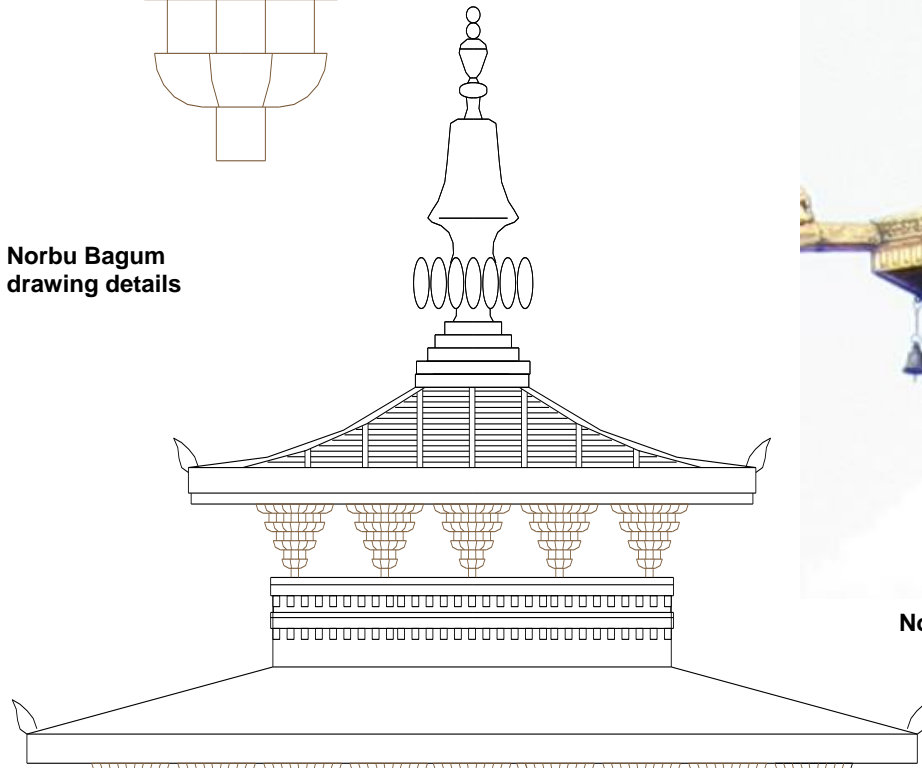

(Drawing: Dorji Yangki)



Norbu Bagum on Roof at Jambay Lhakhang in Bumthang

NORBU HORZHU

The element Norbu Horzhu is usually carved or painted on a timber block. It consists of three Norbu (precious jewel) framed together by three curved motifs as shown in the picture.

The Norbu Horzhu is usually installed as a component with Pem Choetse.

This element is located on the top of Rabsel, but in religious buildings they are also installed below the Rabsel if Bogh layers are used under the Rabsel instead of a Tshechu Kha-nyim.

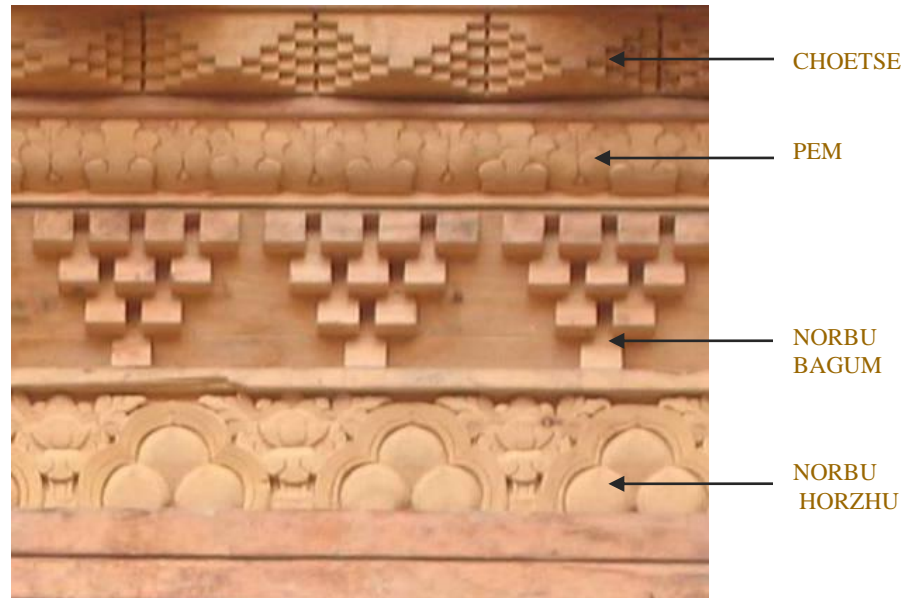

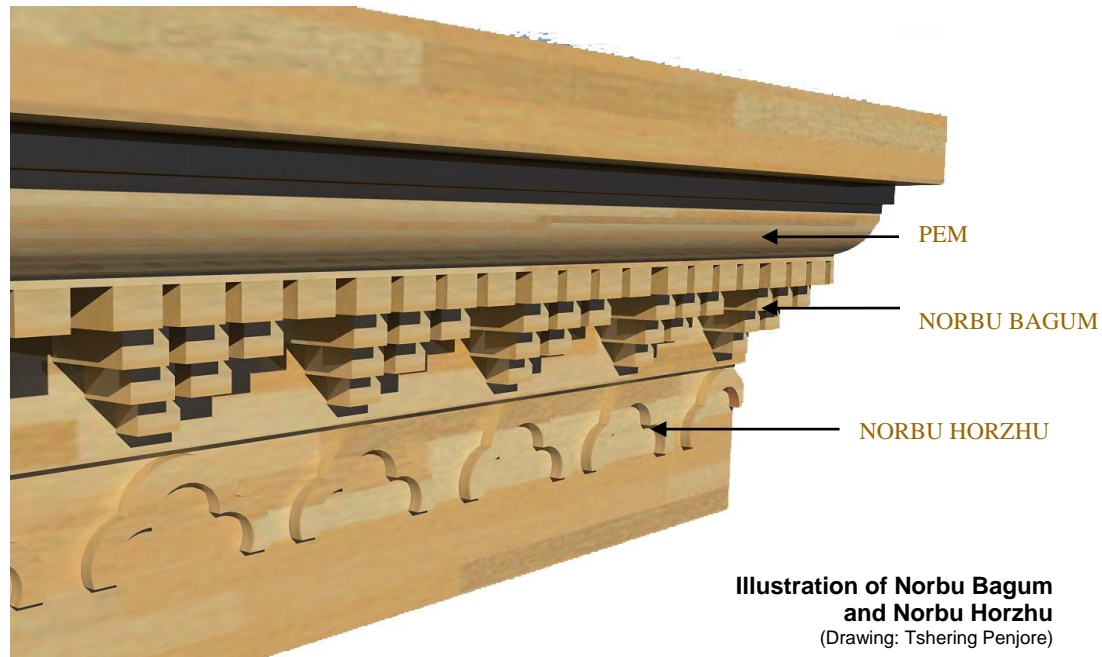



Gyetsa at Gantey Goenpa
(Picture: Namgay Retty)

GYETSA

The Gyetsa is a timber element that cantilevers from the wall. It is responsible for the support of the Drezhu and the Rabsel above.

The Gyetsa form can be in two different shapes:

1. In the form of Tshechu kha-nyim or Langna (nose of the bull).
2. In the form of Mythical animal heads.

While the Gyetsa in dwellings is usually in the form of Langna, in religious buildings, Dzong and Palaces mythical animal heads carved in timber are mainly used for the Gyetsa.



Gyetsa (Picture: Jamyang S. N)

**GYETSA IN THE FORM OF LANGNA
IN A FARM HOUSE IN CHANGJIJI**

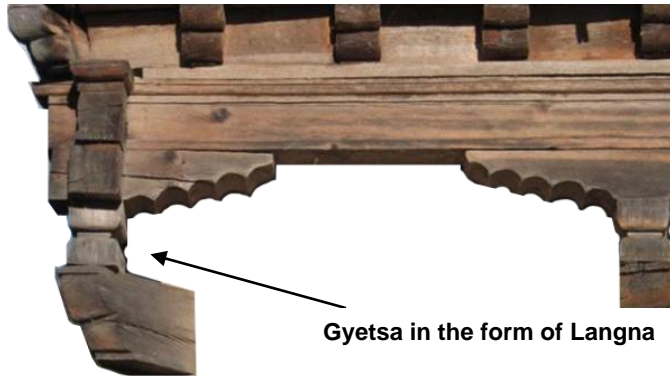

Gyetsa in the form of Langna

(Pictures: Dorji Yangki)



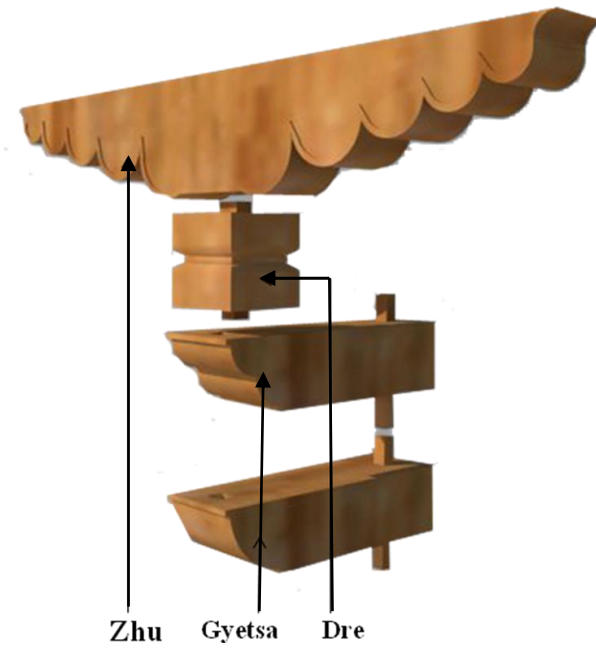
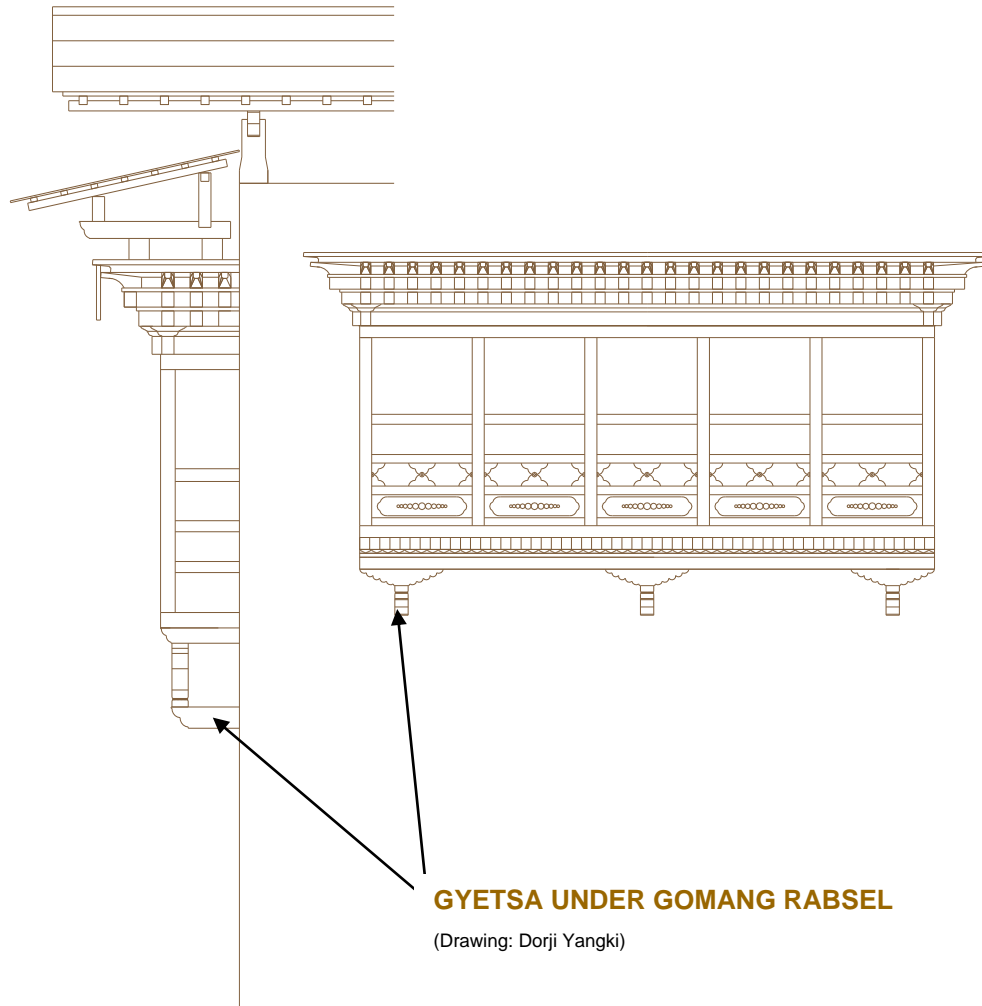

(Illustration: Tshering Penjore)

KEYMAR

The Keymar is a wide band around the external walls of a building that marks the structure as a sacred religious place. The Keymar is usually red in colour but in certain Lhakhang and Choetens the Keymar is also black or grey in colour.

The Keymar is left simple or is usually framed by Bogh on the upper and lower sides with a timber lintel band. On the Keymar at intervals, round motifs to represent the Sun and the Moon are often painted on or installed in plates made of copper plated with gold.

The Keymar is located along the upper levels of the walls of a building or Choeten. Where there are Rabsel, the Keymar is installed or painted in line with the upper middle level of the Rabsel but is in general never placed below a Rabsel.

The standard rule of thumb is to ensure that there is a measure of at least half the width of the Keymar of wall space above the Keymar as shown in the drawing.



Keymar at Jambay Lhakhang in Bumthang
(Picture: Dorji Yangki)

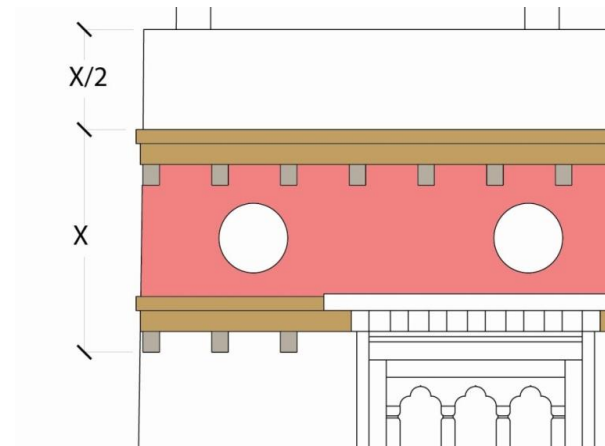

Keymar and Wall proportion
(Drawing: Jamyang S. N)

DIFFERENT STYLES OF KEYMAR

Simple Keymar
without Bogh at Choeten
Kora



Double Keymar
in red and
grey colours
at Tamshing
Lhakhang

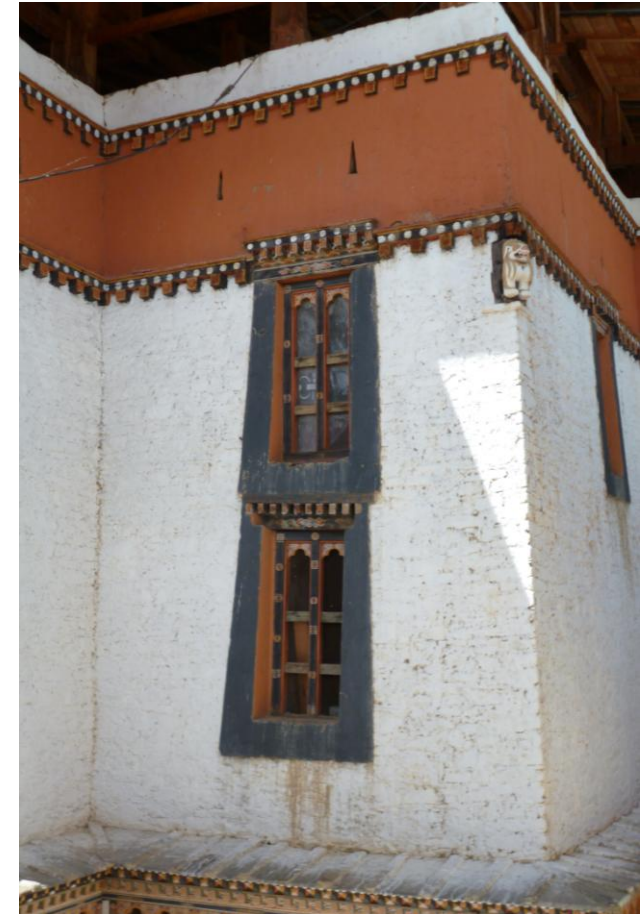

Keymar with Bogh at Semtokha Dzong

(Pictures: Dorji Yangki)



DETAILS OF KEYMAR AT JAMBAY LHAKHANG & KEYMAR AT DEMA LHAKHANG

NYIM KHEP

In Dzongkha, “Nyim” means Sun and “Khep” means cover or shade. The Nyim Khep in traditional Bhutanese architecture is thus usually a timber panel which is placed over a Rabsel window to protect the residents from the Sun.

This element is usually only found mainly on windows and balconies of religious buildings. The external visible side of the Nyim Khep panel is usually decorated with carvings or painted with floral motifs, mythical animals and religious symbols and iconography.

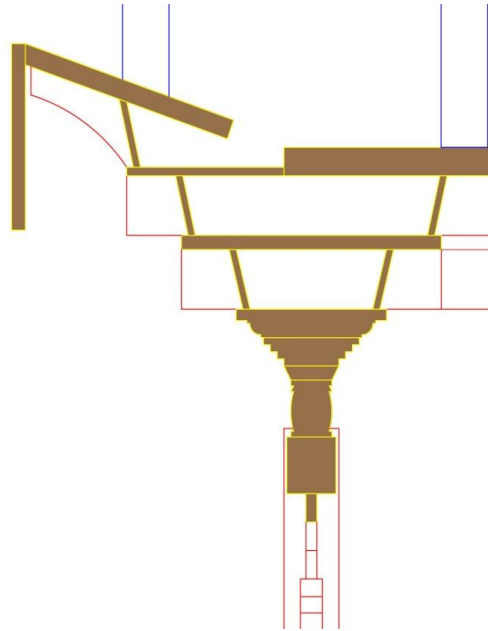

(Picture: S. N)

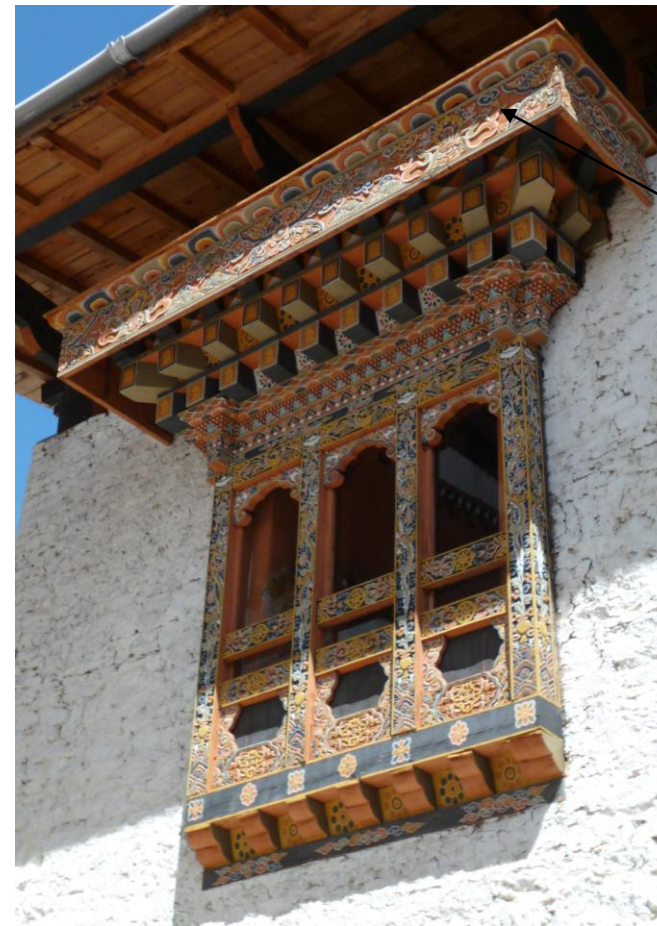

Nyim Khep

Nyim Khep over Rabsel window at Semtokha Dzong

(Picture: Dorji Yangki)

DIFFERENT TYPES OF NYIM KHEP



Nyimkhep over Gomang
Rabsel at Semtokha Dzong



Nyimkhep over Door and
Window at Gantey
Goenpa

(Pictures: Dorji Yangki)

SERTO

“Ser” in Dzongkha means gold and “Tog” means tip or pinnacle. The Sertog element in traditional Bhutanese architecture is usually made from beaten copper or brass which is gold plated by local artisans.

The Sertog element in traditional Bhutanese architecture is said to be the highest level of entitlement signifying highest sacred ranking, position of command and mark of highest form of respect in the land. The Sertog was thus usually placed only on top of the roofs of Lhakhang, Choeten, Dzong and the main royal chambers in palaces of Monarchs.

The Sertog, in general, is placed on top of a Jabzhi type of roof made of metal plated in gold or painted yellow. The eaves of the Jabzhi roof was normally also decorated in a curtain of gold plated metal with intricate carvings and embossments. This curtain plate is known locally as Chuza Chulo. The corner edges of the Chuza Chulo are normally capped with the decorative elements known as Chunju Patra.

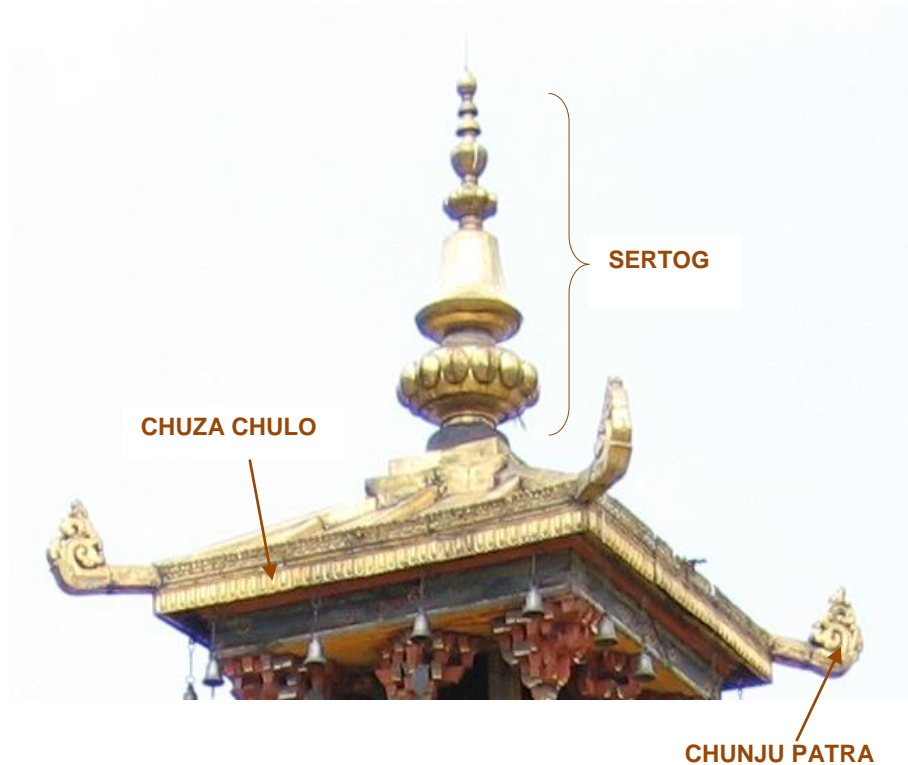

Sertog at Jambay Lhakhang

ELEMENTS OF THE SERTOOG

The Sertog is composed of mainly five elements. This includes the Bell element and two layers of the lotus flower (Pem) which are said to symbolize the six transcendental virtues in Buddhism.

The holy water vase known as Bumpa symbolizes the seven branches of awakening. The precious jewel on top of the Sertog known as Norbu symbolizes fulfillment of all wishes.

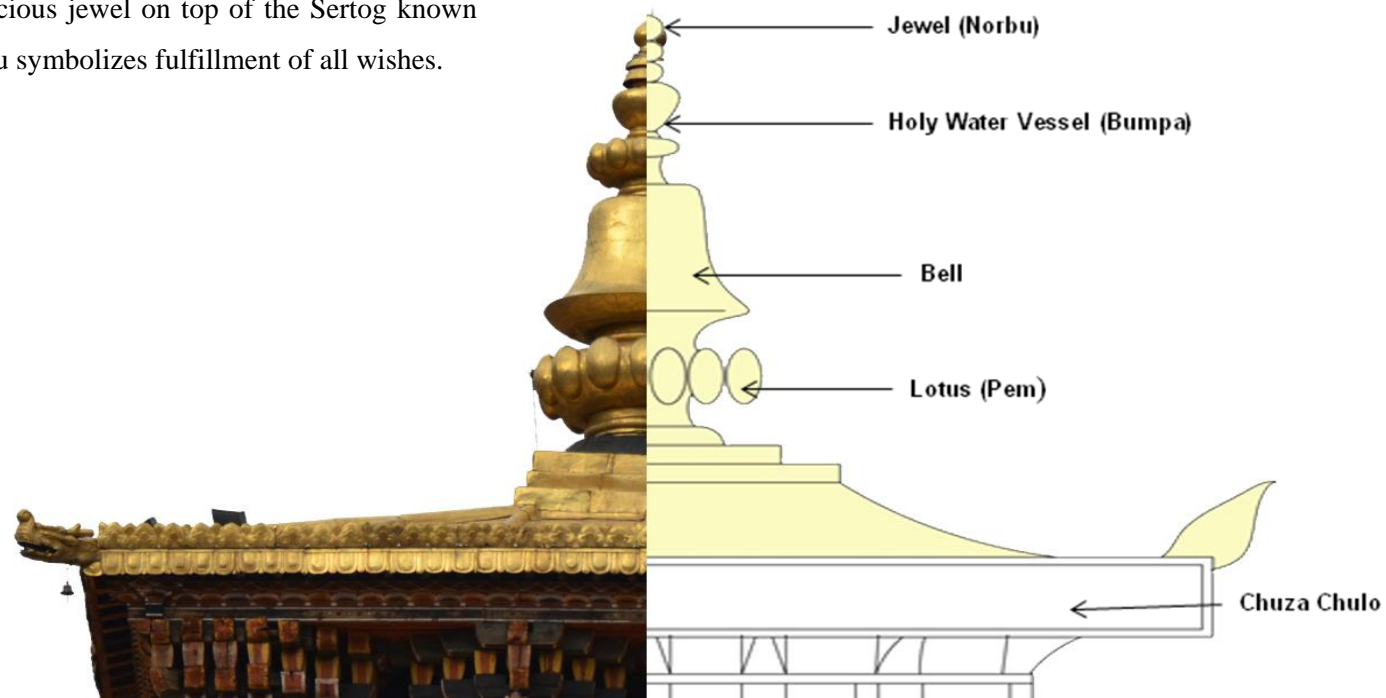

GYELTSHEN

The Gyeltshen is an element in traditional Bhutanese architecture that represents the sacred parasol of victor of compassion and good. The Gyeltshen was thus only placed over roofs of religious buildings, palaces and residences of high Buddhist Masters as a mark of sacred blessings.

The Gyeltshen is constructed out of brass or copper which is often plated in gold with carvings of sacred iconography and prayers.

The Gyeltshen is usually placed directly over all types of roof including Jabzhi roof and Jamthok roof. Unlike the Sertog roof, the roof for Gyeltshen is not decorated with Chuza Chulo or Chunju Patra.

The Gyeltshen is often also placed over the very tall prayer flag poles known as Lhadar. In this case the Gyeltshen is made out of simple elements such as local cloth which is wrapped in a simple woven bamboo container basket.



Gyeltshen at Dodedra Lhakhang
(Picture: Dorji Yangki)

LHADHAR

The Lhadhar is a multicolored sacred flag which is placed on top of the roof of homes in Bhutan and sometimes simple village temples. The Lhadhar is said to represent the banner of the local Gods and is thus usually installed annually on top of the roof after the main annual family prayer offerings to local deities.

Elements of the Lhadhar

The Lhadhar generally consists of a white cloth with three trips of different coloured cloths stitched on to it in horizontal stripes as shown in the picture below. The three stripes of cloths were stitched in the order of the colours of the Rigsum Goem which is the family of the three main Buddhas. The Rigsum Goem are Chenrigzig, Jambayang and Chana Dorji and their colours are blue, red and yellow respectively.

Thobthang of the Lhadhar

Traditionally, according to the “Thobthang” or ‘entitlement’, the Lhadhar was also designed with the inclusion of other different decorative and symbolic elements. For example, the top of the Lhadhar is also designed with a circular disc called Khorlo and a Sword called Reldri. These were usually made out of local timber and painted by local artisans. It is also said that only the building that has volumes of the Domang and Gaytom Buddhist scriptures or only aristocrats who can sponsor a ceremonial tea offering to the monastic body were entitled to have the Reldri and Khorlo. The other families were entitled to install the simple Lhadhar without Reldri and Khorlo.



(Picture: Barun Chettri)

MYTHICAL ANIMAL SCULPTURES

The inclusion of sculptures of mythical animals is usually found on the walls of important religious structures and palaces.

These are installed mainly to provide protection from negative energy and spirits and also to symbolize the sacred and high ranking significance of the structure.

The most common mythical figures include the Singye Karm (the white snow lion), and the Jachung. The sculptures are sometimes carved out of wood or made in clay.

The Mythical figures are usually embedded in the wall to form the Gyetsa element which also structurally provide support to Rabsel, or balconies.





**EXAMPLES OF
SCULPTURES OF
MYTHICAL ANIMALS:**

(Trashichodzong; Semtokha
Dzong and Gantey Goenpa)

(Pictures: Dorji Yangki)

PROPORTION IN TRADITIONAL BHUTANESE ARCHITECTURE

BOGH AND PHANA

The size of the Bogh is governed by the size of Cham which in turn is same as that of the sizes of Lenbhu and Dhung. Width to height proportion is generally x : ($x + 25\text{mm}$).

The length of Bogh cantilever is also x . The spacing between the Boghs ranges from $x + 25\text{mm}$ to 2 times x . In dwellings the length of x ranges from 125mm to 150mm while it is much bigger in Dzongs, generally equaling 175mm.

The Phana is also made from the same timber section as Cham. However, when placed in position, Phana appears much taller than Bogh as it is placed on the diagonal face.

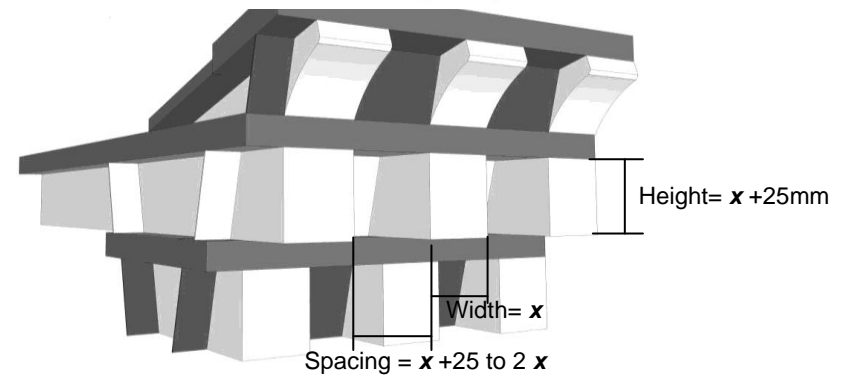
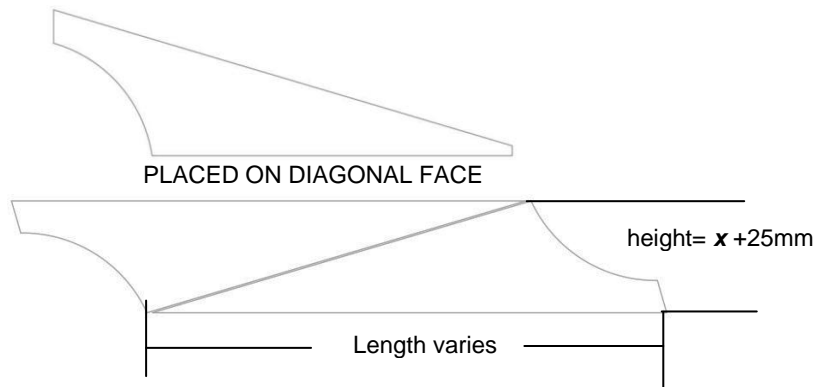
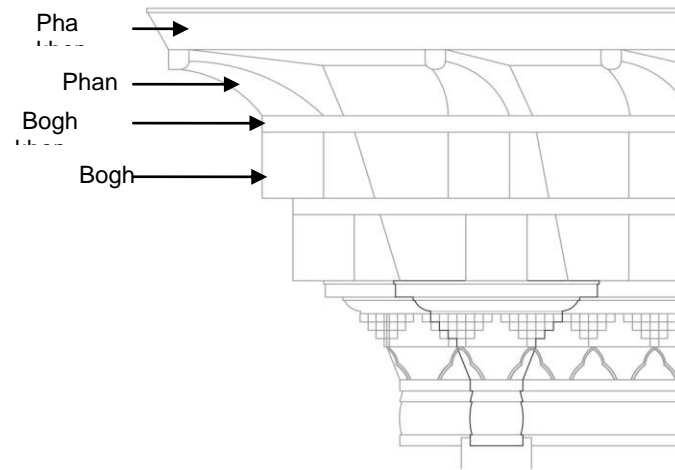

DETAILS OF BOGH AND PHANA
(Drawing: Tshering Phuntsho)

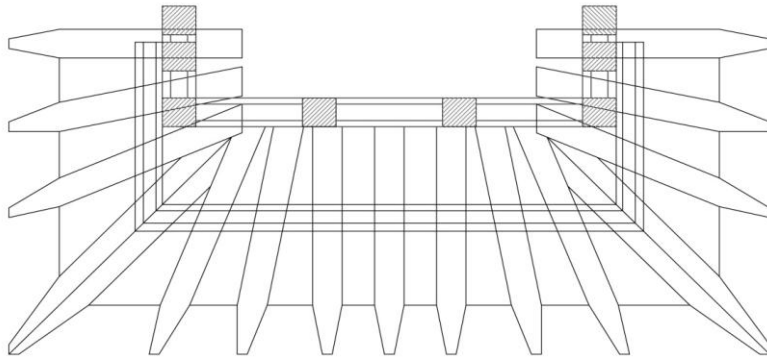

Phana layout on Rabsel

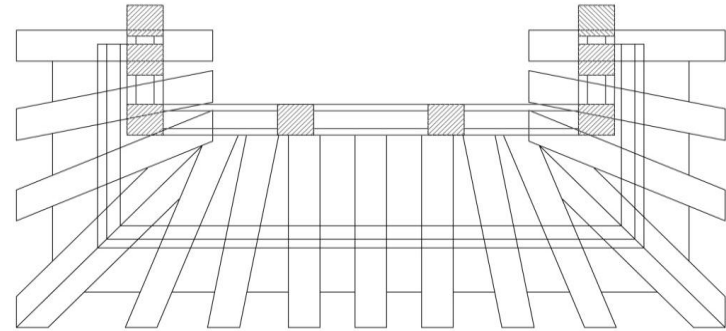

Cham layout on Rabsel

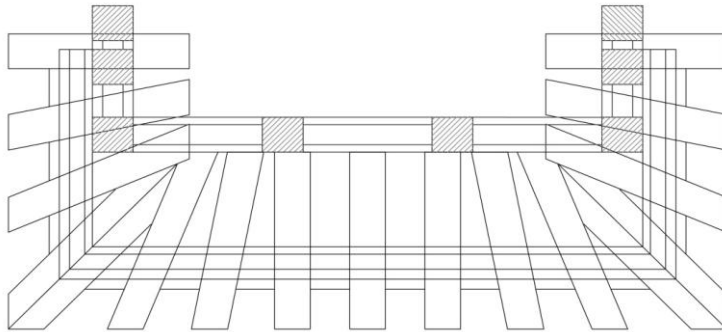

Bogh layout on Rabsel

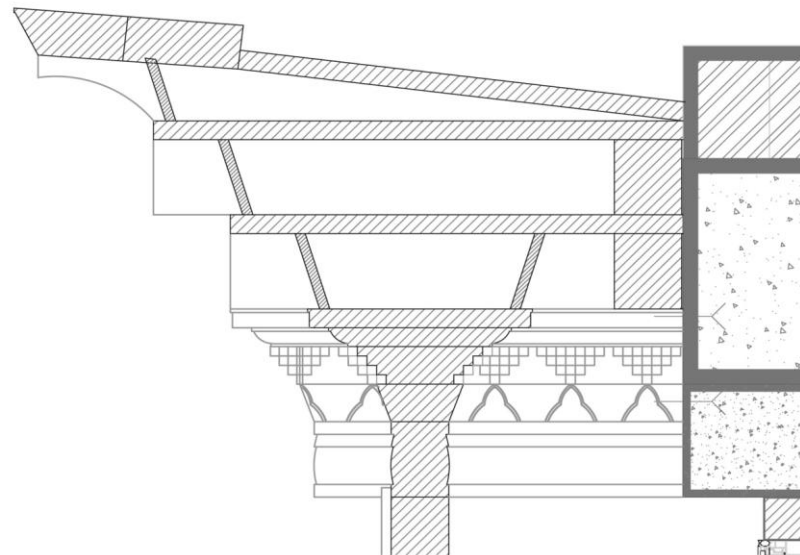

Sectional Elevation of Bogh and Phana

TYPICAL PLAN AND SECTIONAL ELEVATION OF BOGH AND PHANA

(Drawing: Tshering Phuntsho)

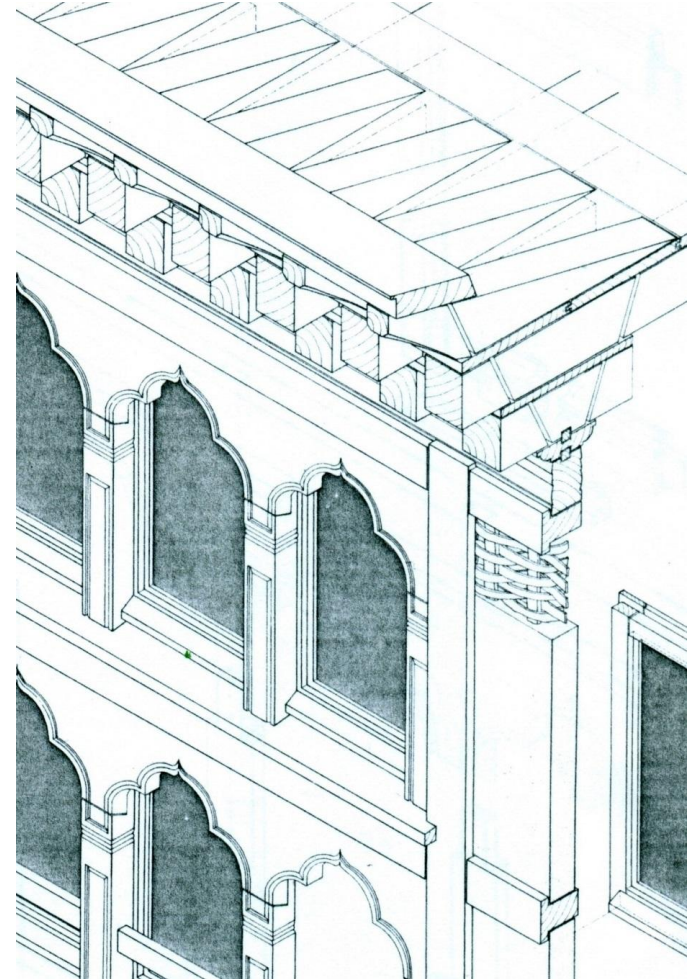

EXAMPLES BOGH AND PHANA IN DIFFERENT BUILDINGS

SECTIONAL VIEW OF BOGH AND PHANA
(Pictures: Tshering Phuntsho)

PEM AND CHOETSE

Proportion of Pem and Choetse varies according to the size of structure and purpose and location of its usage.

If it is used with Dhung in a Rabsel, the approximate thickness ranges from 50mm to 100mm with Khangser (border) of 5mm each.

But when it is used as a decorative framing around windows, its size can be as small as 25mm with a maximum thickness of 50mm.

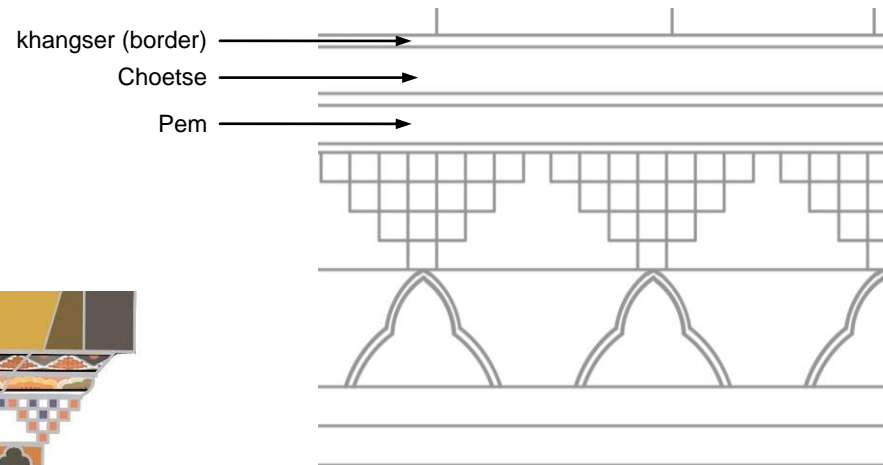

NORBU BAGUM AND NORBU HORZHU

These two elements can be carved out from one piece of wood or two different blocks of wood. In both cases the thickness ranges from 75mm to 125mm.

Scaling and division of the carvings are carried out once sizes of wood blocks are fixed. When these two elements are used together, Norbu Bagum is placed on top of Norbu Horzhu.

The face of Norbu Bagum tapers either at 45 degree or less while that of Norbu Horzhu varies between 20 and 35 degrees.

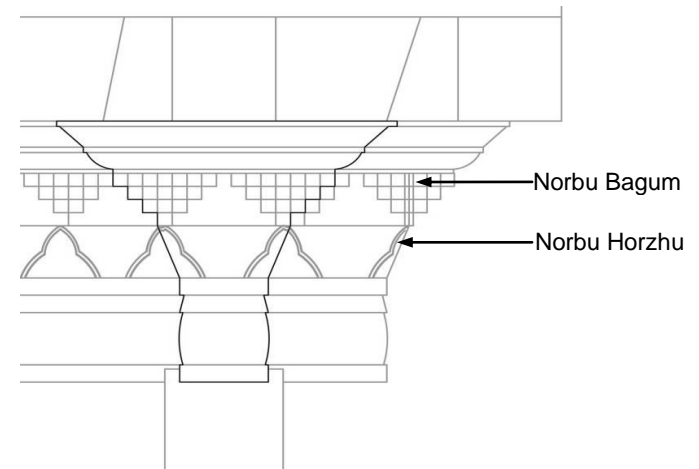
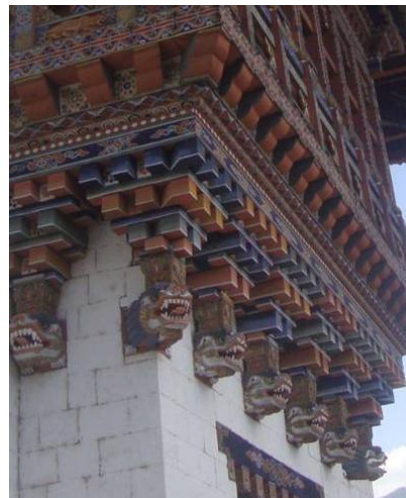

TSHECHU KHA-NYIM

The size of the Tshechu Kha-nyim is same as the Cham, mentioned under Bogh and Phana. With regard to its details, Tshechu Kha-nyim has Khangser both at the top and bottom of equal thickness.

The remaining mid-section is divided into two equal parts for creation of the two curved faces.

It is also possible to create a much simpler Gay-Langna with just one curved face. In either case the projection of the Tshechu Kha-nyim/ Langna is equal to $x + 25\text{mm}$.

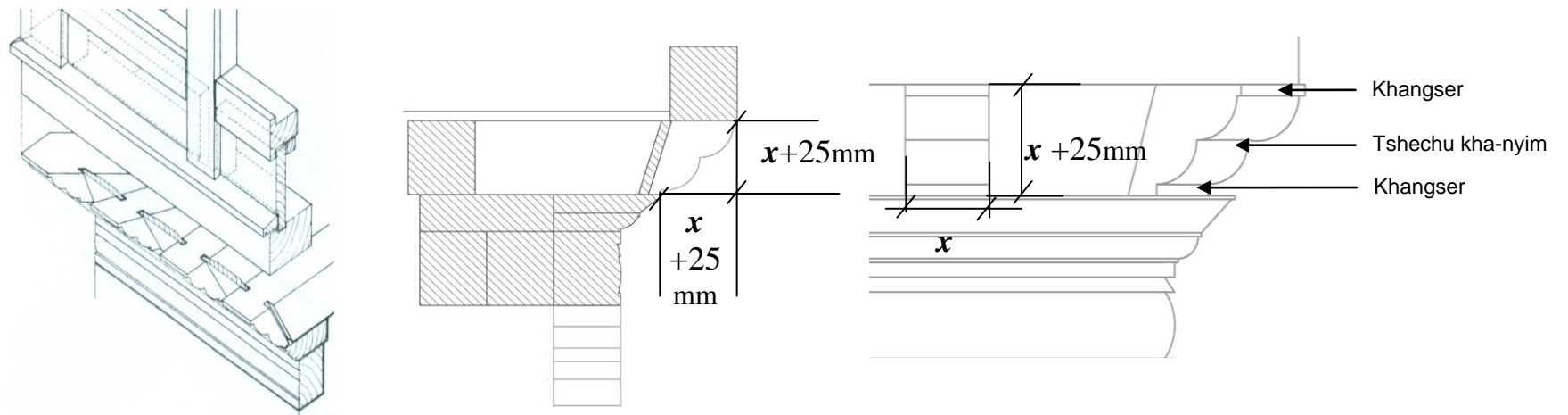

(Drawing: Tshering Phuntsho)

RABSEL

In a Rabsel, the structural member with the largest sectional area is the Zumbhu. The second largest members are the Barbhu, also known as the Lenbhu and the Budhen. The smallest member is the Jaka. The size of the Budhen is determined by the thickness of the Kachung.

If the thickness of the Kachung is x , it requires a minimum setback of 25mm each in front and at the back, 25mm for shutter groove and another 25mm set back.

The size of the Budhen is $100\text{mm} + x$, the thickness of the kachung. Therefore, if the thickness of the kachung is 75mm, the size of the Budhen and the Barbhu/Lenbhu would be 150mm X 175mm. It could also be 175mm X 175mm while the size of the Zumbhu would be 175mmx175mm.

Other members of the Rabsel are governed by the size and proportion of the Jaka. The Jaka has a square section which is derived by subtracting the width of the shutter groove and the inner set back, of 25mm, from the Budhen/ Lenbhu. This comes to 125mm X 125mm if size of the Budhen or the Lenbhu is 150mm X 175mm or 175mm X 175mm. It can also be worked out as $25\text{mm} + x + 25\text{mm}$ where x is the thickness of the Kachung.

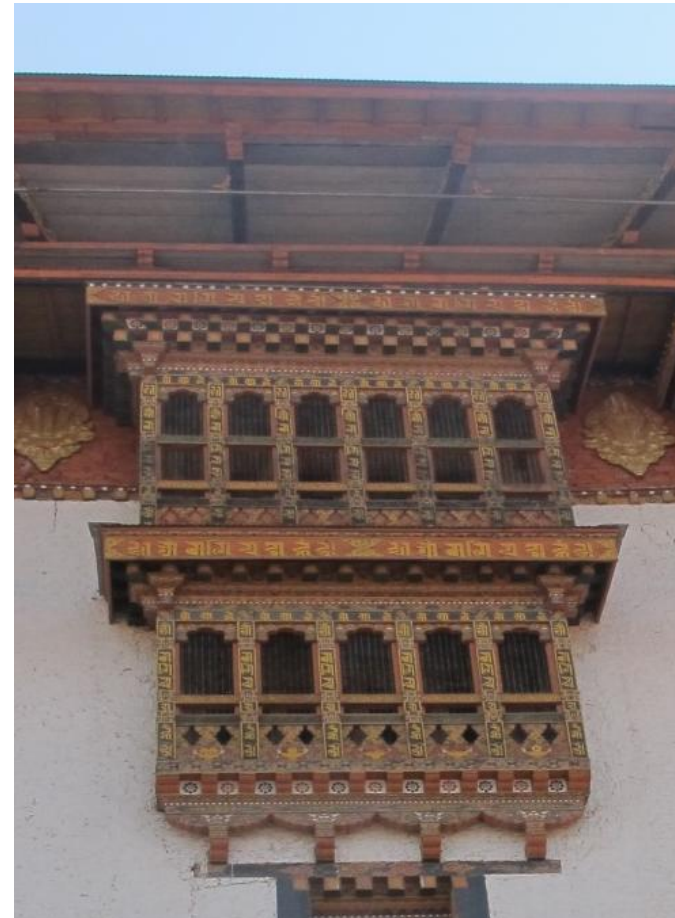

The depths of Lenbhu, Gyenthi, Keyra-Gentho and Yathoe must equal the width of Budhen and the face width will be equal to width of Jaka.

Taking the above example where the thickness of the Kachung is 75mm, Lenbhu, Gyenthi, Keyra-Gentho and Yathoe size would be 125mm X 175mm, Jaka size would be 125mm X 125mm.

Theoretically, the size of the Dhung should be same as Lenbhu but in practice its width is slightly increased for better proportional aesthetics. Therefore, instead of 125mm X 175mm, it would be 150mm X 175mm.

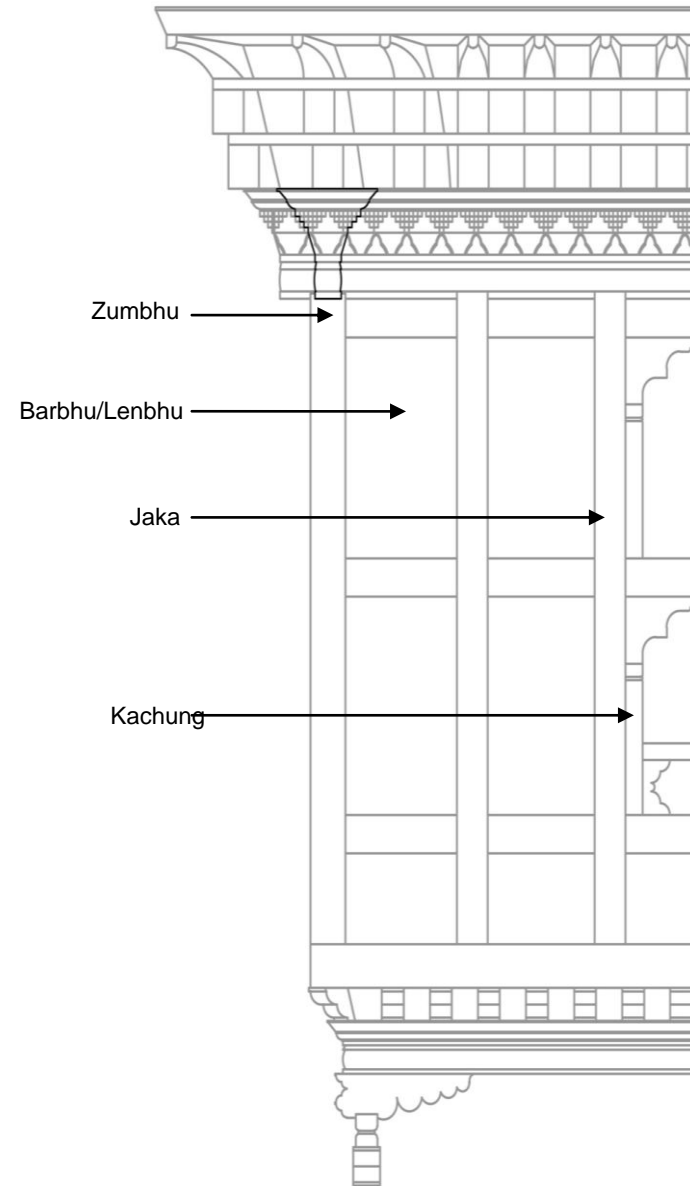

(Drawing: Tshering Phuntsho)

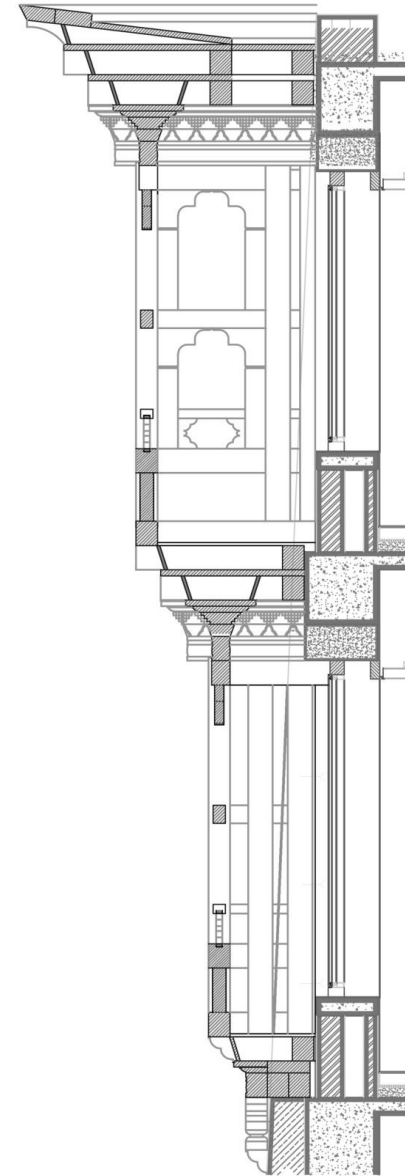
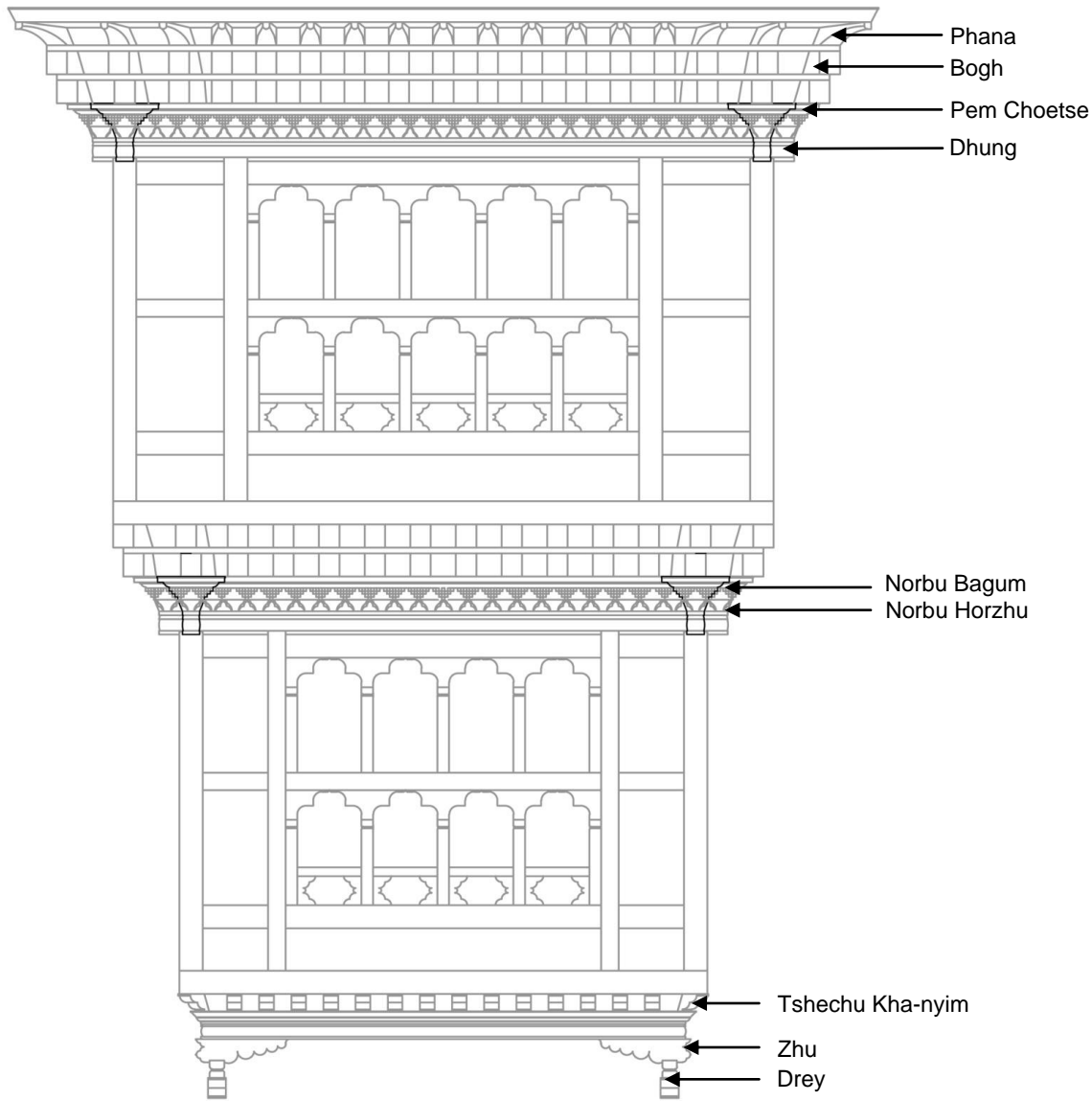

(Drawing: Tshering Phuntsho)



EXAMPLES OF RABSEL

SECTION TWO

CONTEMPORARY ARCHITECTURAL GUIDELINES

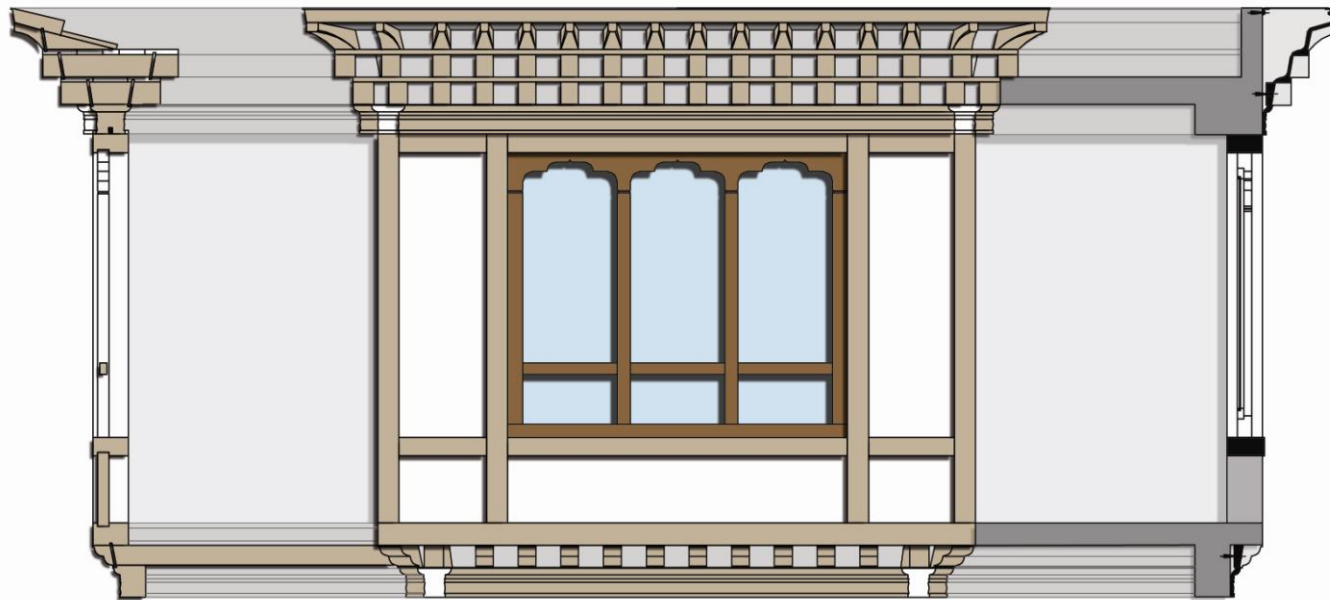

SECTION TWO

CONTEMPORARY ARCHITECTURAL GUIDELINES

As mentioned in the scope and limitations, this section will solely focus on guidelines pertaining to the facade of contemporary buildings using non-traditional materials. All information regarding traditional Thobthang, Thigtshed and Khung Dang Goepa has been covered in Section I.

The focus of this section shall be on architectural elements that regulate the facade of buildings using new construction techniques and contemporary materials.

The various traditional Architectural elements/components covered in this section are:

1. Kachens
2. Payab windows
3. Rabsel windows
4. Cornices (Bogh, Cham, Phana, etc)
5. Roofs

Recommended guidelines for application of these traditional elements shall be as follows:



EXAMPLES OF CONTEMPORARY BUILDINGS

(Pictures: Dago Retty)

2.1 KACHENS

2.1.1. Though the Kachen size in RCC buildings is governed by the structural requirements, the recommended sizes for RCC Kachen proportionate to the heights shall be as follows:

1. For height 3.5 – 4 m; recommended size 400 – 500 mm
2. For heights greater than 4 m; minimum size 500 mm as illustrated in Fig 2.1.a, 2.1.b and 2.1.c

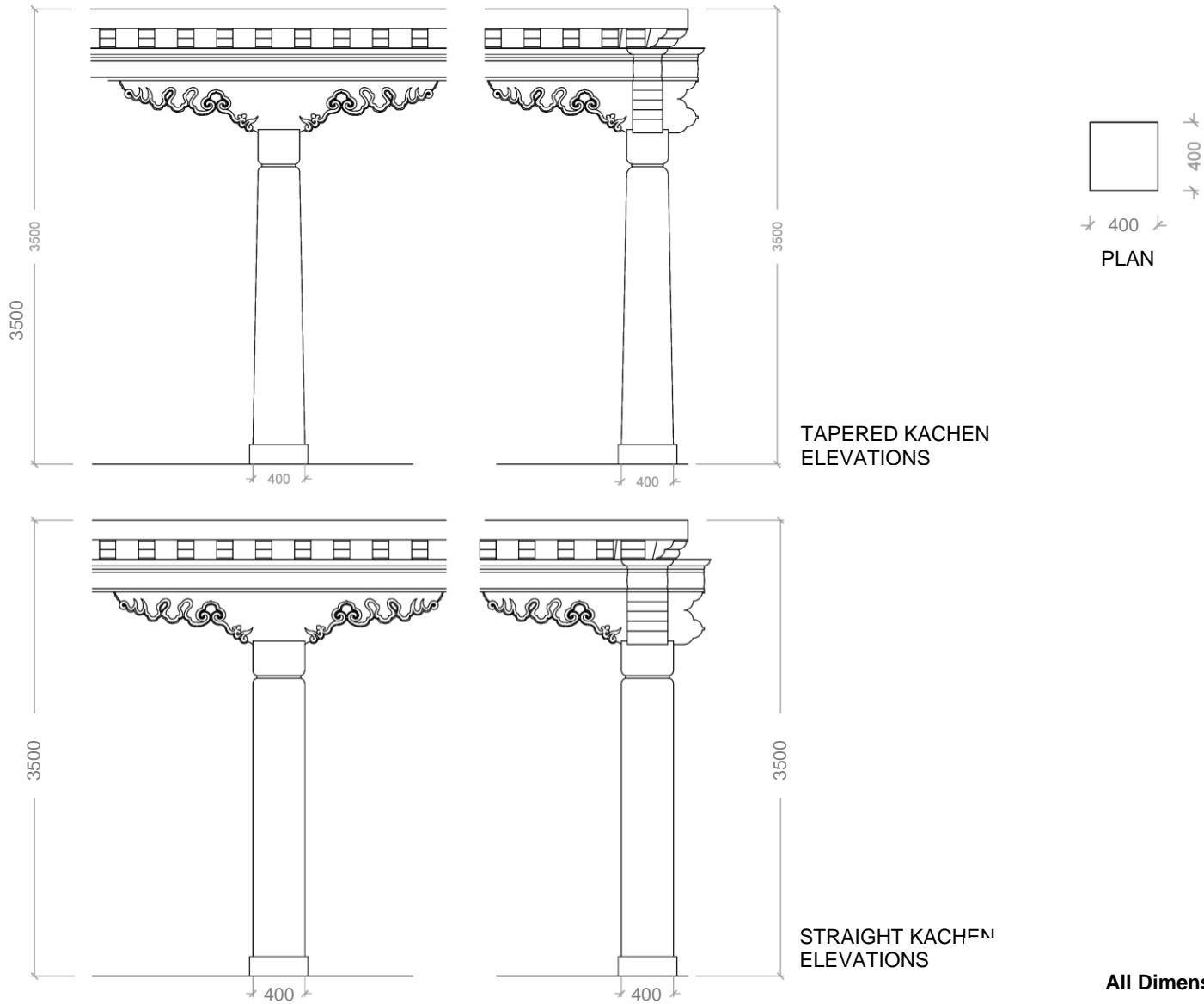

TAPERED KACHEN ELEVATIONS

STRAIGHT KACHEN ELEVATIONS

All Dimensions are in mm.

Fig.2.1.a. 400mm THICK KACHEN FOR 3500mm FLOOR HEIGHT
(Drawing: Singav Daduel)

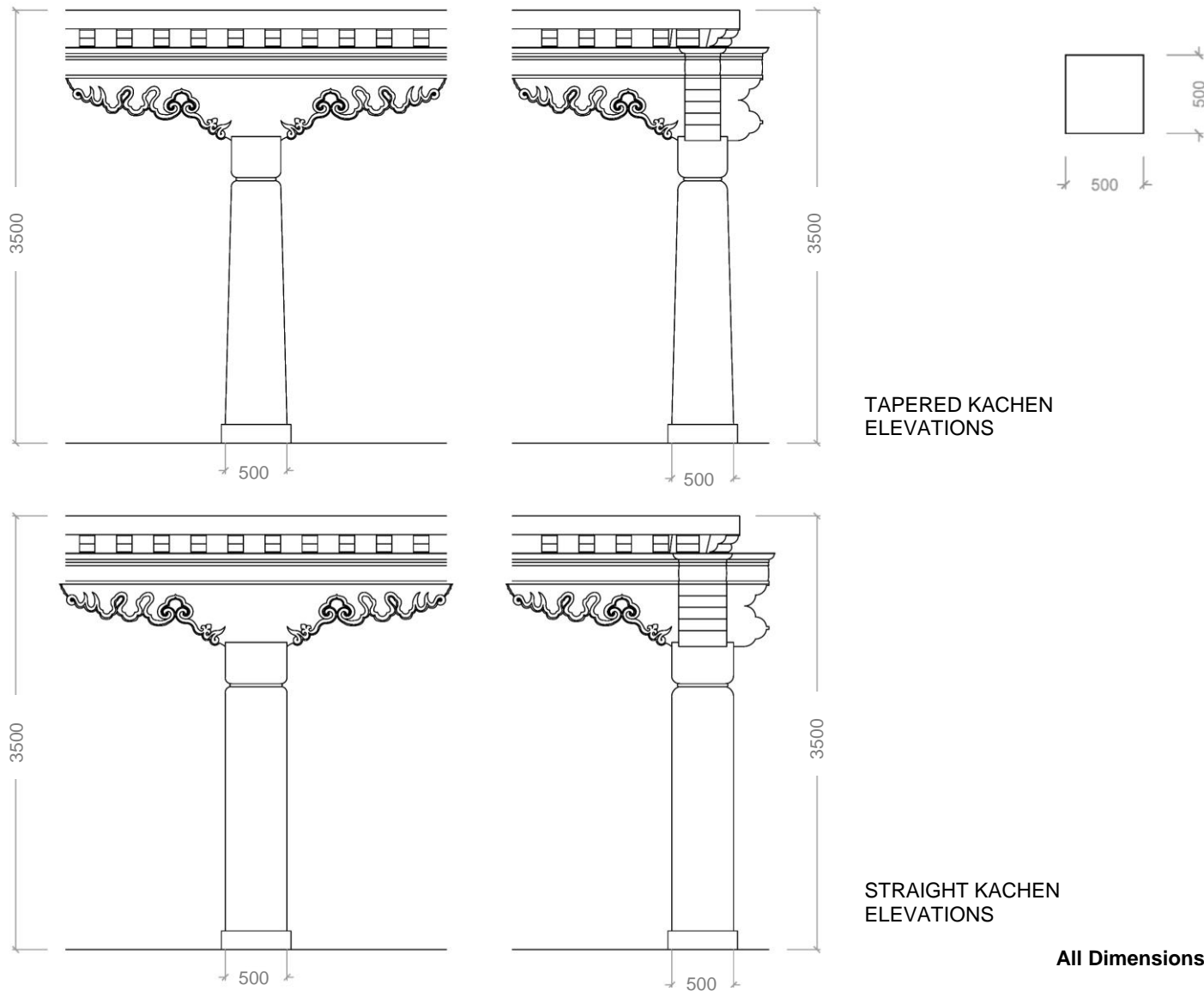

TAPERED KACHEN
ELEVATIONS

STRAIGHT KACHEN
ELEVATIONS

All Dimensions are in mm

**Fig.2.1.a. 500mm THICK KACHEN FOR
3500mm FLOOR HEIGHT**

(Drawing: Singay Daduel)

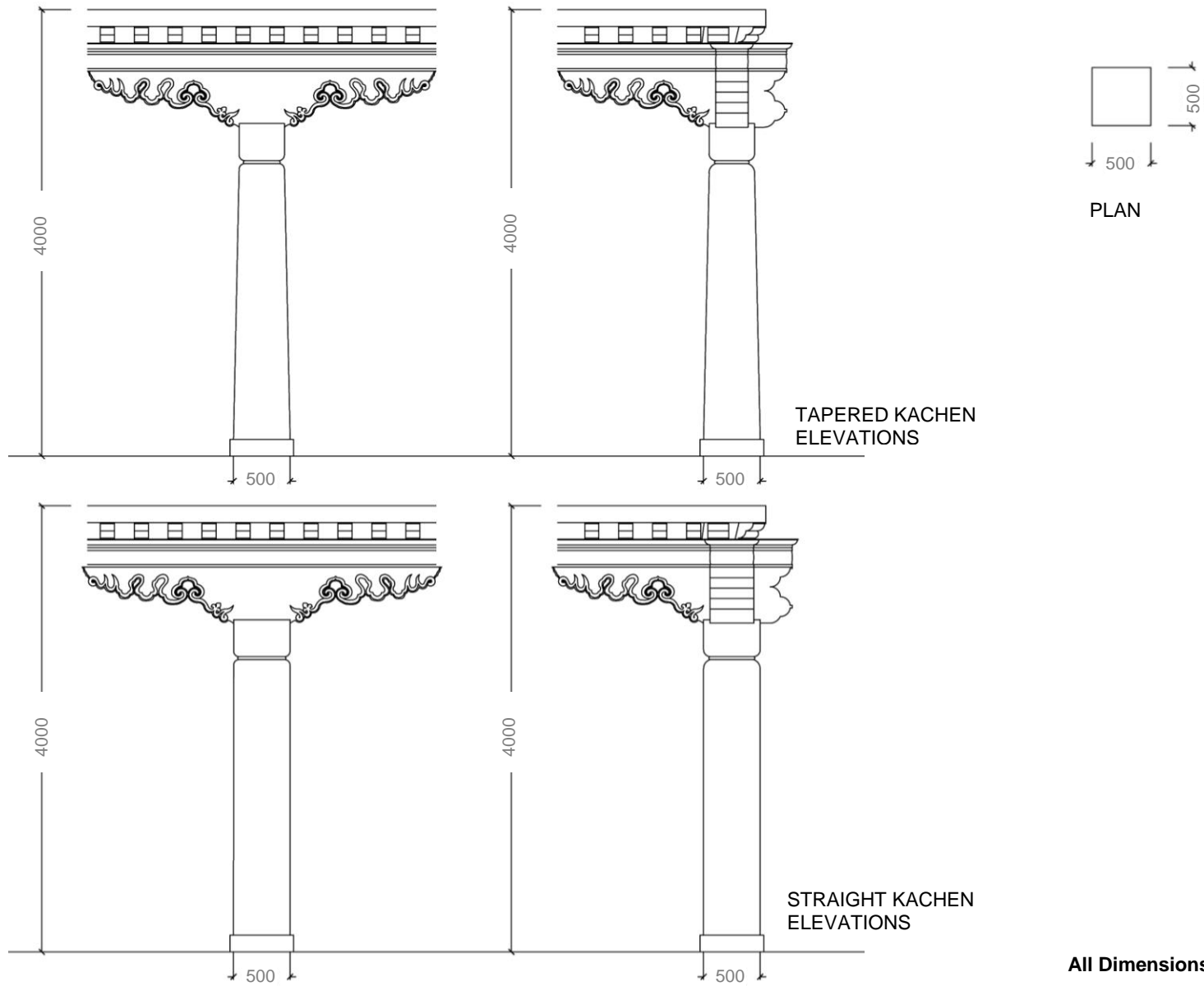

All Dimensions are in mm
Fig.2.1.b. 500mmTHICK KACHEN
FOR 4000 mmFLOOR HEIGHT
 (Drawing: Singay Daduel)

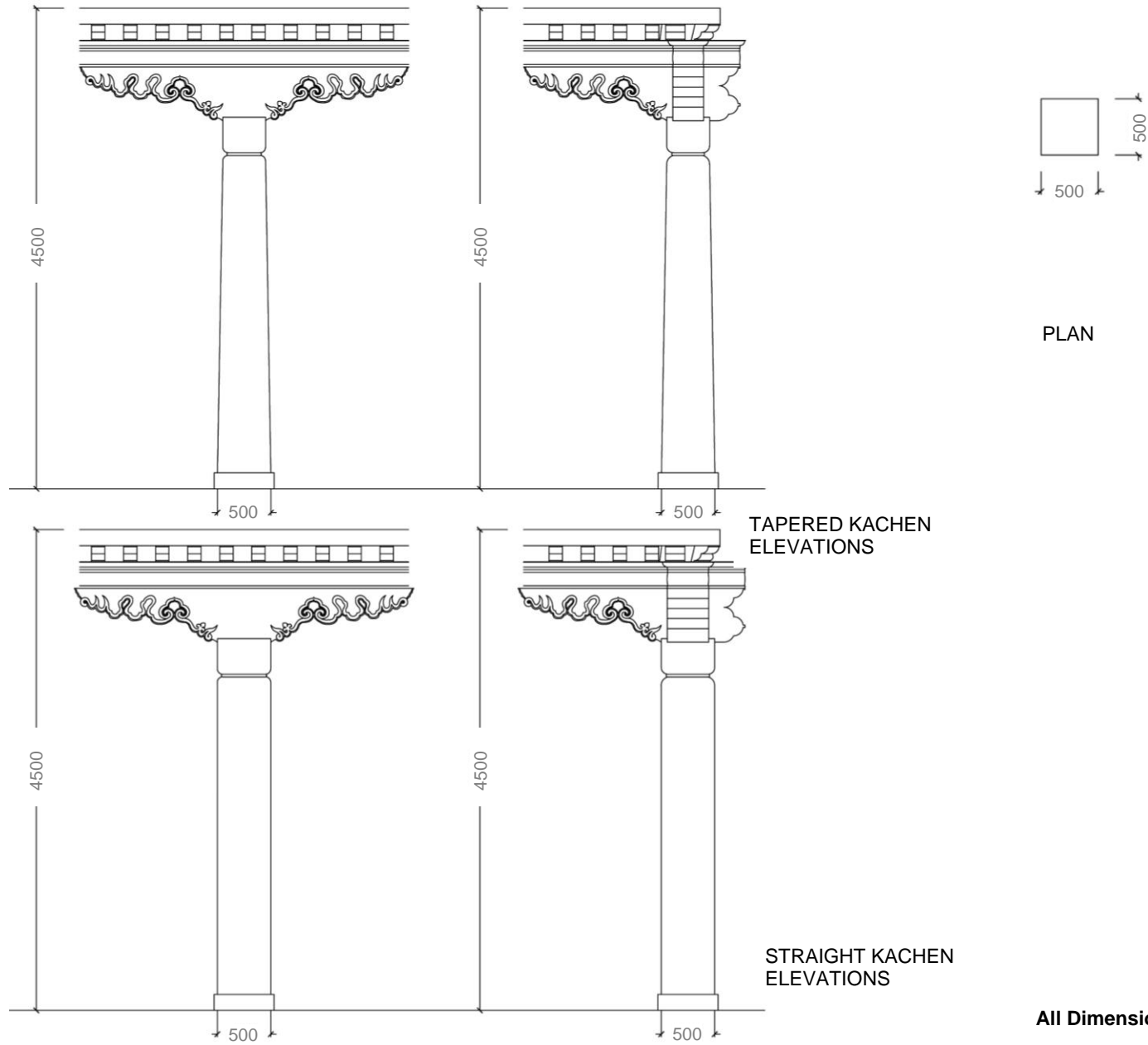

All Dimensions are in mm

**Fig.2.1.b. 500mm THICK KACHEN
FOR 4500mm FLOOR HEIGHT**
(Drawing: Singay Daduel)

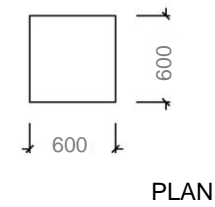
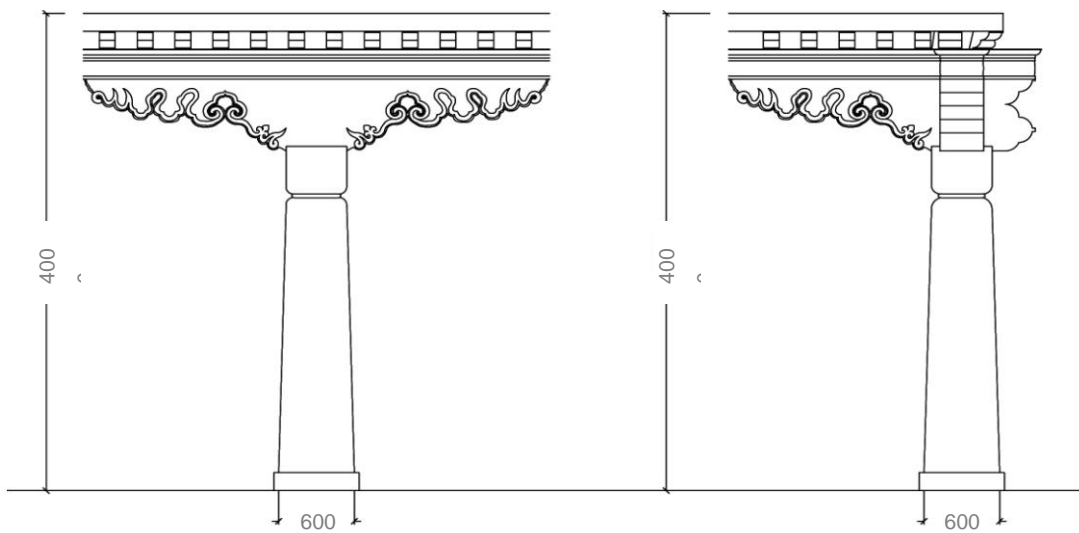

TAPERED KACHEN ELEVATIONS

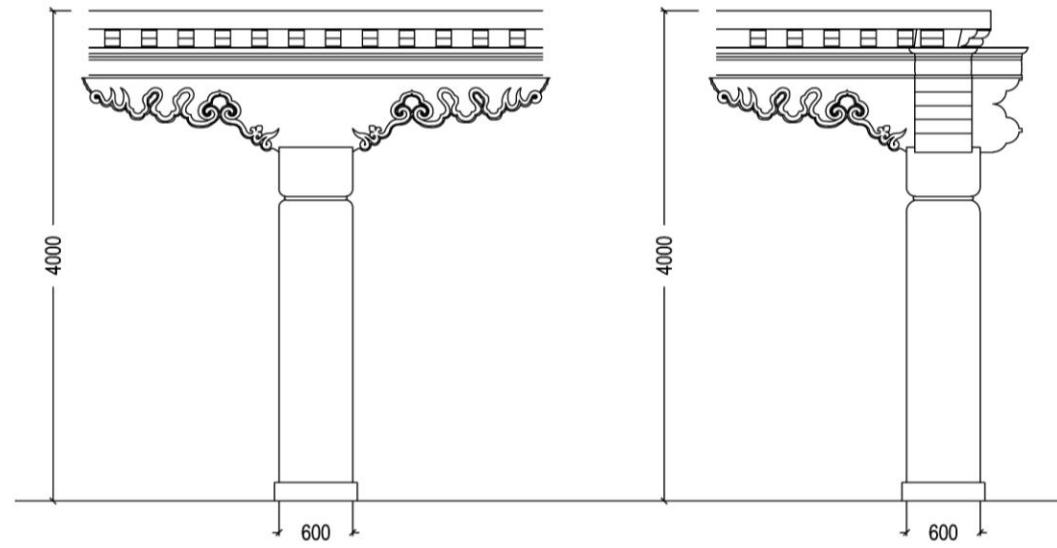

STRAIGHT KACHEN ELEVATIONS

All Dimensions are in mm

Fig.2.1.c. 600mm THICK KACHEN FOR 4000mm FLOOR HEIGHT
(Drawing: Singay Daduel)

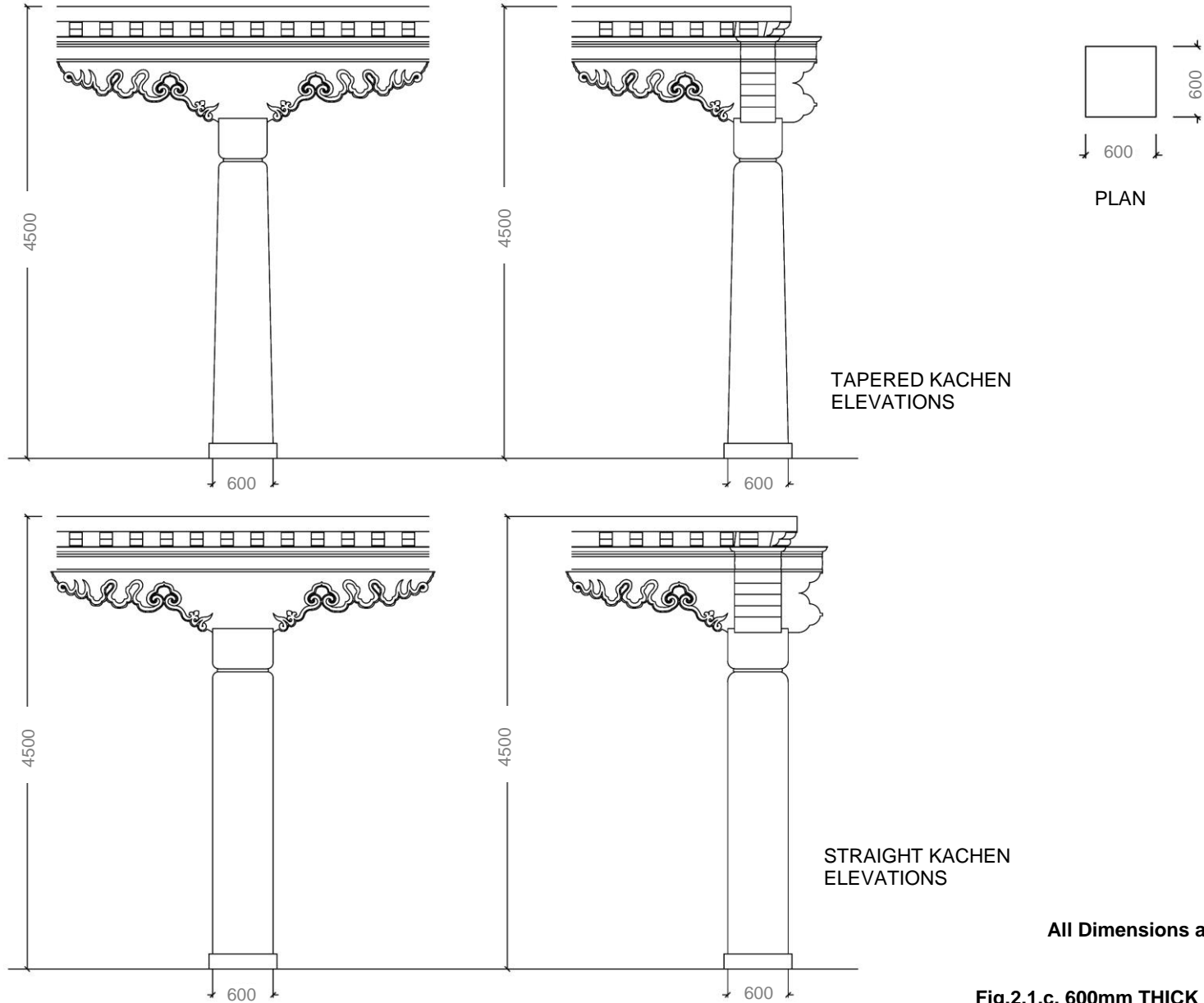

All Dimensions are in mm

**Fig.2.1.c. 600mm THICK KACHEN
FOR 4500mm FLOOR HEIGHT**
(Drawing: Singay Daduel)

2.1.2. The different Kachens which may be used are as illustrated in Fig. 2.1.d, 2.1.e. and 2.1.f.

However, other shapes which can be used are not limited to the ones illustrated.

2.1.3. Types of Zhu which may be used but not limited to are as illustrated in Fig.2.1.g

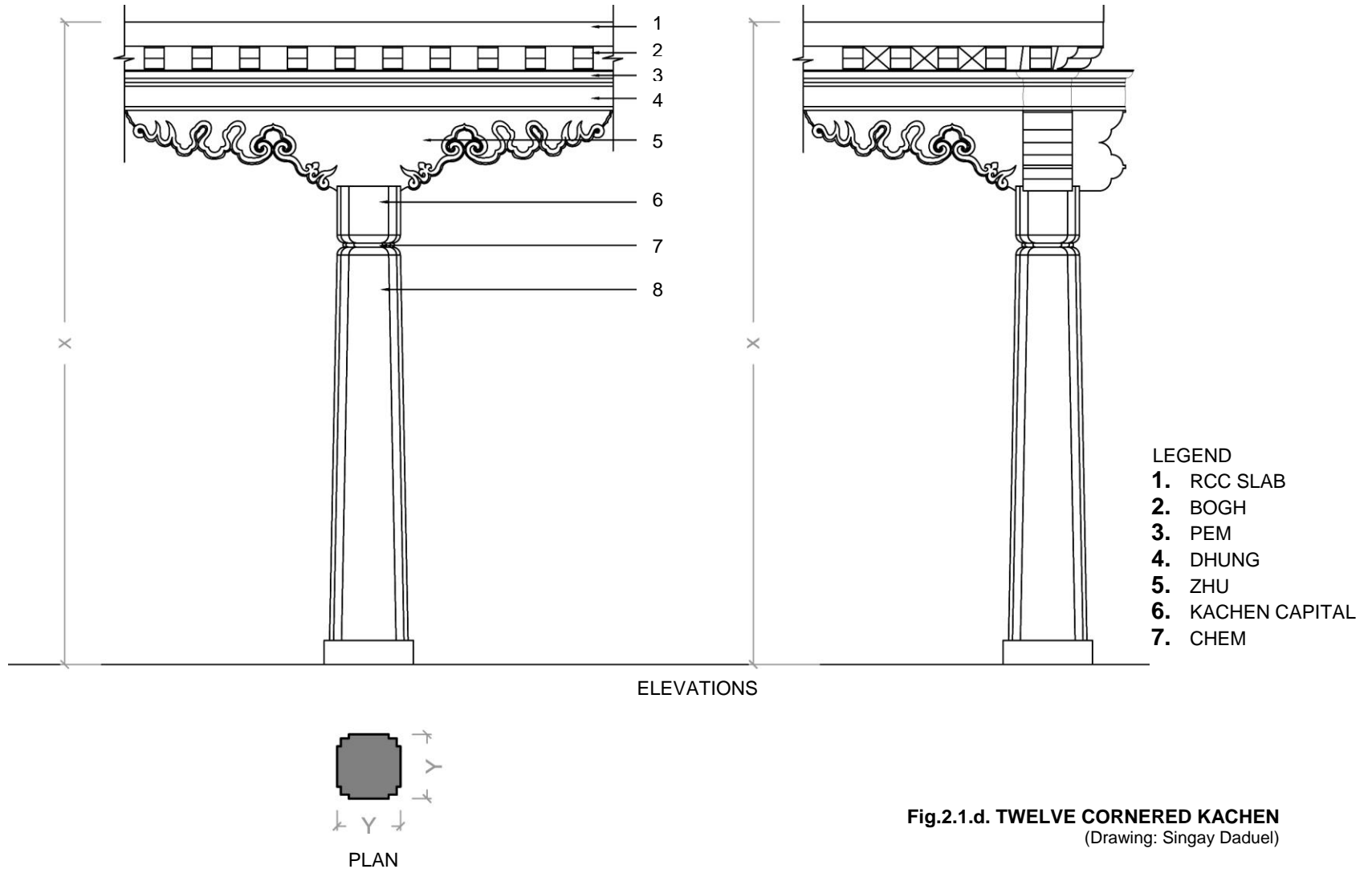

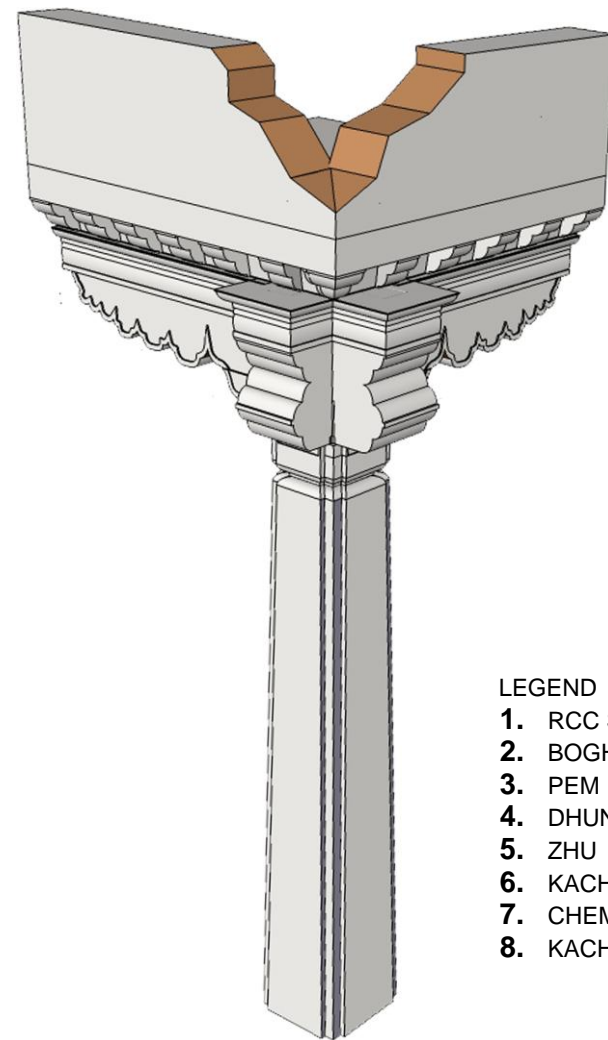
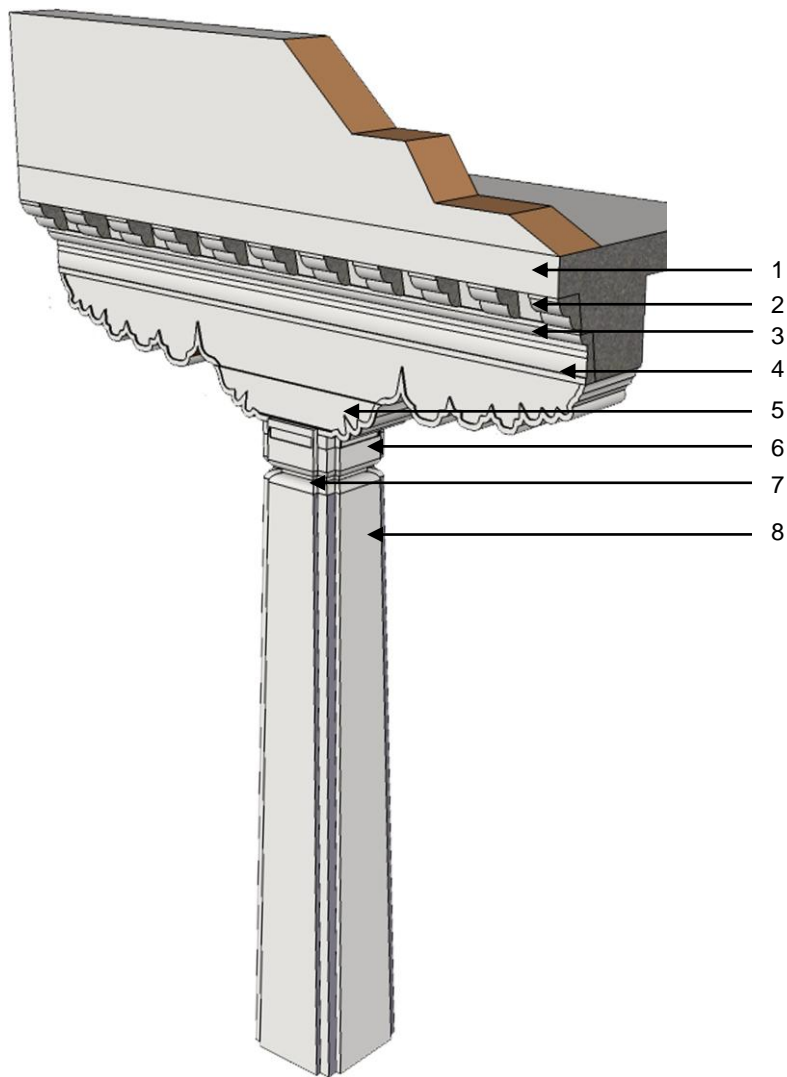

VIEWS

- LEGEND
- 1. RCC SLAB
 - 2. BOGH
 - 3. PEM
 - 4. DHUNG
 - 5. ZHU
 - 6. KACHEN CAPITAL
 - 7. CHEM
 - 8. KACHEN

Fig.2.1.d. TWELVE CORNERED KACHEN
 (Drawing: Singay Daduel)

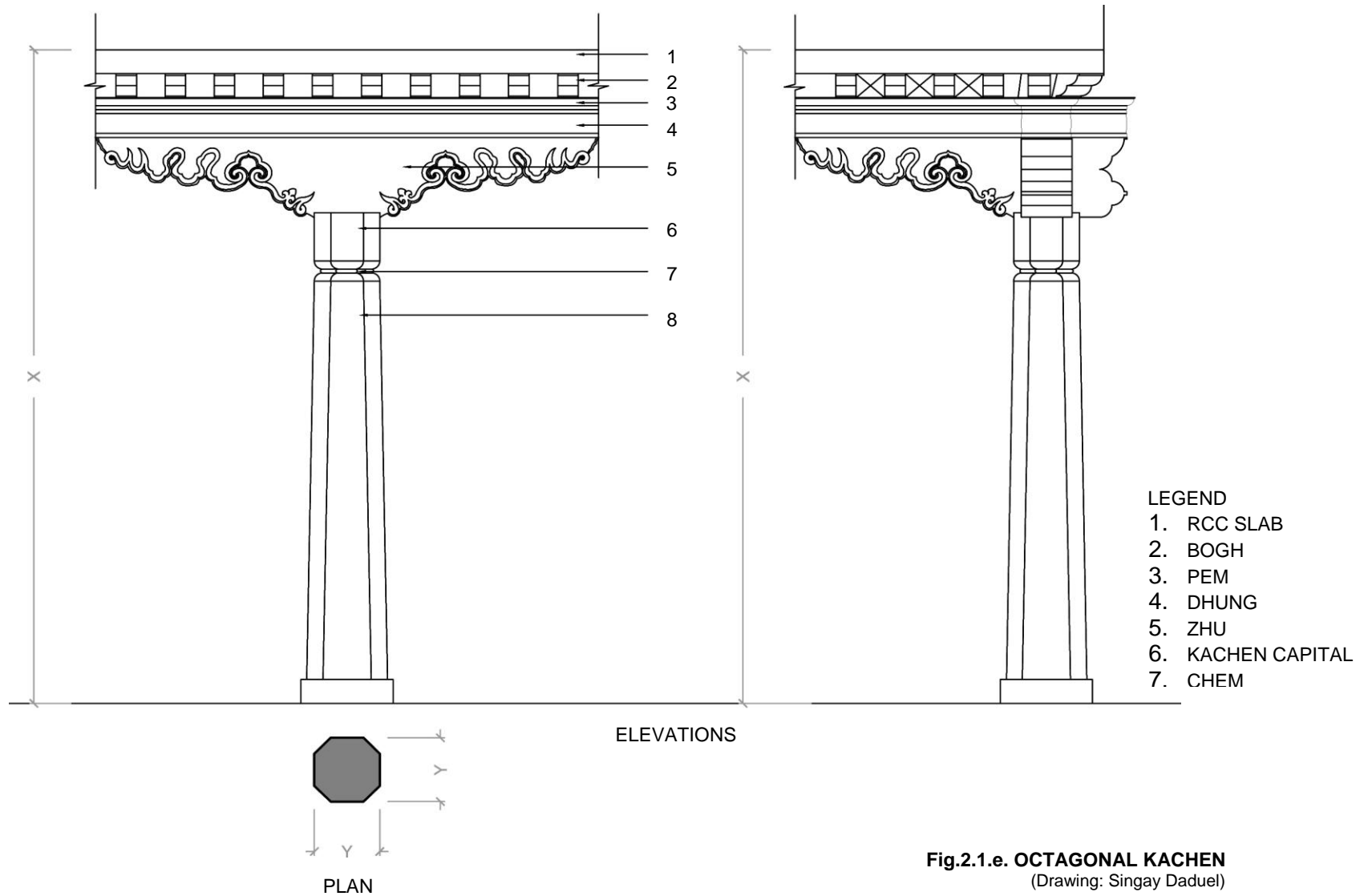

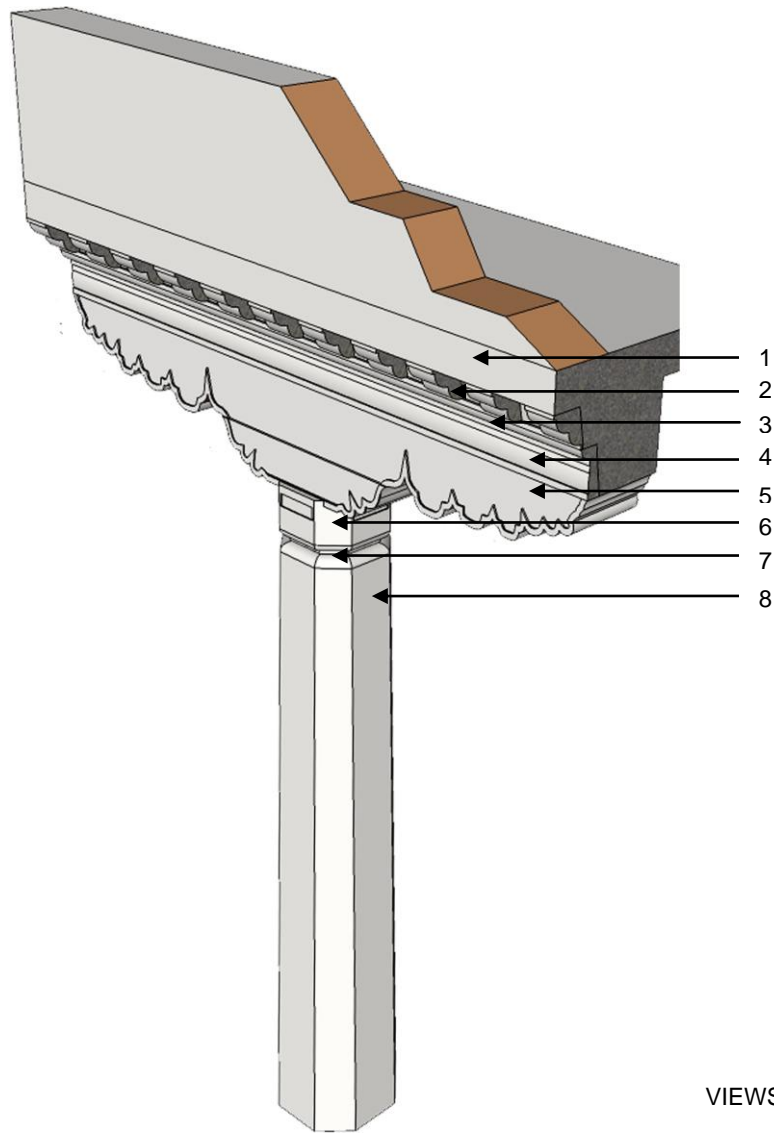

VIEWS

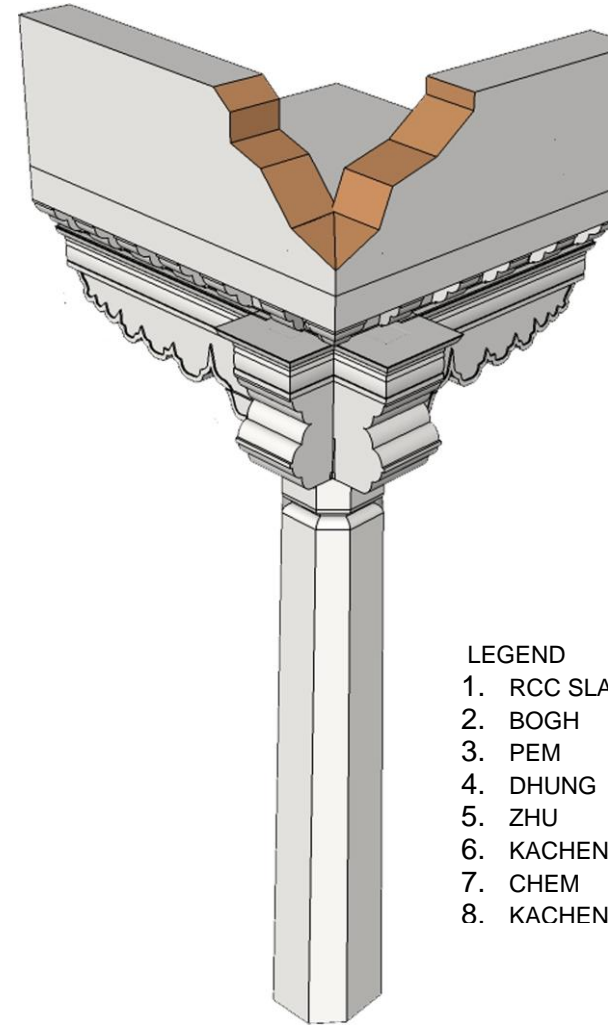

- LEGEND
1. RCC SLAB
 2. BOGH
 3. PEM
 4. DHUNG
 5. ZHU
 6. KACHEN CAPITAL
 7. CHEM
 8. KACHEN

Fig.2.1.e. OCTAGONAL KACHEN
(Drawing: Singay Daduel)

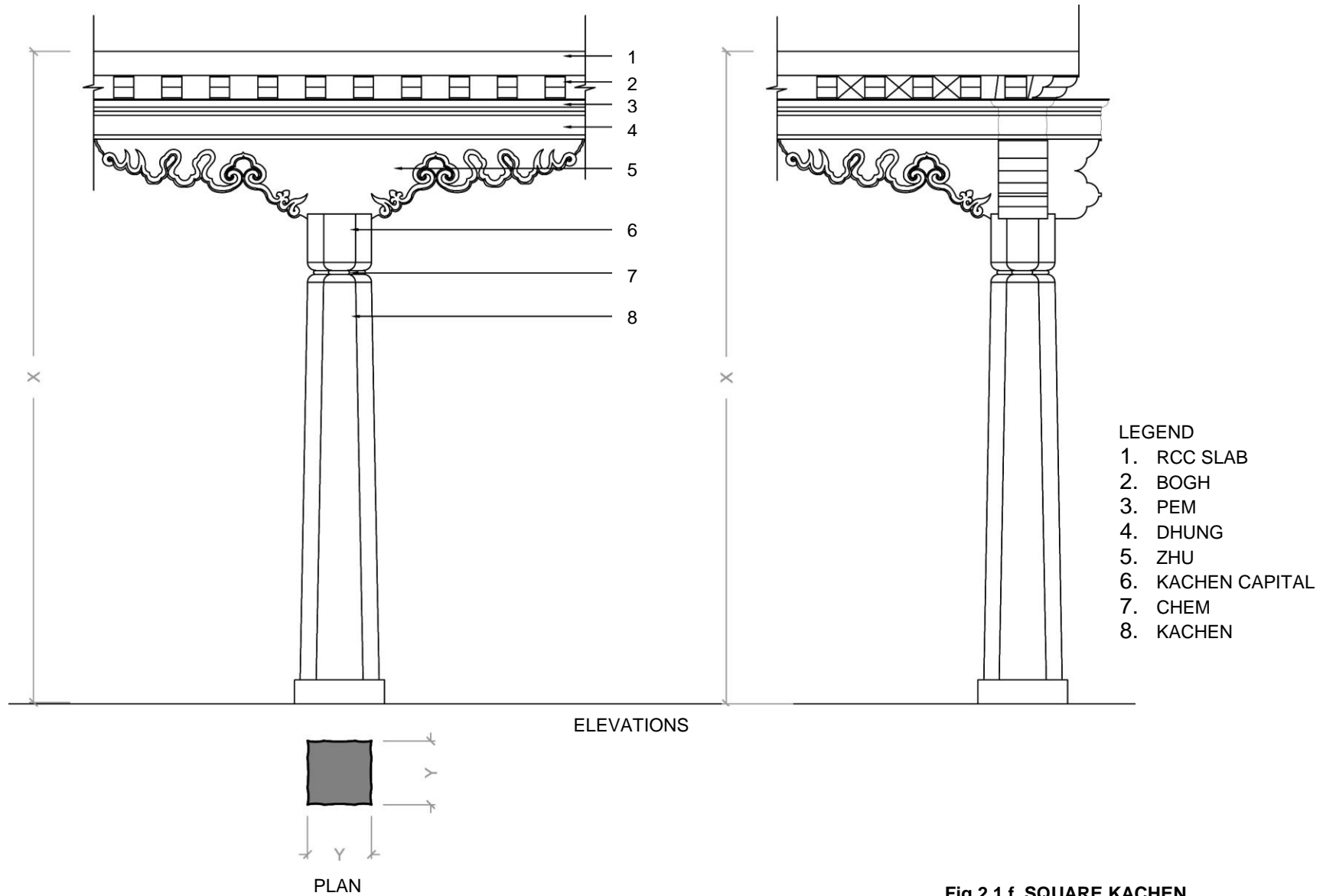
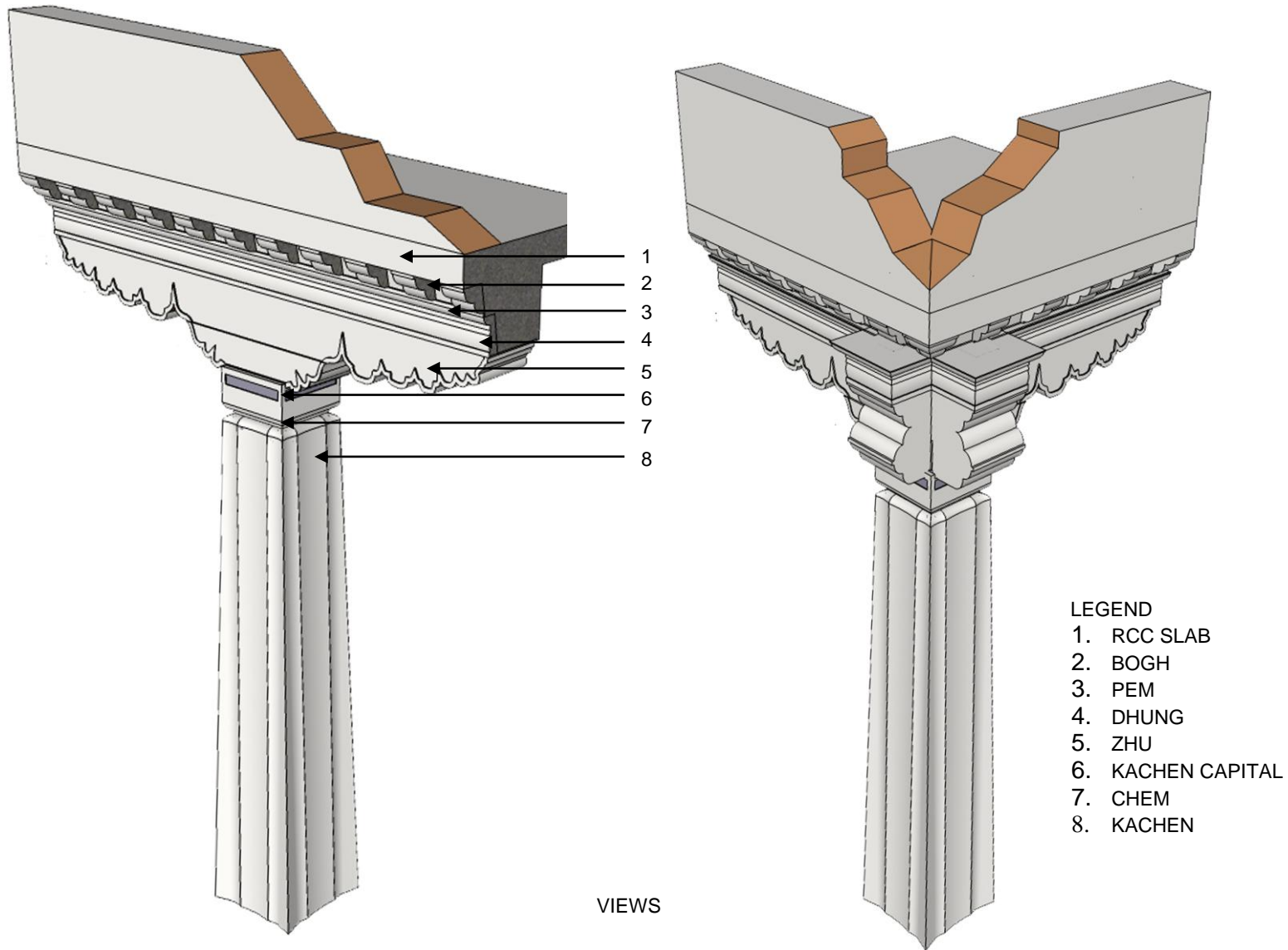

Fig.2.1.f. SQUARE KACHEN
 (Drawing: Singay Daduel)



VIEWS

- LEGEND
- 1. RCC SLAB
 - 2. BOGH
 - 3. PEM
 - 4. DHUNG
 - 5. ZHU
 - 6. KACHEN CAPITAL
 - 7. CHEM
 - 8. KACHEN

Fig.2.1.f. SQUARE KACHEN
(Drawing: Singay Daduel)

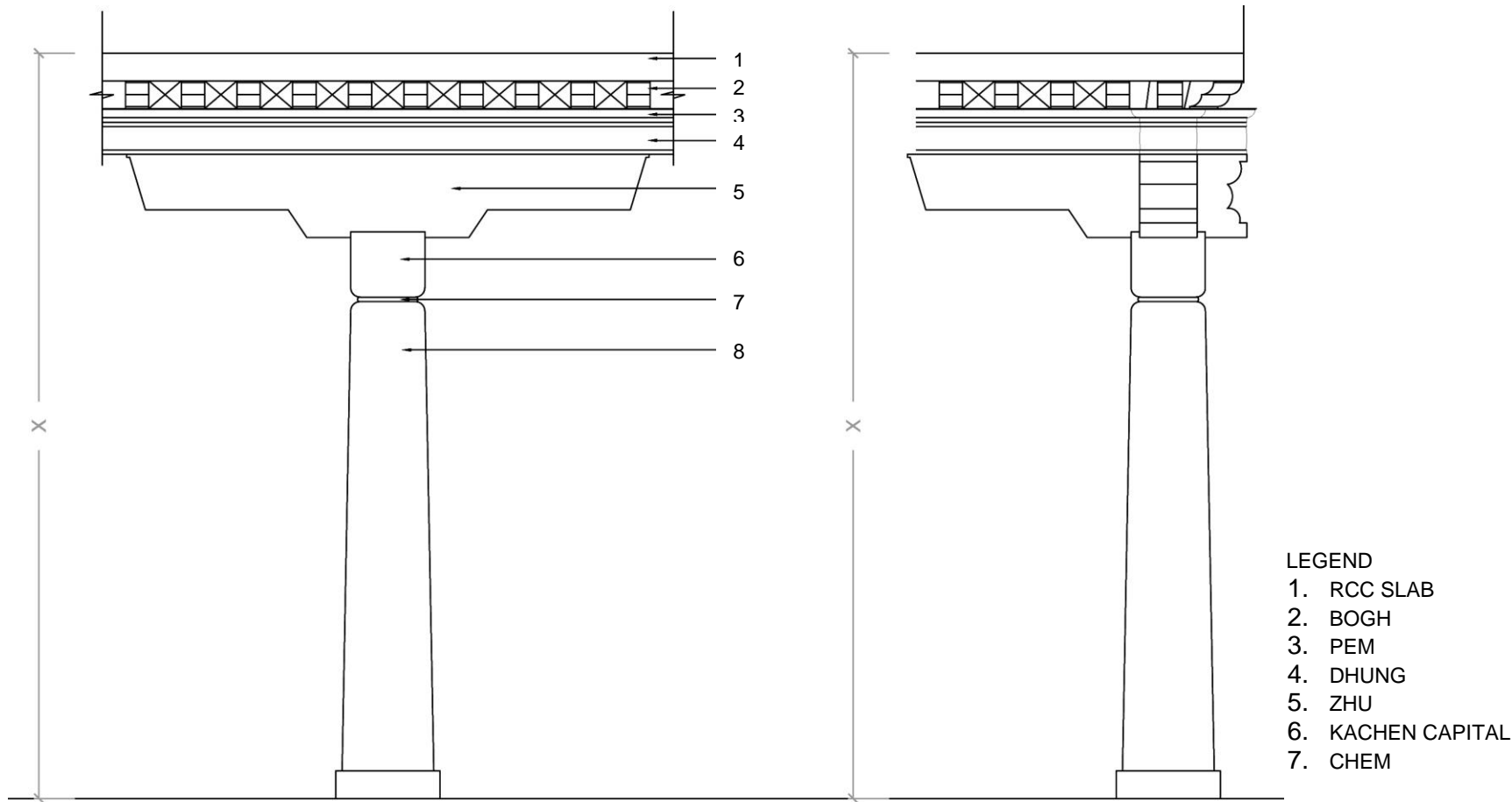

ELEVATIONS

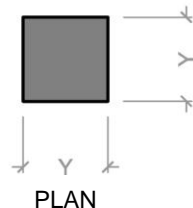

PLAN

Fig.2.1.g. KACHEN WITH SIMPLIFIED ZHU
(Drawing: Singay Daduel)

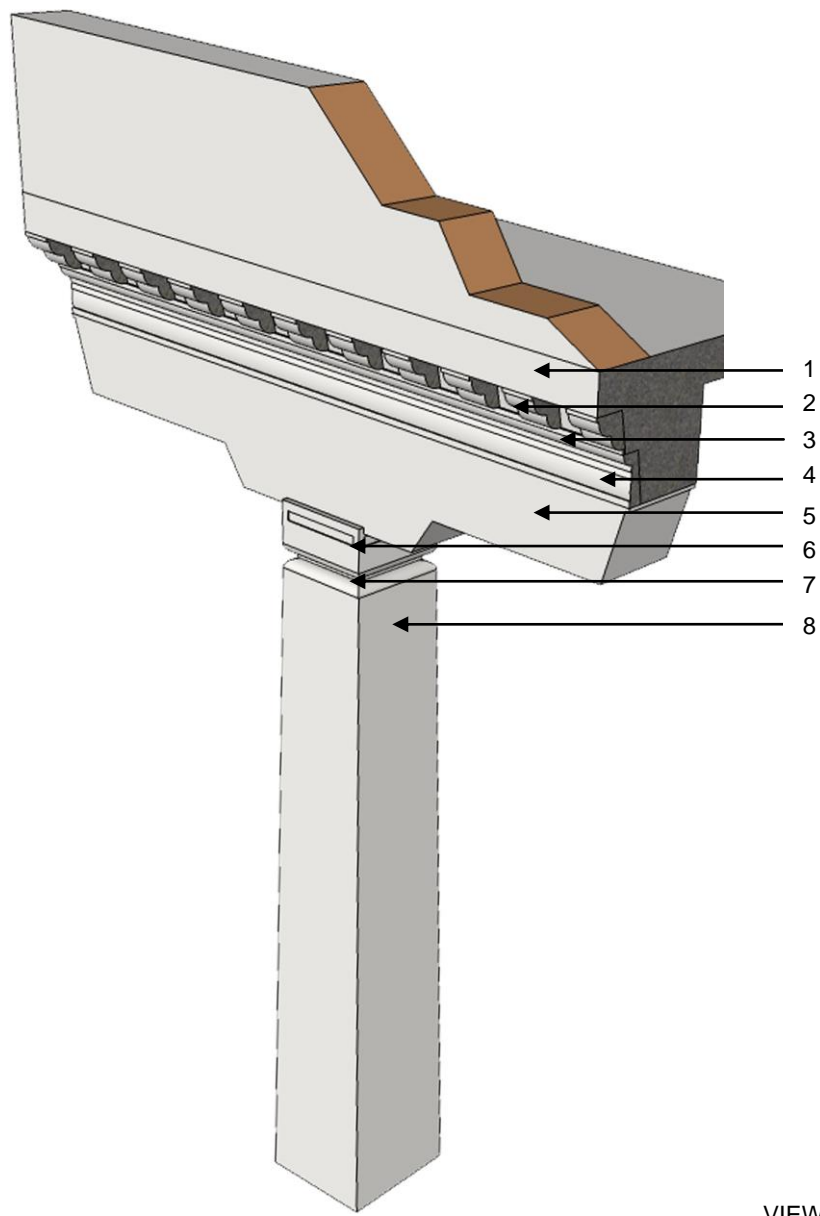

VIEWS

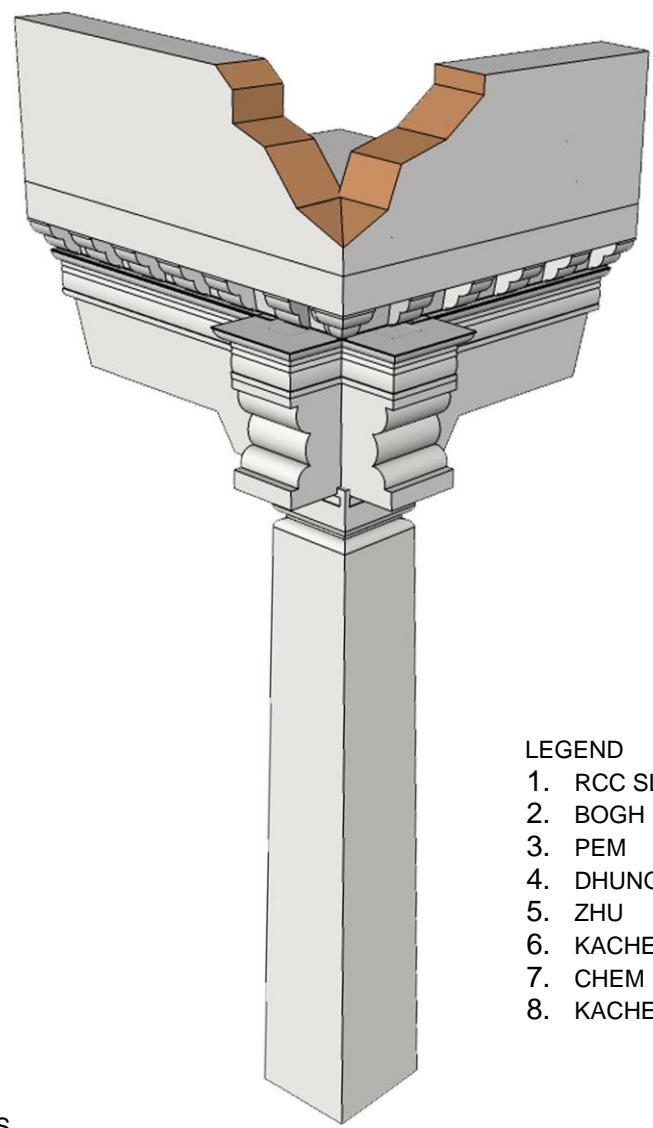

- LEGEND
- 1. RCC SLAB
 - 2. BOGH
 - 3. PEM
 - 4. DHUNG
 - 5. ZHU
 - 6. KACHEN CAPITAL
 - 7. CHEM
 - 8. KACHEN

Fig.2.1.g. KACHEN WITH SIMPLIFIED ZHU
(Drawing: Singay Daduel)

- 2.1.4. Designers/ Architect of record should provide the detail of the proportion of Zhu. (Fig. 2.1.h)
- 2.1.5. Proportion of Kachen capital, Zhu, Dhung, Pem, Choetse, Tshechu Kha-nyim and other elements to follow Thobthang and Thigtshed

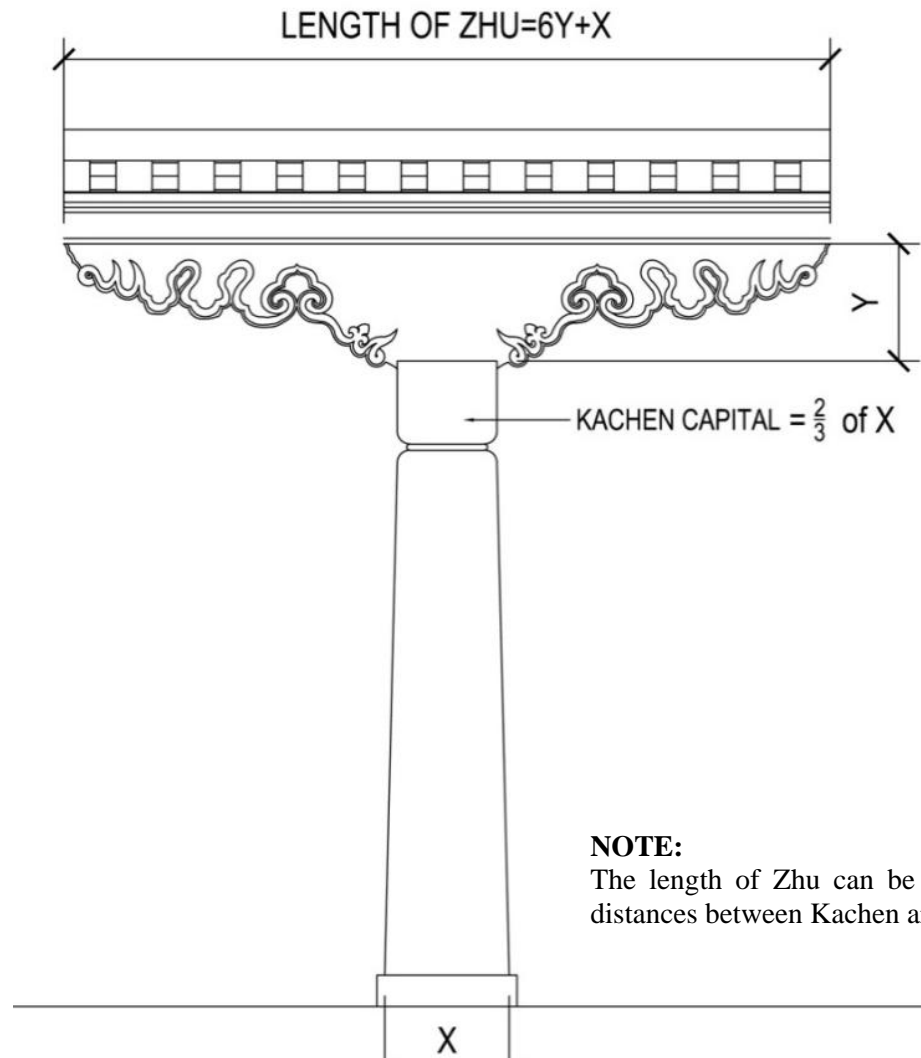

Fig.2.1.h. PROPORTION OF KACHEN AND ZHU
(Drawing: Singay Daduel)

2.2 PAYAB WINDOWS

- 2.2.1.** Minimum required elements of a Payab window are Pem, Zumchu, Bogh and Zangshing/Salen. Dhung shall be optional for commercial and residential buildings.
- 2.2.2.** If Pem-Choetse is used all around the Payab, Zumchu shall be provided instead of Dhung.
- 2.2.3.** All types of Rabsel window can be used as Payab either with or without Shamig.
- 2.2.4.** Payab windows shall never project out of the wall.
- 2.2.5.** The following recommendations are for the use of different types of Payab windows:

2.2.5.a. BYELGO PAYAB

1. **Byelgo Payab** shall not have Thrangcho.
2. It shall have cornice elements like Horzhu, Bogh, Pem-Choetse or Pem, Dhung, Kachung and Jughshing.

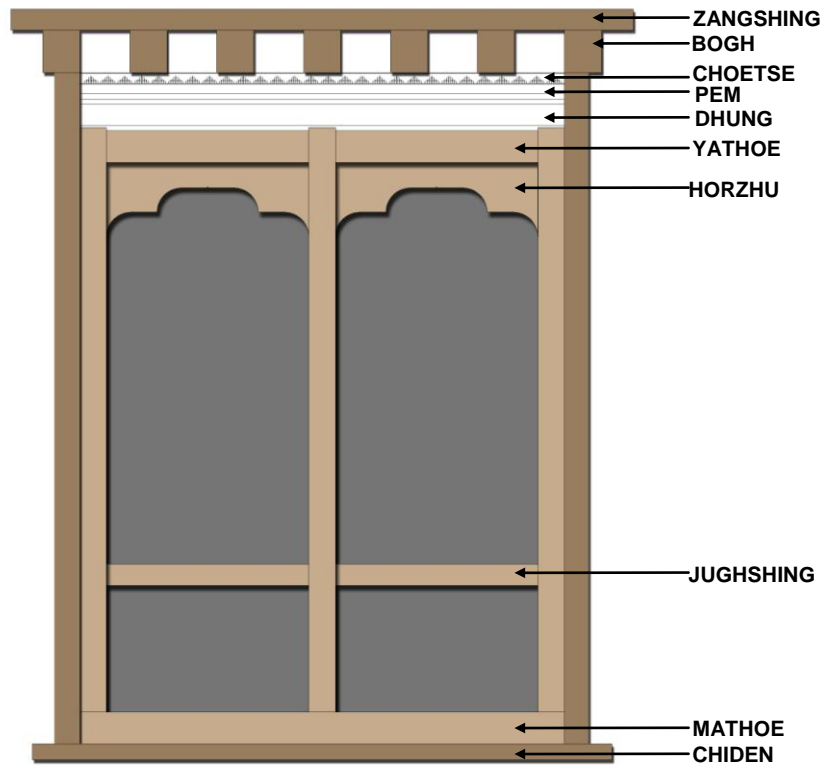

BYELGO PAYAB

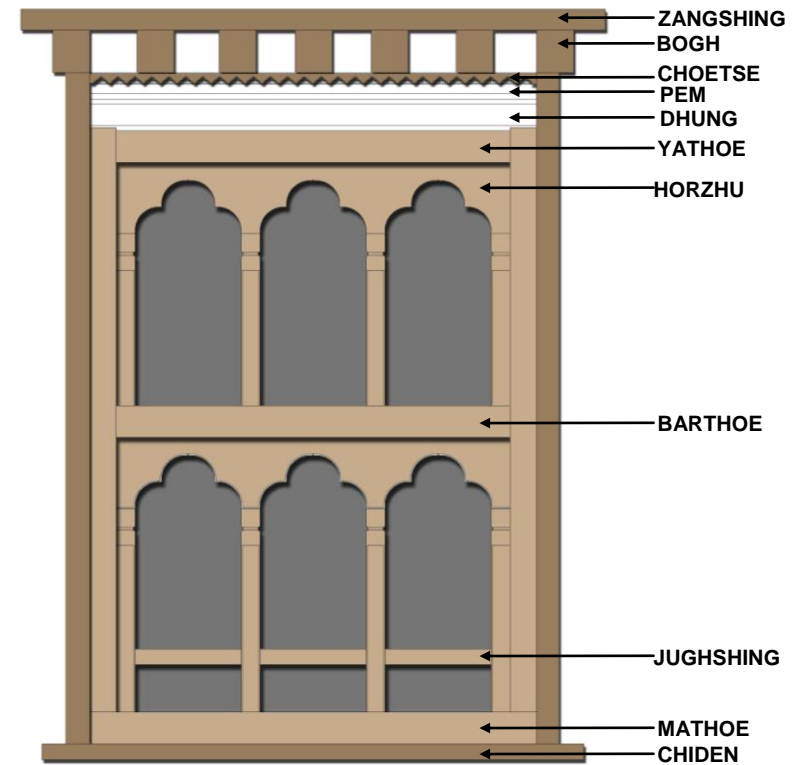

TWO TIERED BYELGO PAYAB

BYELGO PAYAB
(Drawing: Singay Dadel)

2.2.5.b. GYESARGO PAYAB

1. **Gyesargo Payab** will have low Thrangcho of maximum of 250mm high and a Jughshing at waist level.
2. It will have all the permissible cornices and Kachung and Horzhu beside Jaka but no Tshigen.

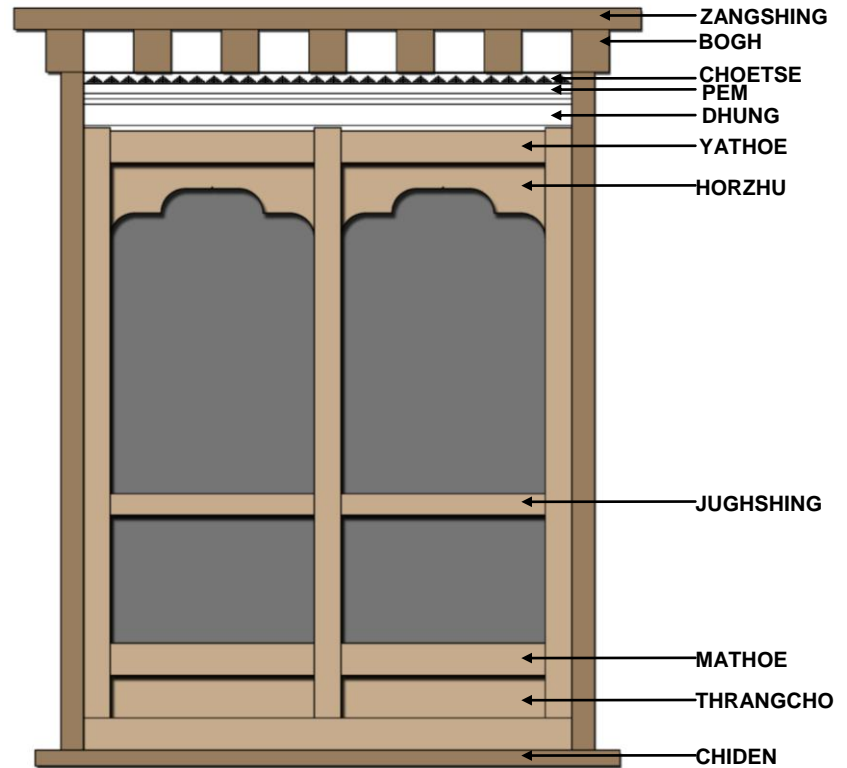

GEYSARGO PAYAB
(Drawing: Singay Daduel)

2.2.5.c. LINGO PAYAB

1. **Lingo Payab** if starting from floor level shall have Thrangcho of maximum height of 450mm and one Jughshing at appropriate height.
2. It shall not have Horzhu or Kachung or Tshigen.
3. The openings shall not be divided into many squares like in a Gedkar.
4. The Lingo Payab shall have all the permissible cornices and it shall never project out of the wall.
5. The Lingo Payab is recommended only for two storied residential buildings if constructed in only in timber.

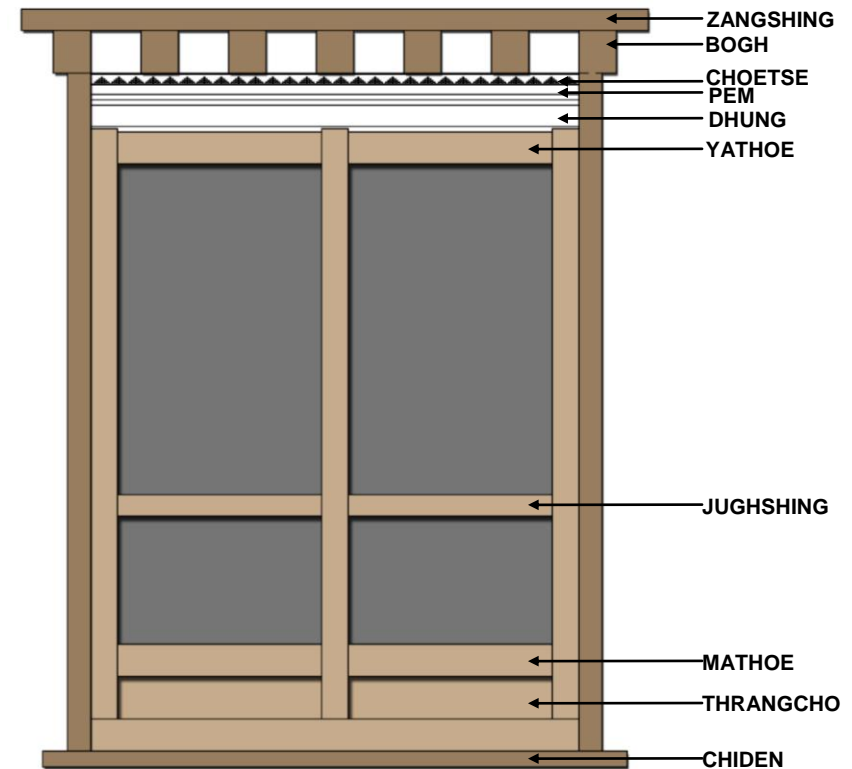

LINGO PAYAB
(Drawing: Singay Daduel)

2.2.5.d. GEDKAR PAYAB

1. **Gedkar Payab** shall not have Thrangcho and can be sub-divided into smaller openings with transoms. It can have Horzhu, Zangshing, Bogh and Zumchu but no Pem-Choetse or Dhung.
2. Gedkar shall not have Shamig, Tshigen or Kachung. The shutter frame shall be hidden behind the window frame.
3. Gedkar Payabs shall be narrow in appearance compared to other Payabs.

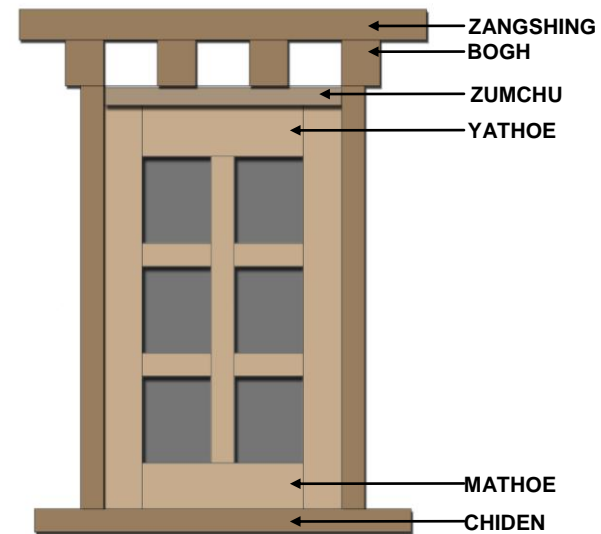

GEDKAR PAYAB
(Drawing: Singay Daduel)

2.2.6. PAYAB HIERARCHY.

The recommended Payab hierarchy in descending order of appearance in facades is as follows:

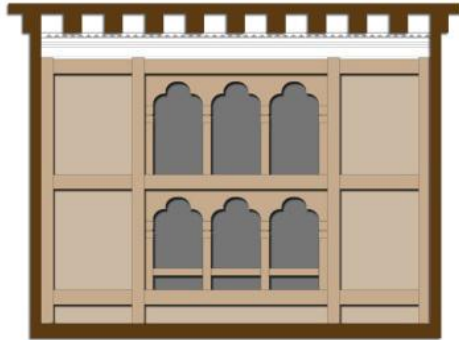

a. Payab with Shamig and Thrangcho

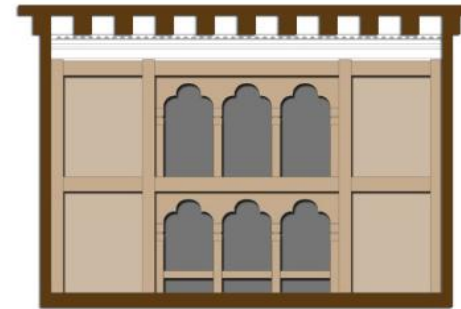

a1. Payab with Shamig without Thrangcho

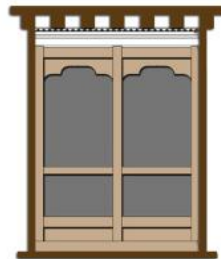

b. Payab with Thrangcho

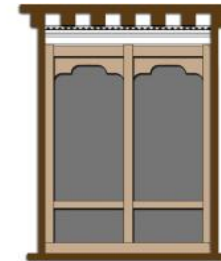

b1. Payab without Thrangcho



c. Gedkar Payab is usually the lowest in hierarchy

PAYAB HIERARCHY
(Drawing: Singay Daduel)

2.3 RABSEL WINDOWS

- 2.3.1.** Rabsel projections and Thobthang of cornices shall depend on whether it is single, double or triple tiered.
- 2.3.2.** When a Rabsel is provided either on the whole facade (Go-Cham Rabsel) or partial (Lobur Rabsel) of the building, the cornice on the top should be turned and continued till the face of the masonry wall. The top cornice of the Rabsel should not be terminated abruptly. Side elevation of Rabsel should also be treated properly.
- 2.3.3.** It is recommended to have a Rabsel with all the elements for the topmost floor of all commercial and institutional multi storey buildings.
- 2.3.4.** The Go-cham Rabsel for multi storied buildings may be single or double ONLY as shown in Fig.2.3.a and Fig.2.3.b.

Single tiered Go-cham Rabsel
with single tiered window

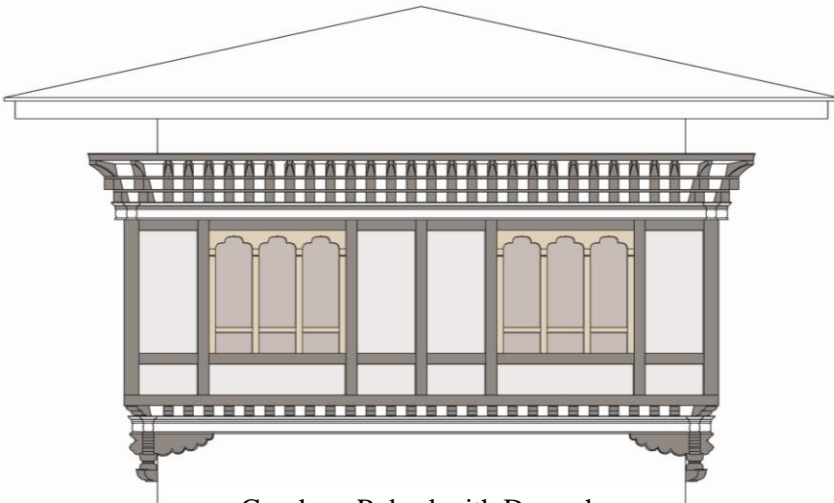

Go-cham Rabsel with Drey-zhu

Single tiered Go-cham Rabsel
with double tiered window

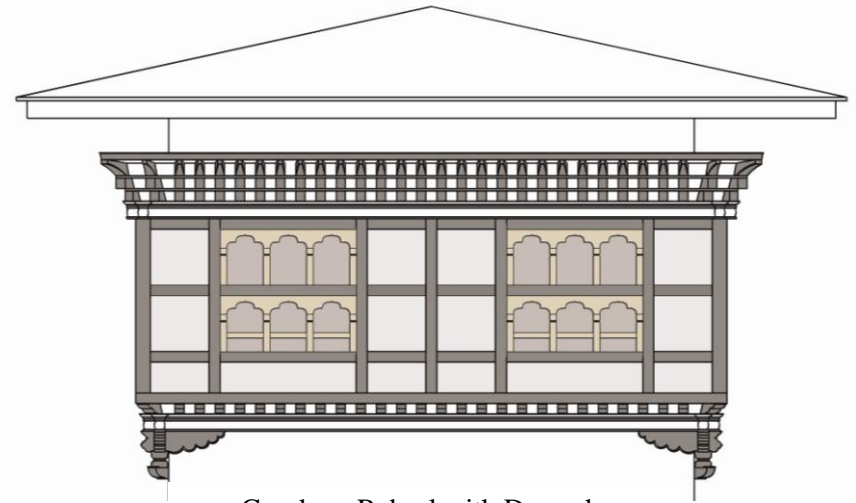

Go-cham Rabsel with Drey-zhu

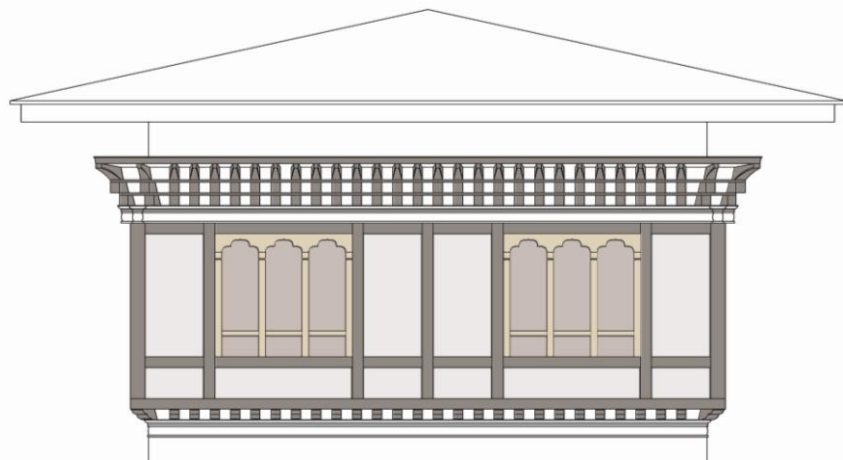

Go-cham Rabsel without Drey-zhu

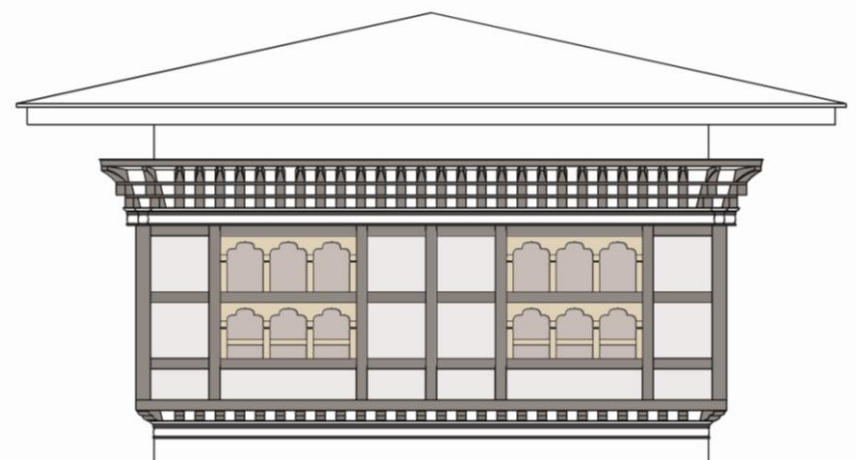

Go-cham Rabsel without Drey-zhu

Fig.2.3.a. SINGLE TIERED GO-CHAM RABSEL
(Drawing: Sonam Tobgay)

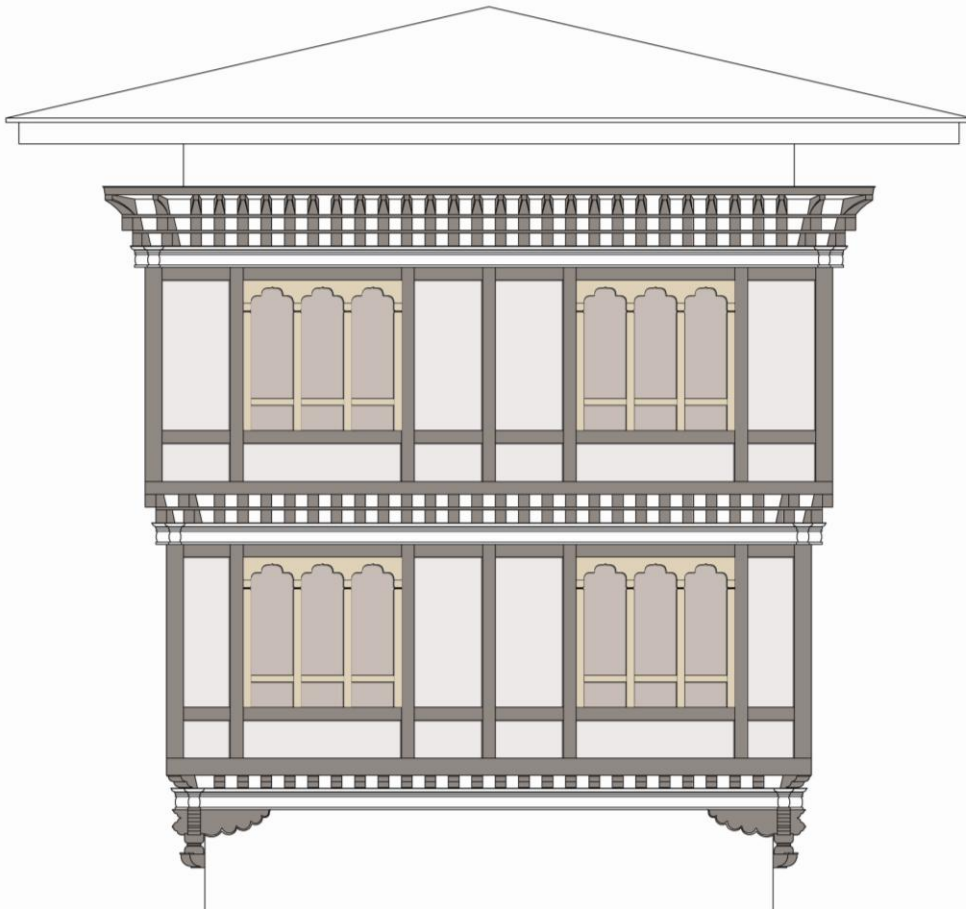

Go-cham Rabsel with Drey-zhu

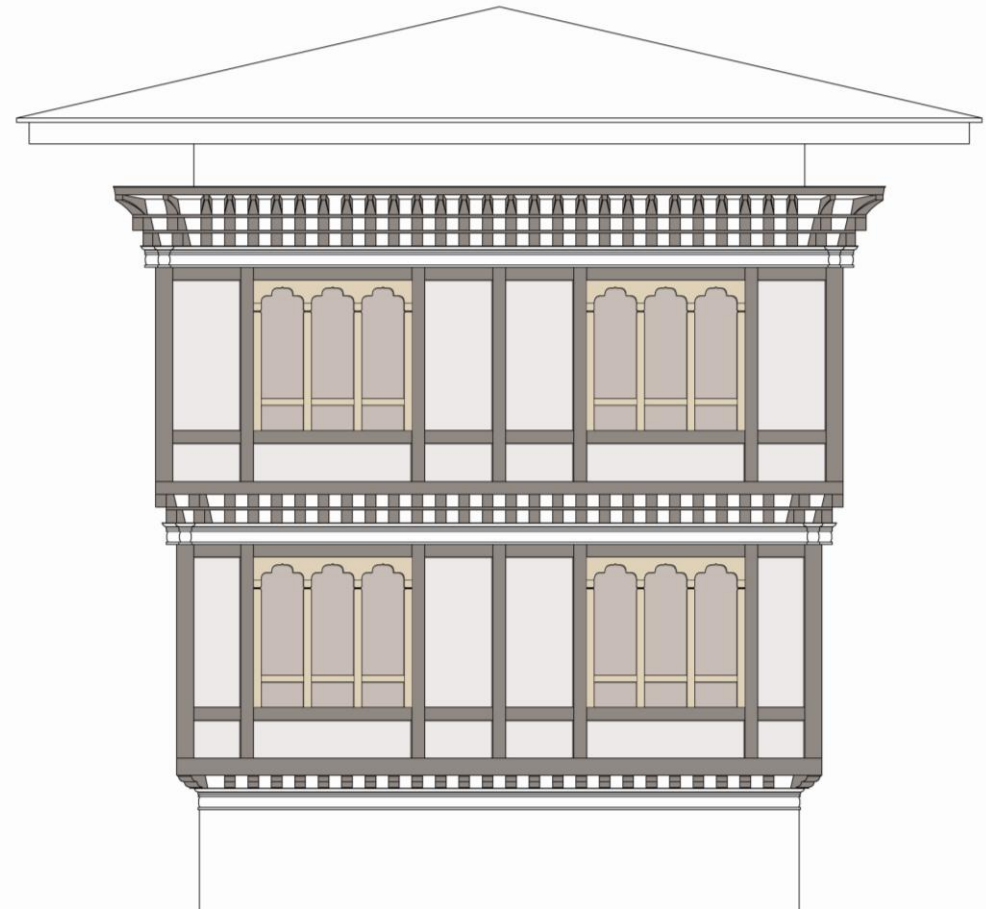

Go-cham Rabsel without Drey-zhu

Double tiered Go-cham Rabsel with single tiered window

Fig.2.3.b. DOUBLE TIERED GO-CHAM RABSEL
(Drawing: Sonam Tobgay)

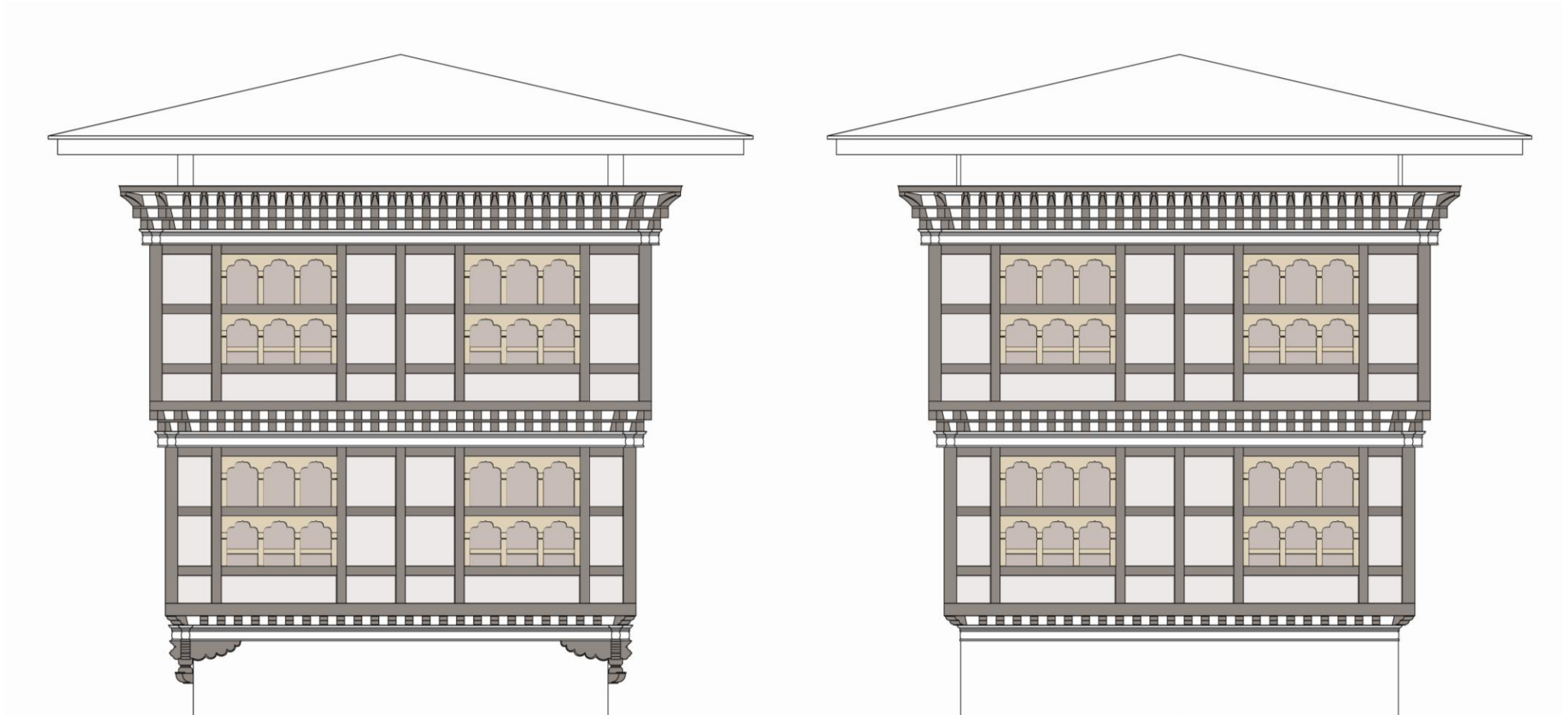

Go-cham Rabsel with Drey-zhu

Go-cham Rabsel without Drey-zhu

Double tiered Go-cham Rabsel with double tiered window

Fig.2.3.b. DOUBLE TIERED GO-CHAM RABSEL
(Drawing: Sonam Tobgay)

2.3.5. The Lobur Rabsel for multi-storeyed buildings shall not be more than 3 tiers as shown in Fig2.3.c, Fig2.3.d and Fig2.3.e.

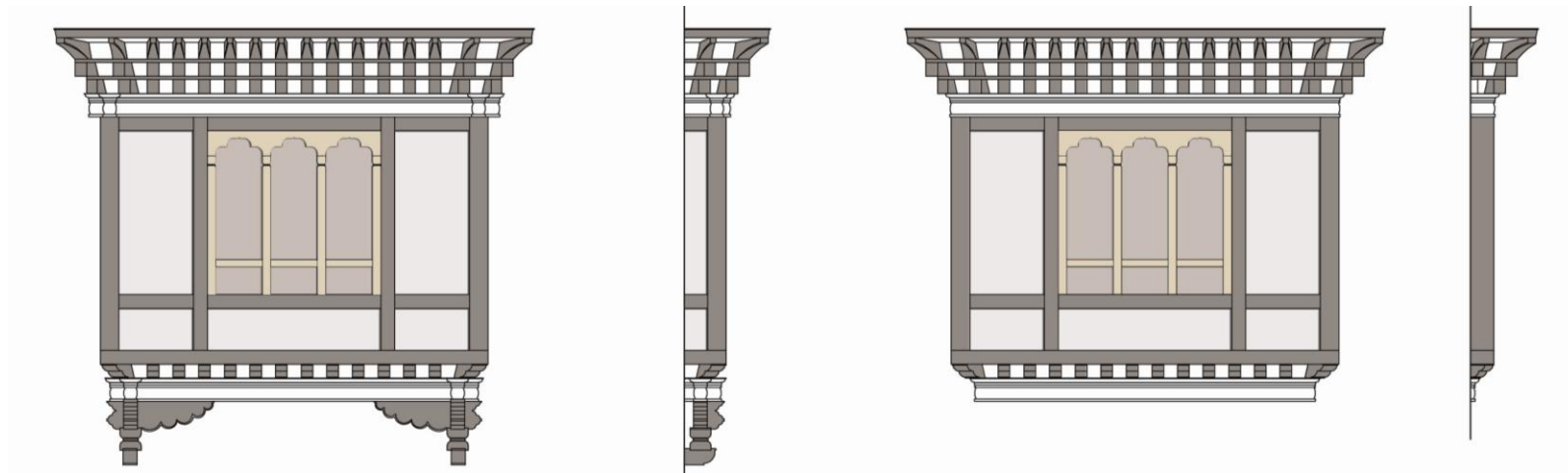

Lobur Rabsel with Drey-zhu

Lobur Rabsel without Drey-zhu

Single tiered Lobur Rabsel with single tiered window

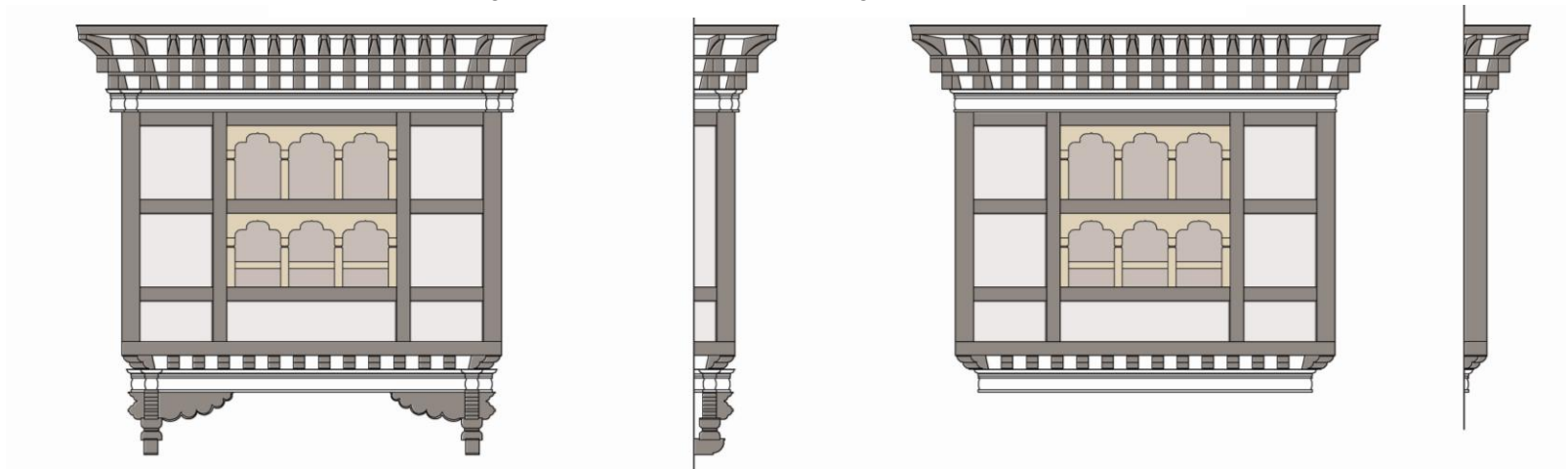

Lobur Rabsel with Drey-zhu

Lobur Rabsel without Drey-zhu

Single tiered Lobur Rabsel with double tiered window

Fig.2.3.c. SINGLE TIERED LOBUR RABSEL
(Drawing: Deki Choden)

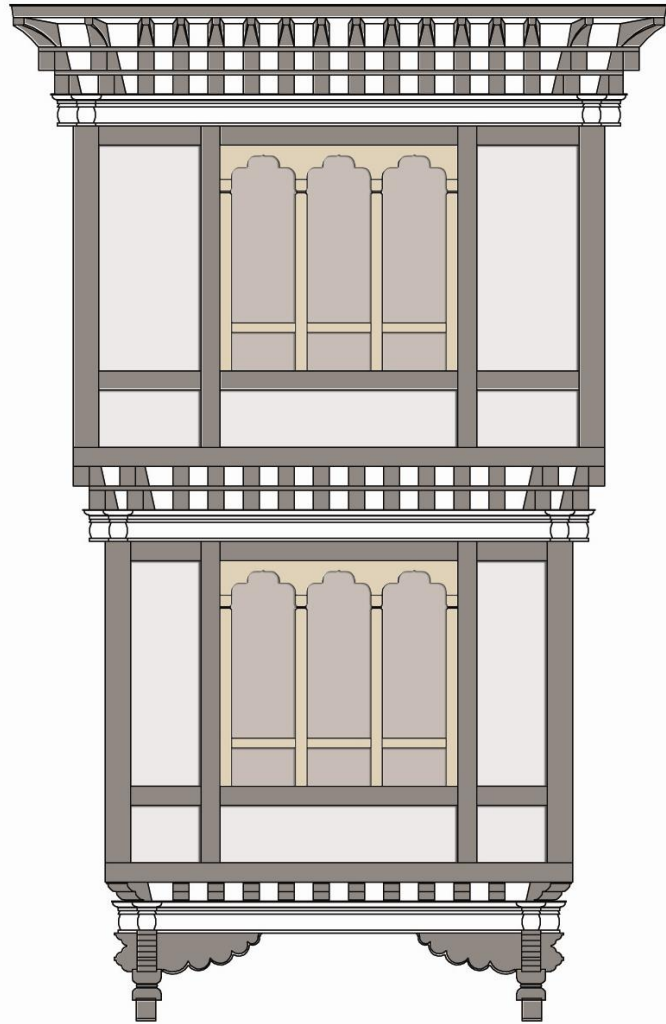

Lobur Rabsel with Drey-zhu

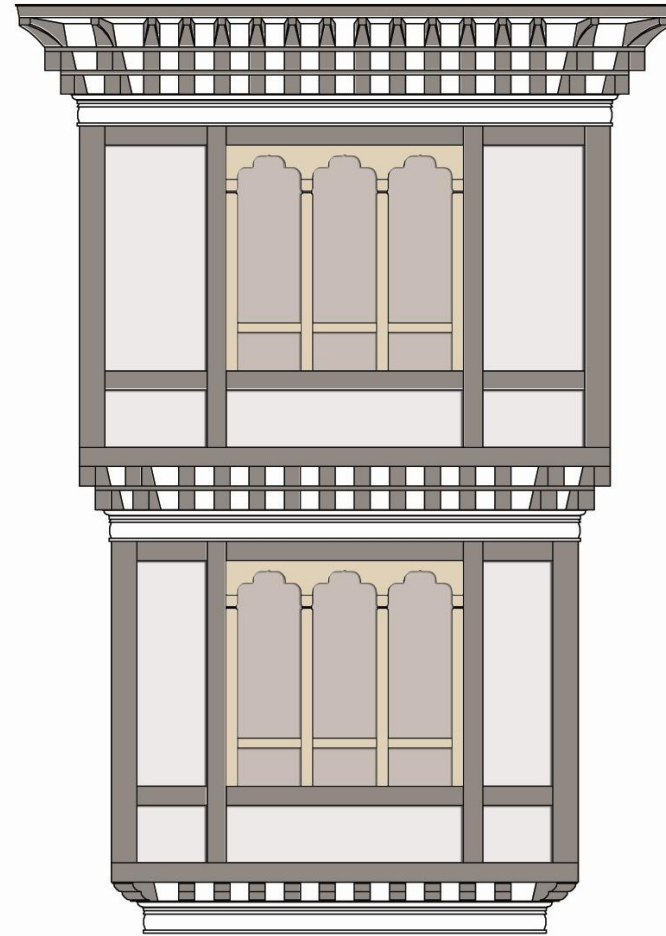
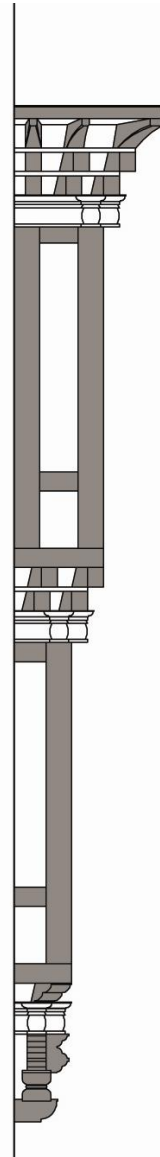

Lobur Rabsel without Drey-zhu

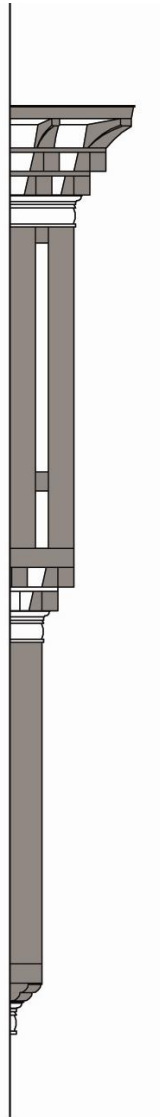

Double tiered Lobur Rabsel with single tiered window

Fig.2.3.d.DOUBLE TIERED LOBUR RABSEL
(Drawing: Deki Choden)

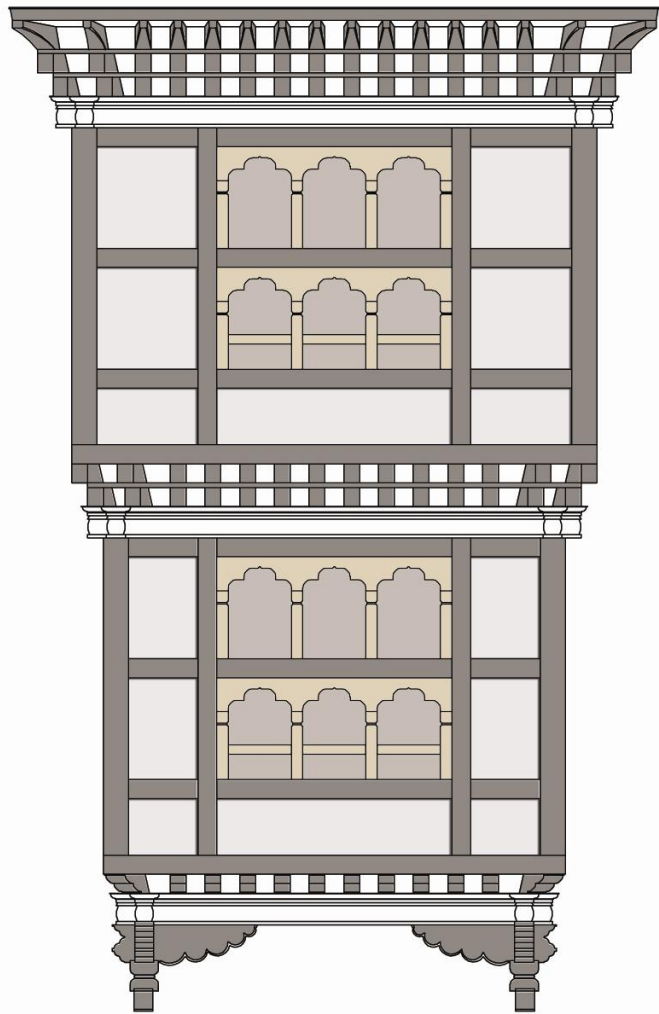

Lobur Rabsel with Dray-zhu

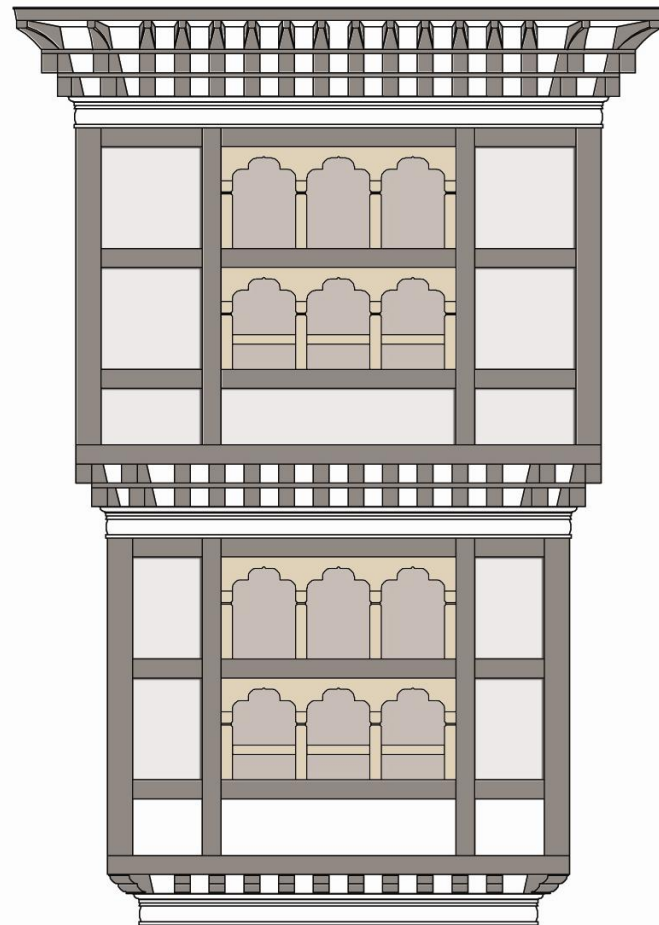
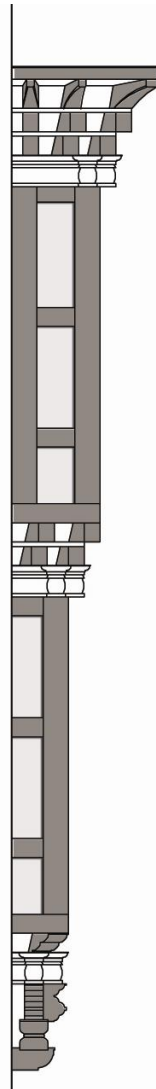

Lobur Rabsel without Dray-zhu

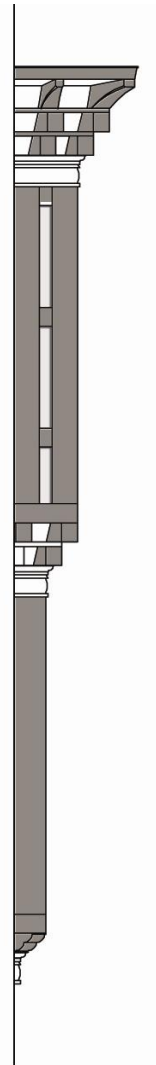

Double tiered Lobur Rabsel with double tiered window

Fig.2.3.d. DOUBLE TIERED LOBUR RABSEL
(Drawing: Deki Choden)

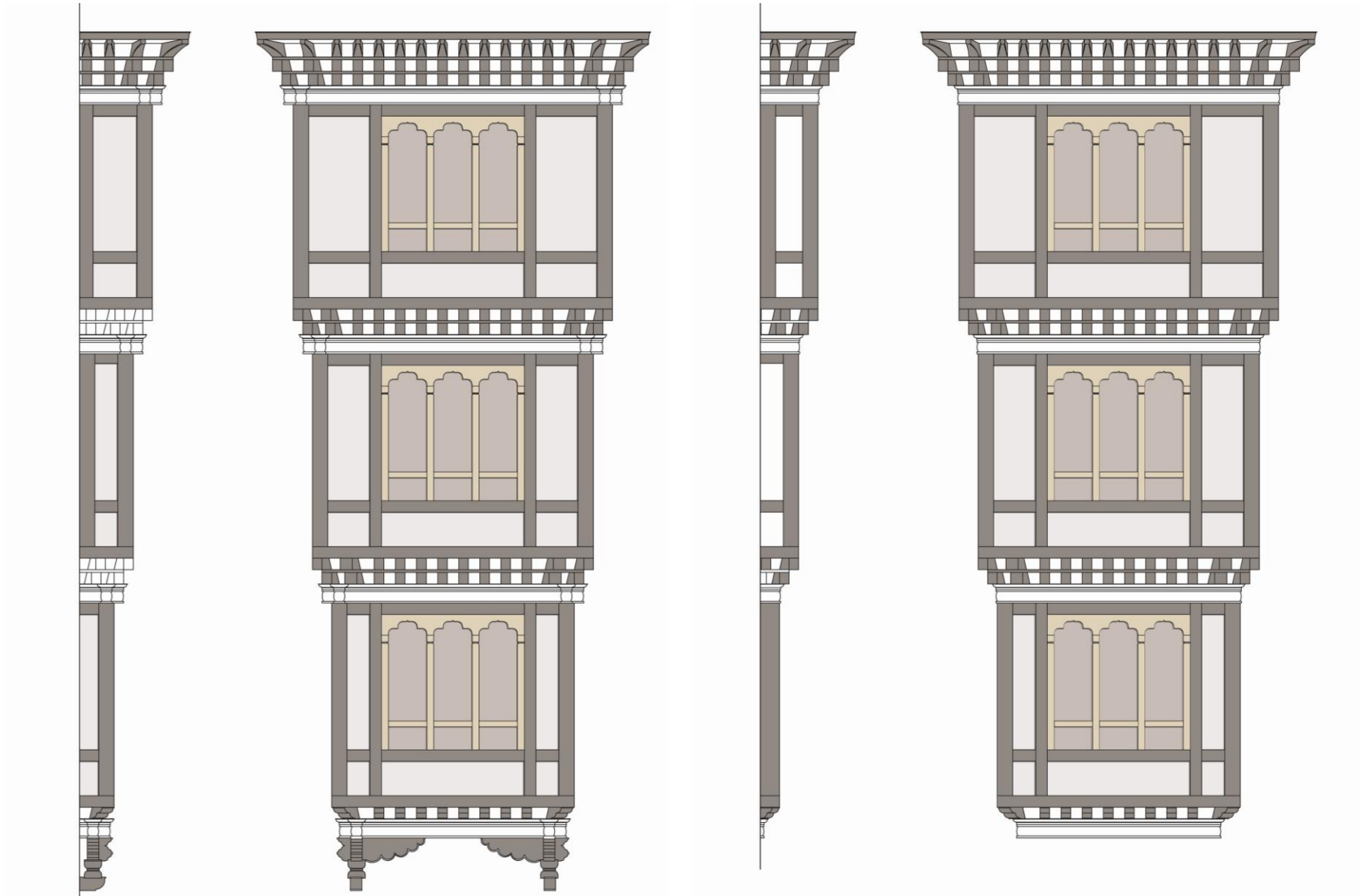

Lobur Rabsel with Drey-zhu

Lobur Rabsel without Drey-zhu

Tripled tiered Lobur Rabsel with single tiered window

Fig.2.3.e.TRIPLE TIERED LOBUR RABSEL

(Drawing: Phuntsho Tenzin)

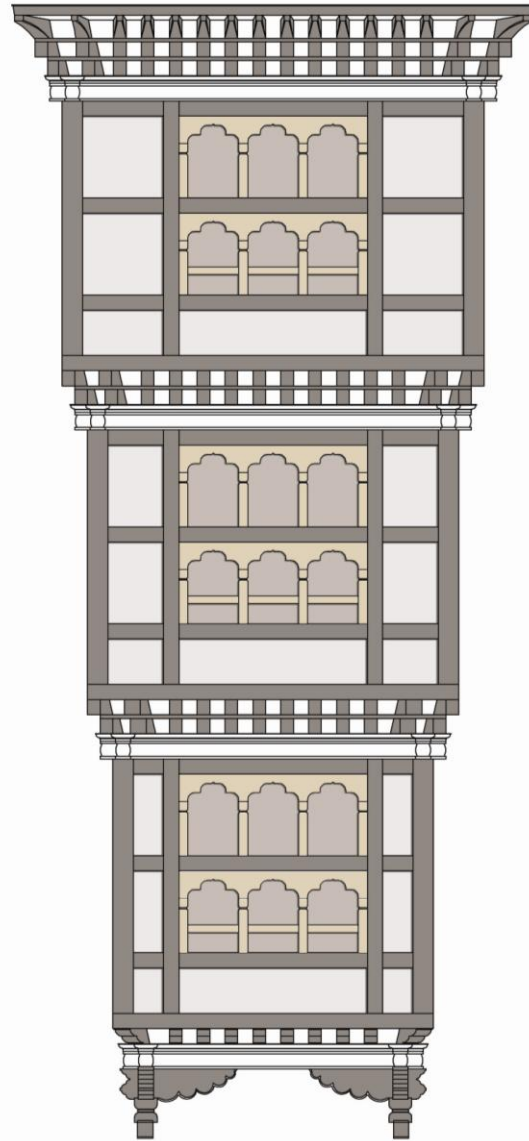
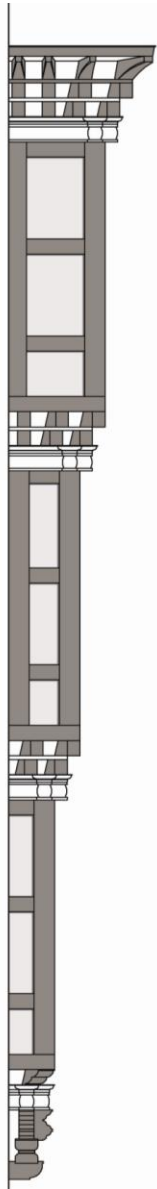

Lobur Rabsel with Drey-zhu

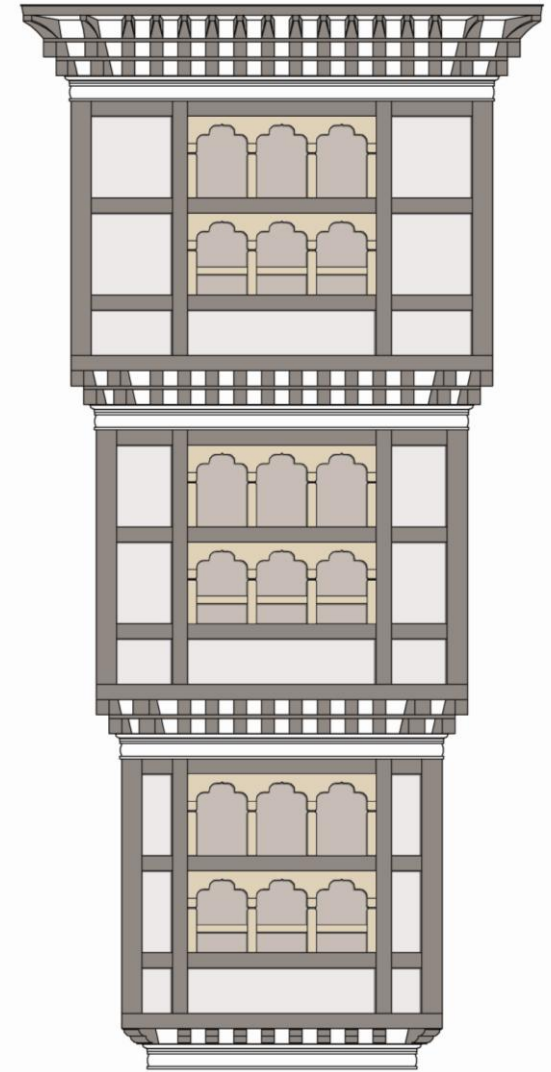
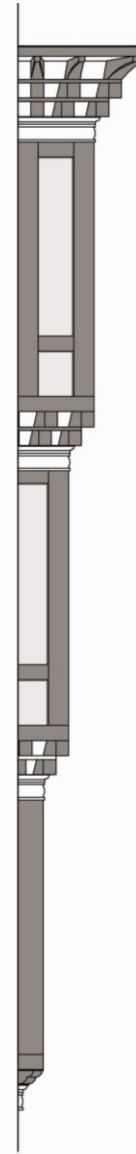

Lobur Rabsel without Drey-zhu

Tripled tiered Lobur Rabsel with double tiered window

Fig.2.3.e.TRIPLE TIERED LOBUR RABSEL

(Drawing: Phuntsho Tenzin)

2.3.6. The Byelgo Rabsel is recommended only for 2 storied buildings as shown in Fig.2.3.f. Recommended in timber only.

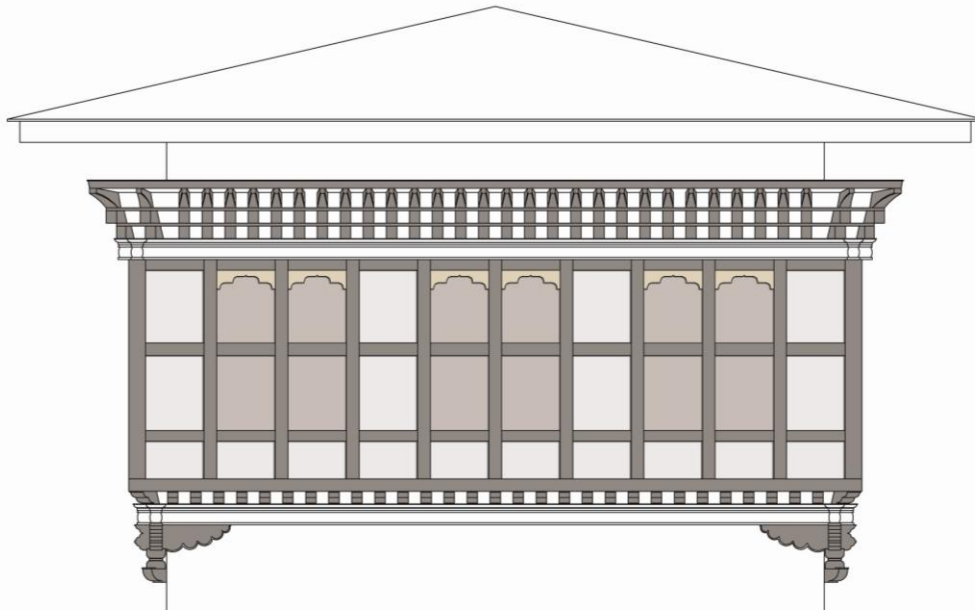

Byelgo Rabsel with Drey-zhu

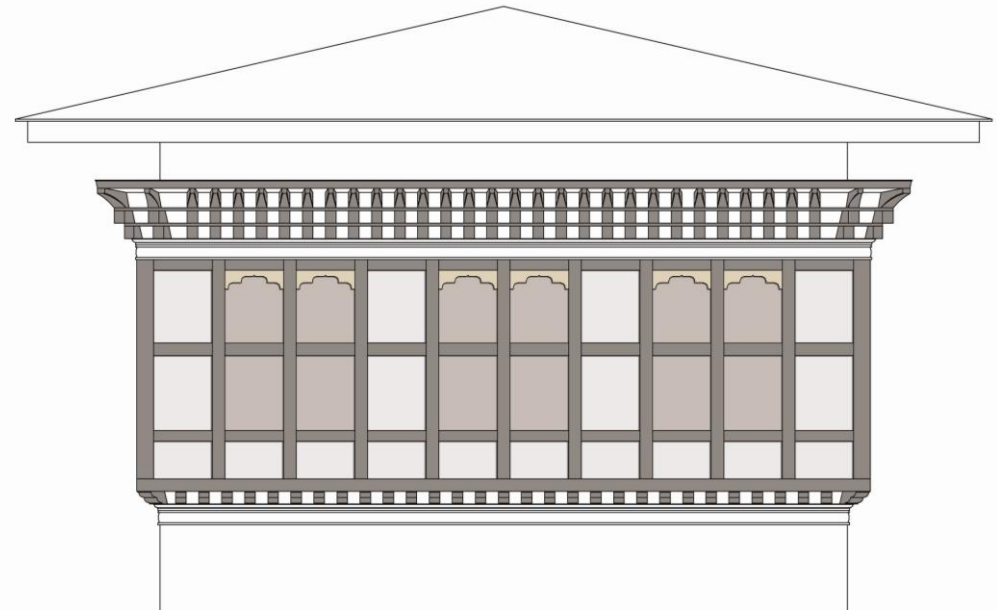

Byelgo Rabsel without Drey-zhu

Fig.2.3.f. BYELGO RABSEL
(Drawing: Tshering Denka)

2.3.7. Typical sections and details of Rabsel in modern materials are shown in Fig2.3.g, Fig2.3.h and Fig2.3.i.

2.3.8. When a Rabsel is constructed in plaster the size of Rabsel members are given in table 2.4.1.a.

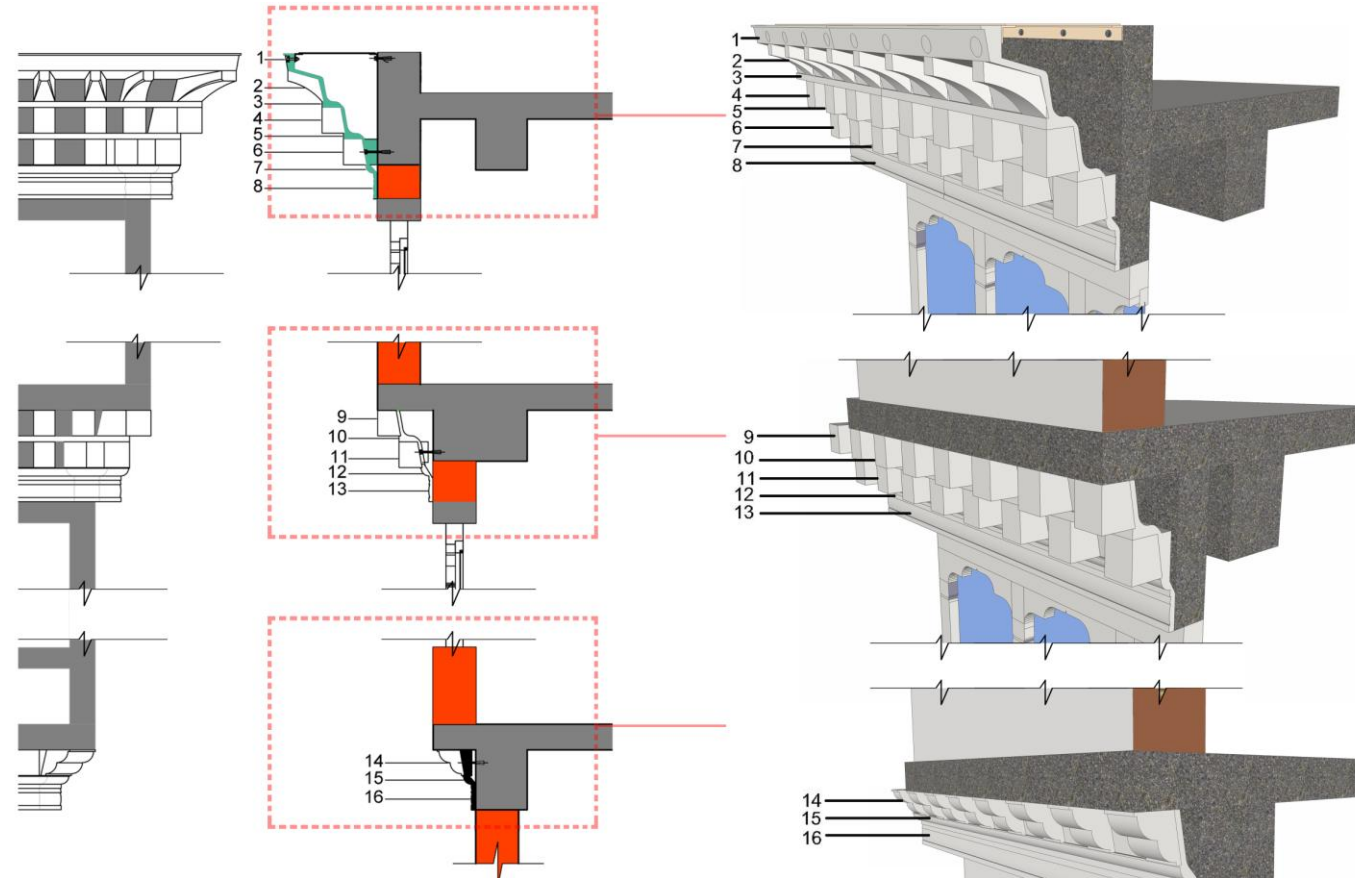

LEGEND

- | | | |
|-------------|--------------|--------------------------|
| 1. PHAKHEP | 7. PEM | 13. DHUNG |
| 2. PHANA | 8. DHUNG | 14. TSHECHU KHA-
NYIM |
| 3. CHAMKHEP | 9. BOGH | 15. PEM |
| 4. CHAM | 10. BOGHKHEP | |
| 5. BOGHKHEP | 11. BOGH | |
| 6. BOGH | 12. PEM | |

Fig.2.3.g. TYPICAL SECTION AND DETAILS OF GRC CORNICE

(Drawing: Singay Daduel)

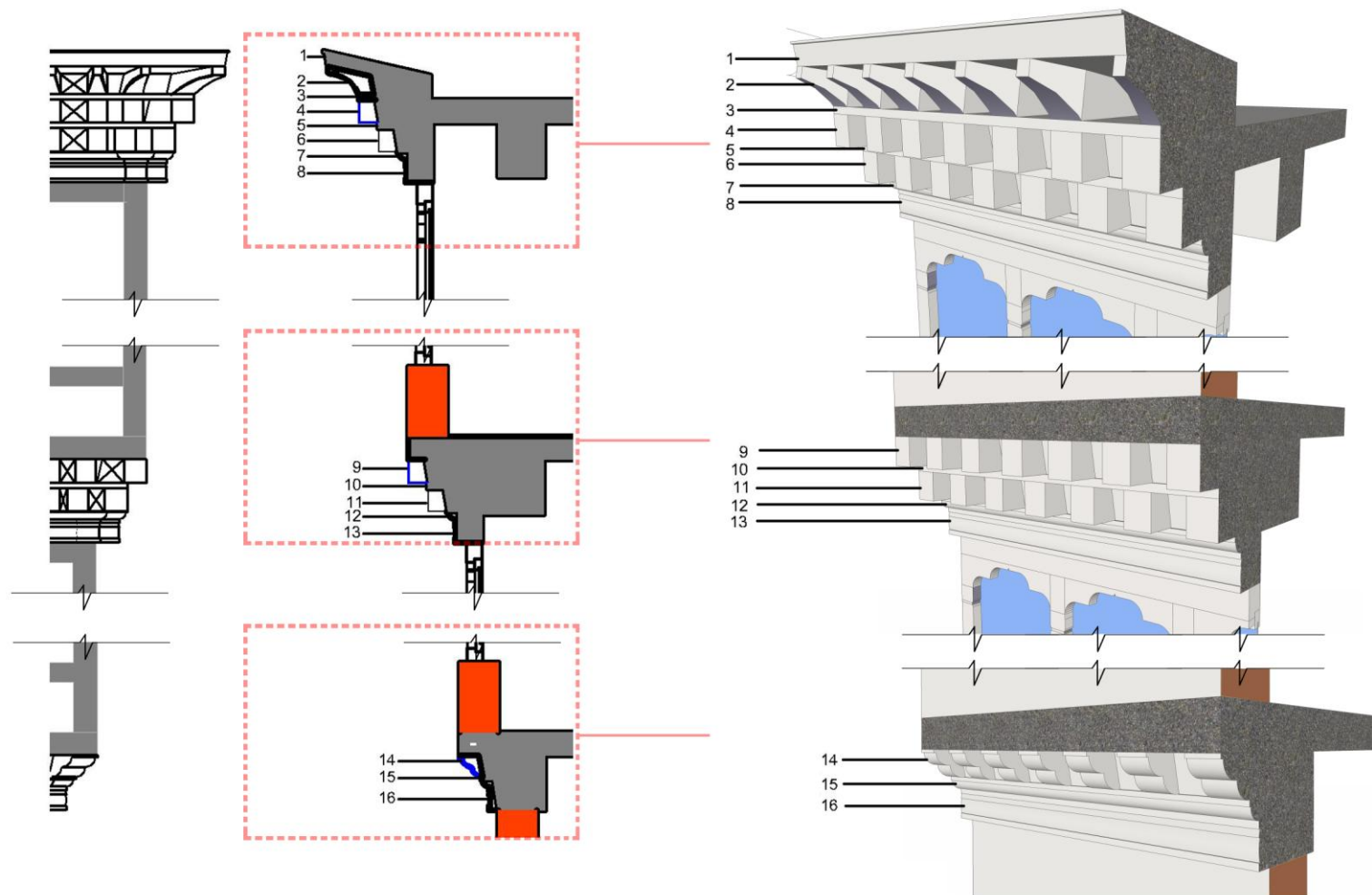

LEGEND

- | | | |
|-------------|--------------|--------------------------|
| 1. PHAKHEP | 7. PEM | 13. DHUNG |
| 2. PHANA | 8. DHUNG | 14. TSHECHU KHA-
NYIM |
| 3. CHAMKHEP | 9. BOGH | 15. PEM |
| 4. CHAM | 10. BOGHKHEP | |
| 5. BOGHKHEP | 11. BOGH | |
| 6. BOGH | 12. PEM | |

Fig.2.3.h.TYPICAL SECTION AND DETAILS OF RCC CORNICE
(Drawing: Singay Daduel)

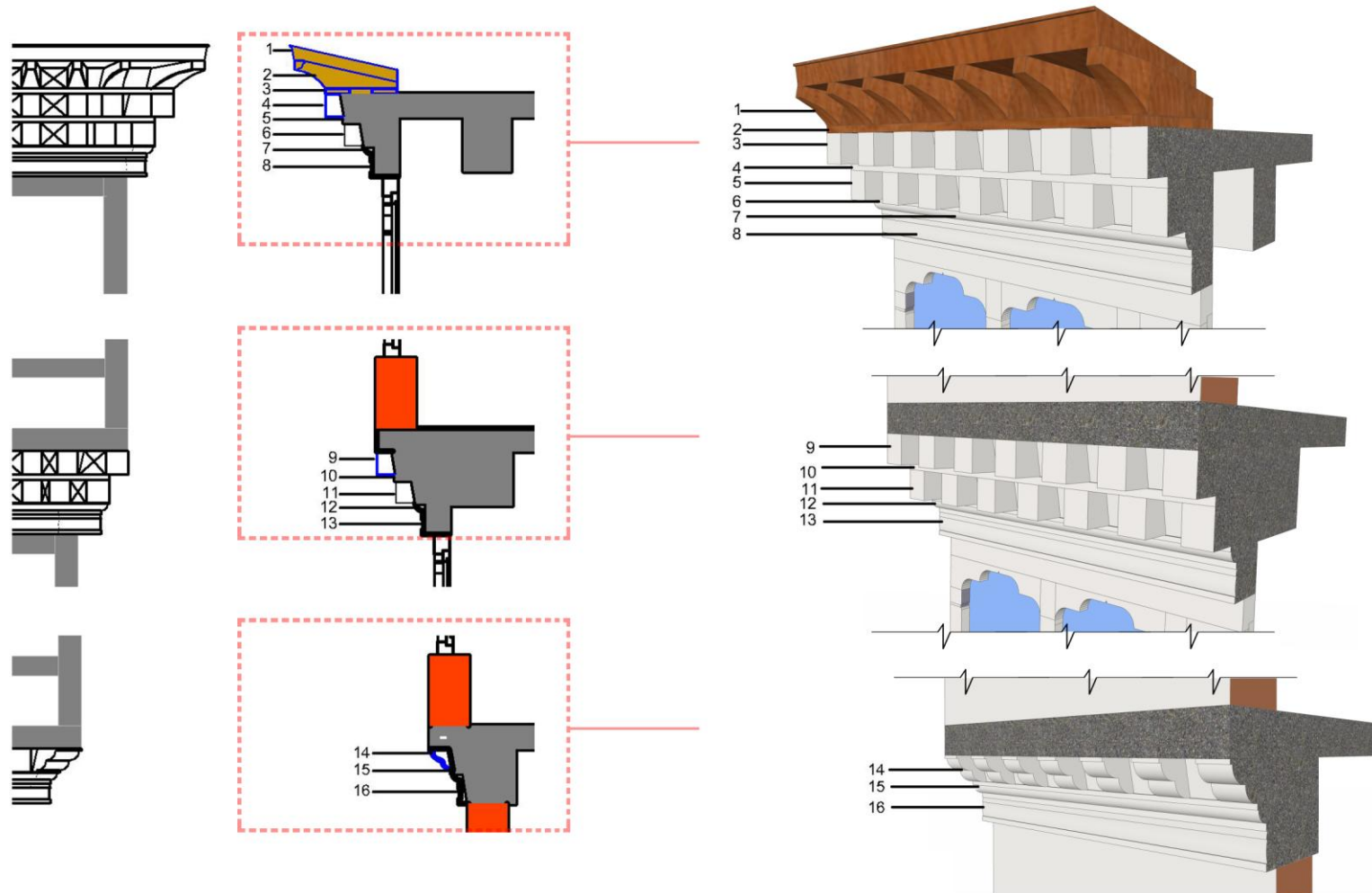

LEGEND

- | | | |
|-------------|--------------|--------------------------|
| 1. PHAKHEP | 7. PEM | 13. DHUNG |
| 2. PHANA | 8. DHUNG | 14. TSHECHU KHA-
NYIM |
| 3. CHAMKHEP | 9. BOGH | 15. PEM |
| 4. CHAM | 10. BOGHKHEP | |
| 5. BOGHKHEP | 11. BOGH | |
| 6. BOGH | 12. PEM | |

Fig.2.3.i. TYPICAL SECTION AND DETAILS OF RCC CORNICE WITH TIMBER PHANA

(Drawing: Singay Daduel)

2.4 CORNICES

The term cornice (Gucha) here shall mean the following elements like Bogh, Phana, Pem, Choetse, Dhung, Tshechu Kha-nyim, Norbu Bagum, Norbu Horzhu and their combination thereof as per Thobthang.

Recommendations for Cornices:

- 2.4.1.** Two layers of Bogh with one layer of Phana on any Rabsel. Rabsel can be supplemented by Tshechu Kha-nyim or by double layer Bogh. (See fig.2.4.a)

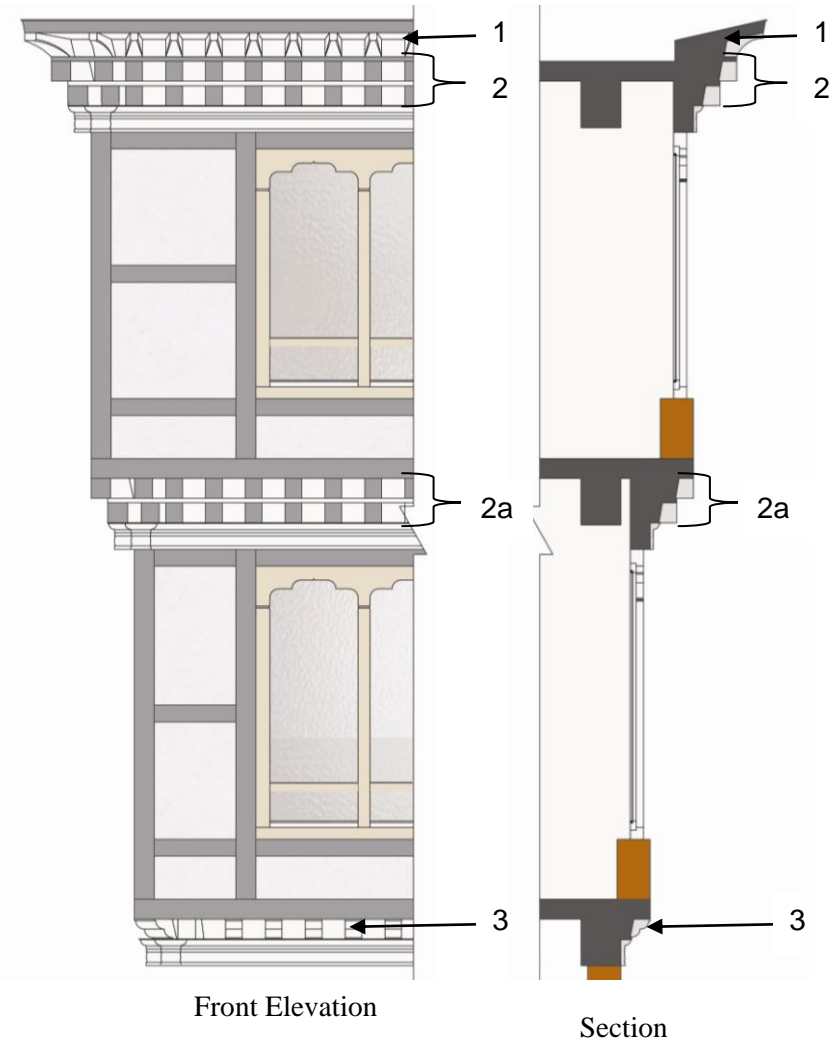
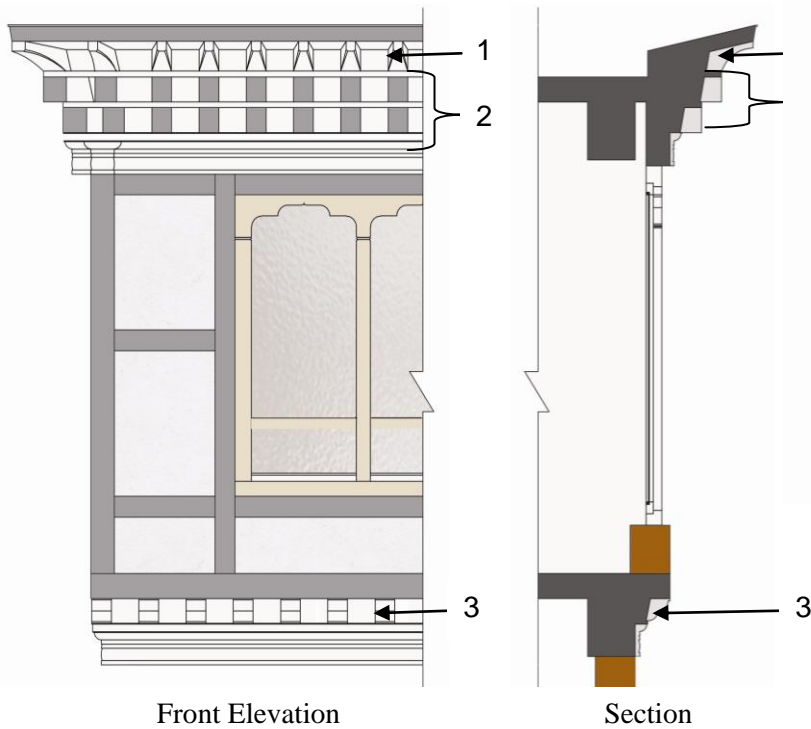

- LEGEND
1. PHANA
 2. TWO LAYERS OF BOGH
 - 2a. DOUBLE BOGH
 3. TSHECHU KHA-NYIM

Fig.2.4.a. SECTION AND ELEVATION RABSEL
(Drawing: Sunny Drukla)

2.4.2. Bogh and Phana are not mandatory on a single storey building that has only Payab windows. (See fig2.4.b.)

2.4.3. On a single storey Shamig (Ekra) building either two layers of Bogh with thicker Boghkhep may be laid or one layer of Bogh and Phana.(See fig2.4.c and fig2.4.d)



Fig.2.4.b.SINGLE STOREY WITH PAYAB WINDOW



Fig.2.4.c.SINGLE STOREY SHAMIG WITH TWO LAYERS OF BOGH



Fig.2.4.d.SINGLE STOREY SHAMIG WITH ONE LAYER OF BOGH AND PHANA

2.4.4. In double tier Rabsel, the lowest Rabsel will rest on Tshechu Kha-nyim and in between the two Rabsels double layer Bogh shall be provided. In the case where Drey Zhu is provided it shall be provided on the lowest Rabsel. (See fig2.4.e and Fig2.4.f)

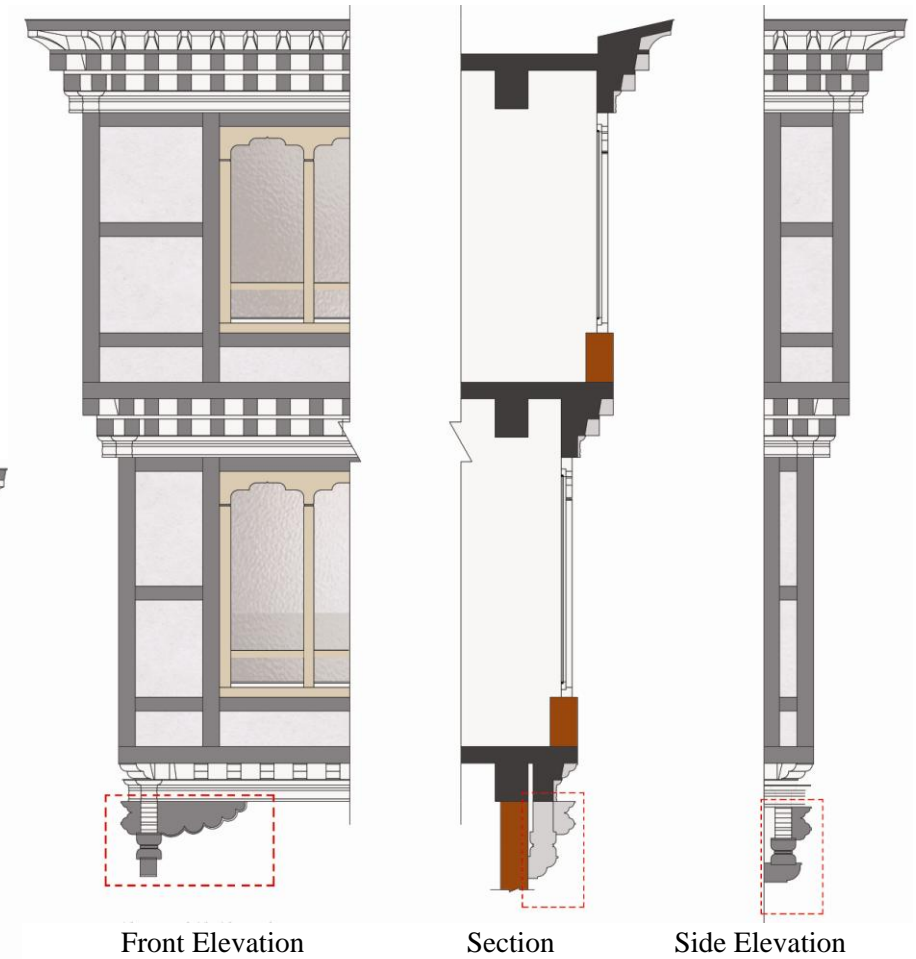
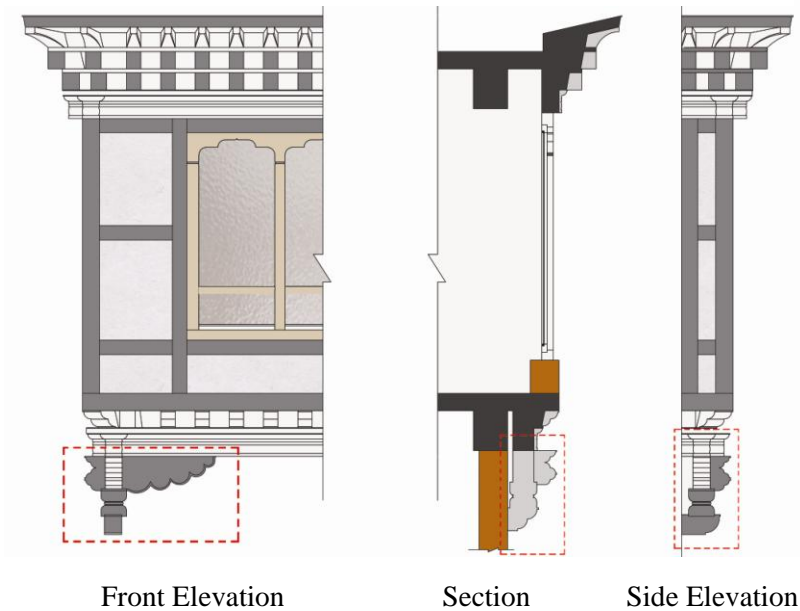
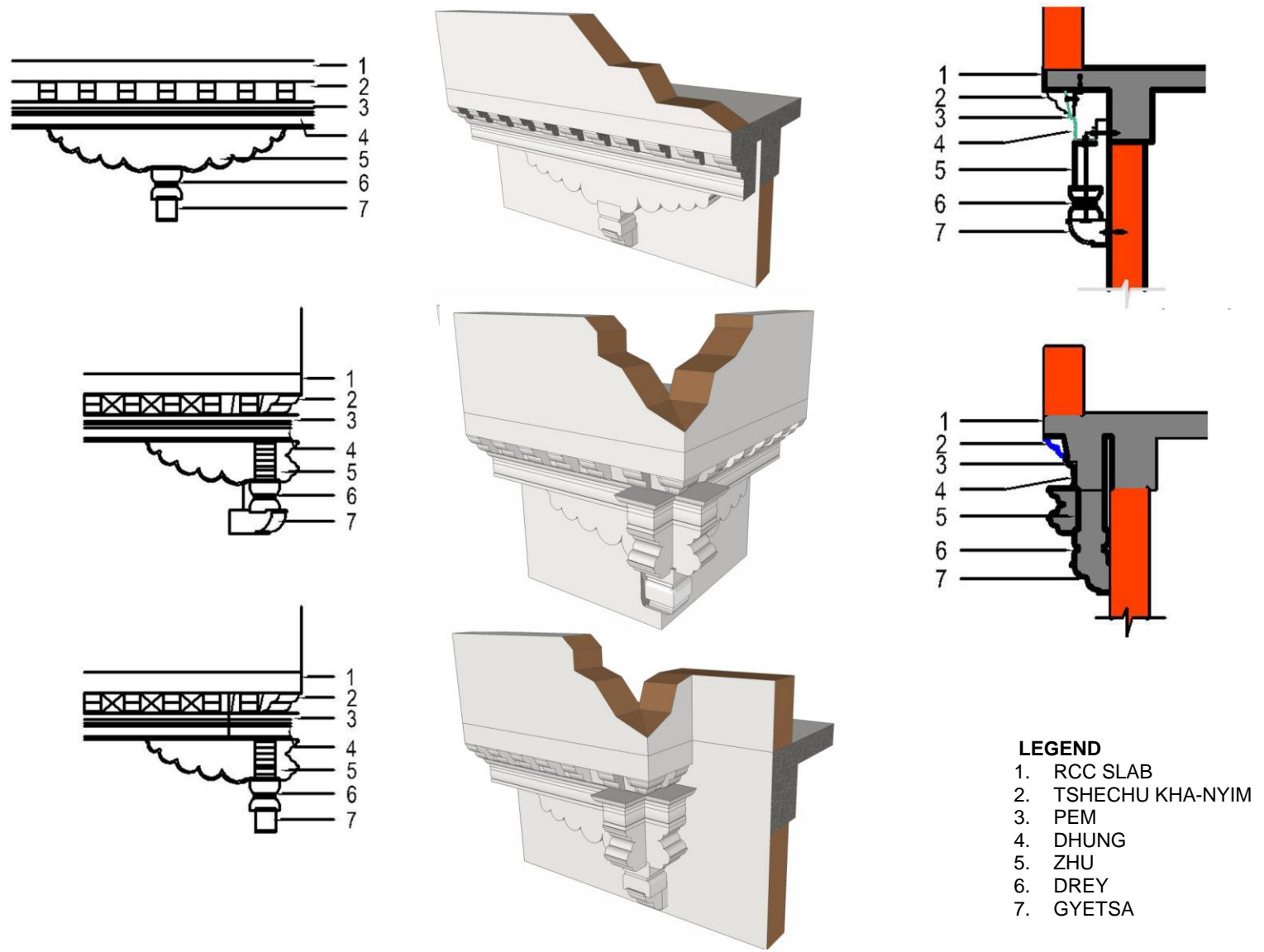

Fig.2.4.e.ELEVATION AND SECTION OF RABSEL WITH DREY-ZHU
(Drawing: Sunny Drukla)



- LEGEND**
- 1. RCC SLAB
 - 2. TSHECHU KHA-NYIM
 - 3. PEM
 - 4. DHUNG
 - 5. ZHU
 - 6. DREY
 - 7. GYETSA

Fig.2.4.e. DREY-ZHU DETAIL
(Drawing: Singay Daduel)

2.4.5. When Kachen and Zhu are used, it shall be mandatory to provide minimum cornices of Dhung, Pem and Tshechu Kha-nyim or a Bogh.(See fig2.4.g and fig2.4.h)

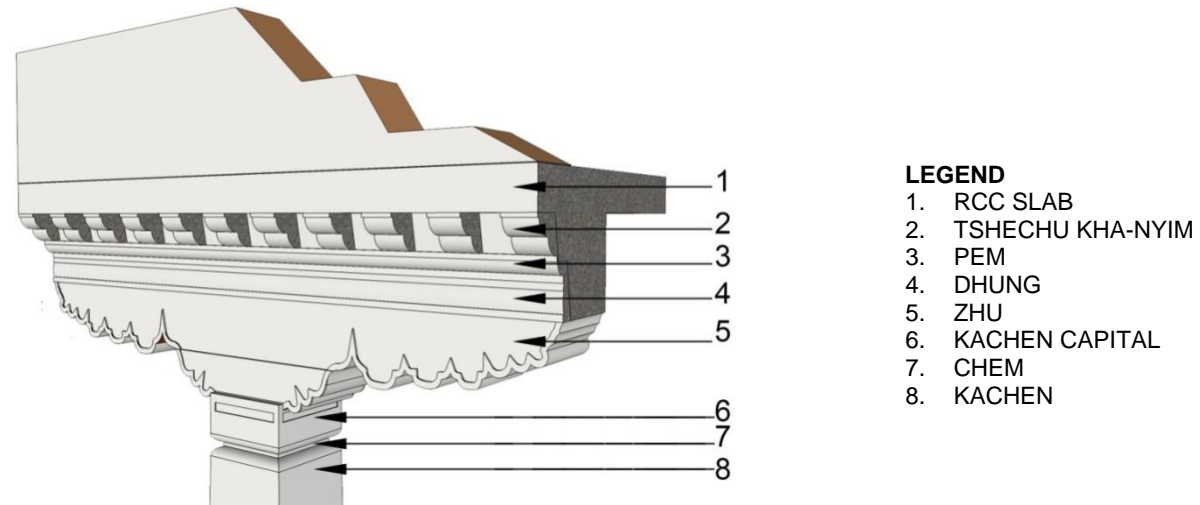

Fig.2.4.g.KACHEN AND ZHU WITH TSHECHU KHA-NYIM

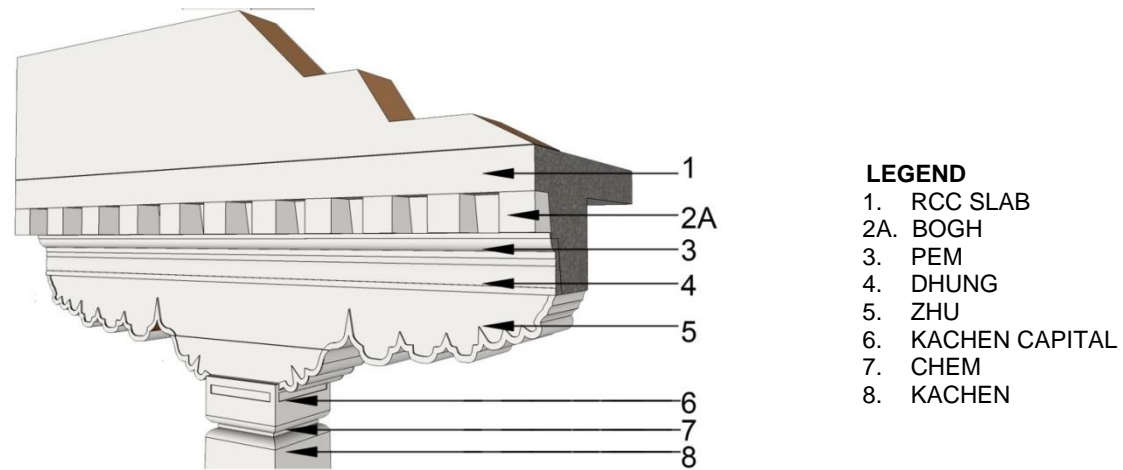

Fig.2.4.h.KACHEN AND ZHU WITH BOGH
(Drawing: Singay Daduel)

2.4.6. Recommended sizes of elements for cornice in Rabsel are shown in following Table2.4.1.a

Table 2.4.1.a. Recommended sizes for the Rabsel and Cornice members

SL.NO	MEMBERS	MINIMUM(mm)		MAXIMUM(mm)	
		B	T	B	T
1	BUDHEN	150	125	200	175
2	YATHOE	125	150	175	200
3	BARTHOE	125	150	175	200
4	MATHOE	125	150	175	200
5	THRANGCHO	200	50	300	50
6	ZUMBHU	150	150	200	200
7	LENBHU	125	150	175	200
8	JAKA	125	150	175	200
9	KACHEN	90	50	125	75
10	HORIZING/HORZHU	a	50	a	75
11	DHUNG	125	150	150	175
12	BOGH/CHAM	125	150	150	175
13	PHANA	125	150	150	175
14	BOGH/PHAKHEP	b	35	b	35-50
15	PEM CHOETSE	b	50	b	75-100
16	NORBU BAGUM	b	75	b	75-100
17	NORBU HORZHU	b	50	b	75-100
18	TSHECHU KHA-NYIM	125	150	175	200
19	JANG DHUNG	125	150		175
20	ZHU	300	175	450	200
21	DREY	200	200	300	300
22	GYETSA	150	175	175	

LEGEND:

B- Breadth or width of members seen in elevation

T- Thickness or depth of members

NOTE:

The sizes given are for the Traditional timber construction.

When different materials are used for construction the thickness of the member may not be applicable.

The size of the Kachung has to be made proportionate to the Rabsel.

Sizes 'a' and 'b' have to be derived from Rabsel proportion.

2.5 ROOFS

The roof is one the most predominant structures of any building in Bhutan. The profile, slope, overhang and height are important aspects of roof design.

The most common types of roofs used for institutional, commercial and residential buildings only, are shown in Fig.2.5.a. and Fig 2.5.b.

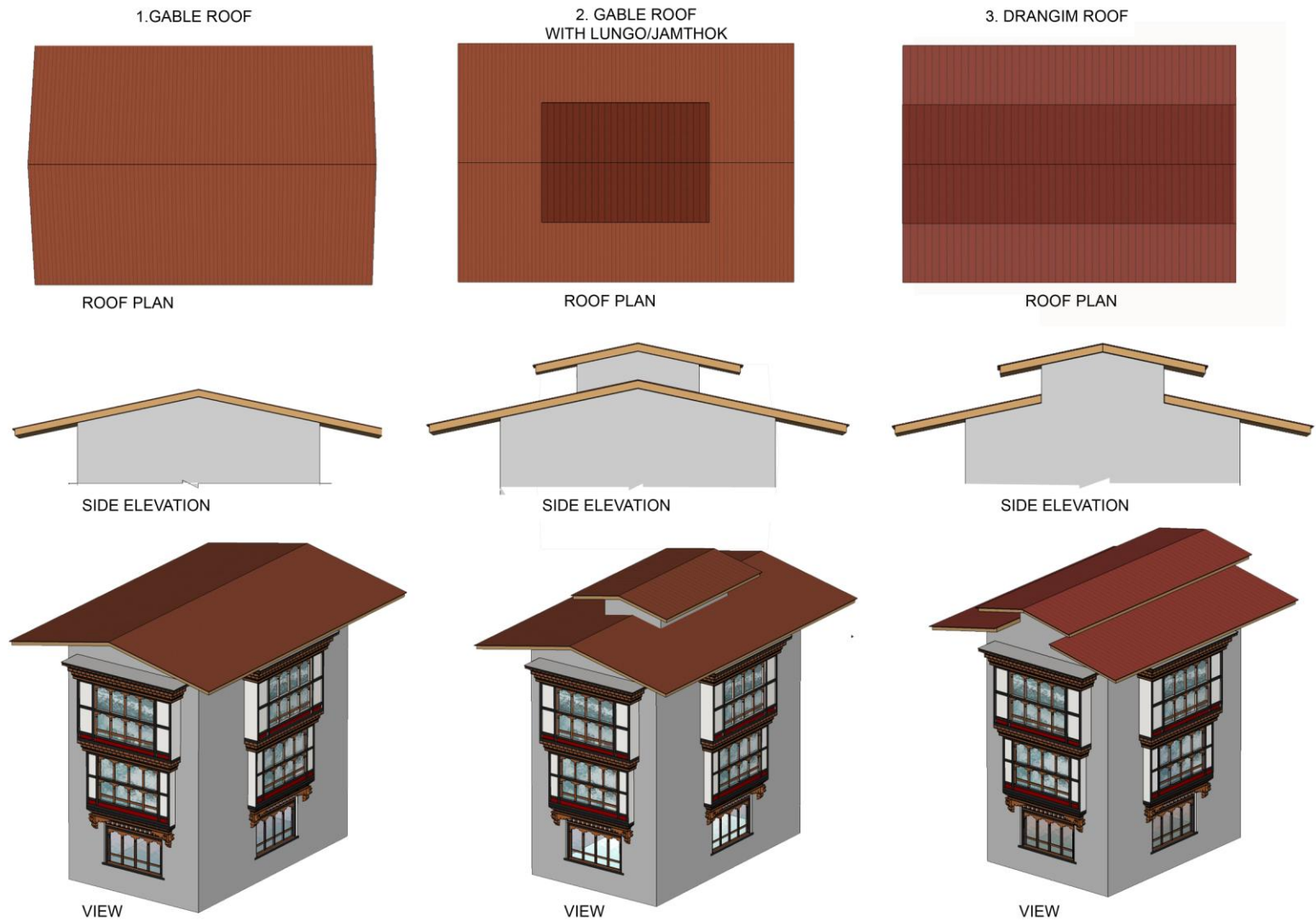
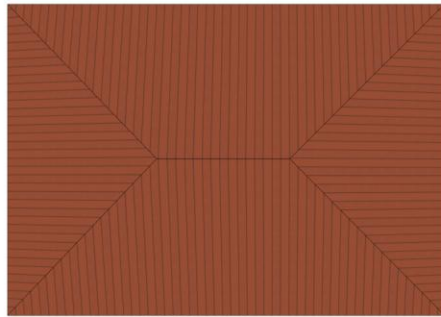
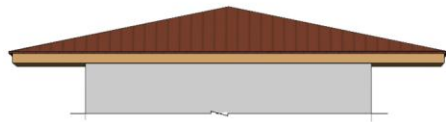

Fig.2.5.a. TYPES OF ROOF
(Drawing: Sunny Drukla)

4. HIPPED ROOF



ROOF PLAN



SIDE ELEVATION



VIEW

5. JABZHI ROOF WITH JAMTHOK

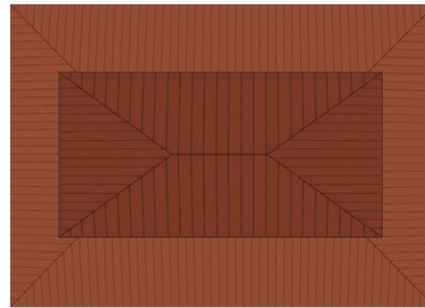

ROOF PLAN

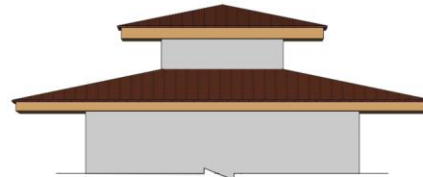

SIDE ELEVATION

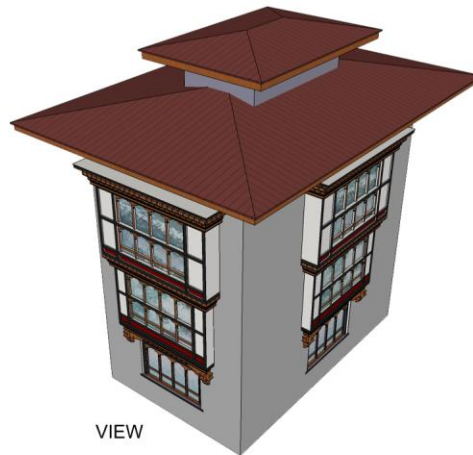

VIEW

6. JABZHI SQUARE WITH JAMTHOK AND ZHURYAB

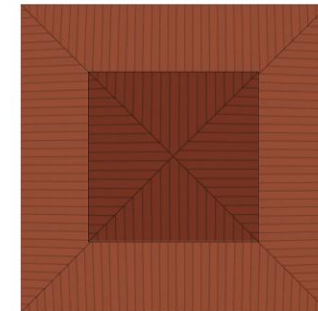

ROOF PLAN

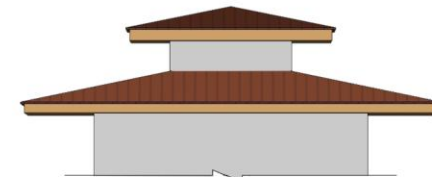

SIDE ELEVATION

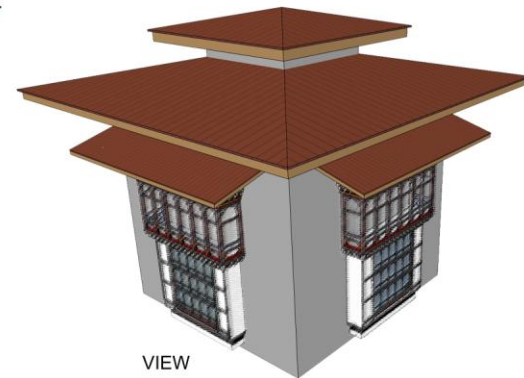

VIEW

Fig.2.5.b. TYPES OF ROOF
(Drawing: Sunny Drukla)

RECOMMENDATIONS FOR ROOF DESIGN IN CONTEMPORARY BUILDINGS:

2.5.1. Slope: recommended angle of slope is 11 – 18 degrees.

In case of tiles or slate roofs, the angle shall be as per the manufacturers' specifications. (See fig.2.5.c.)

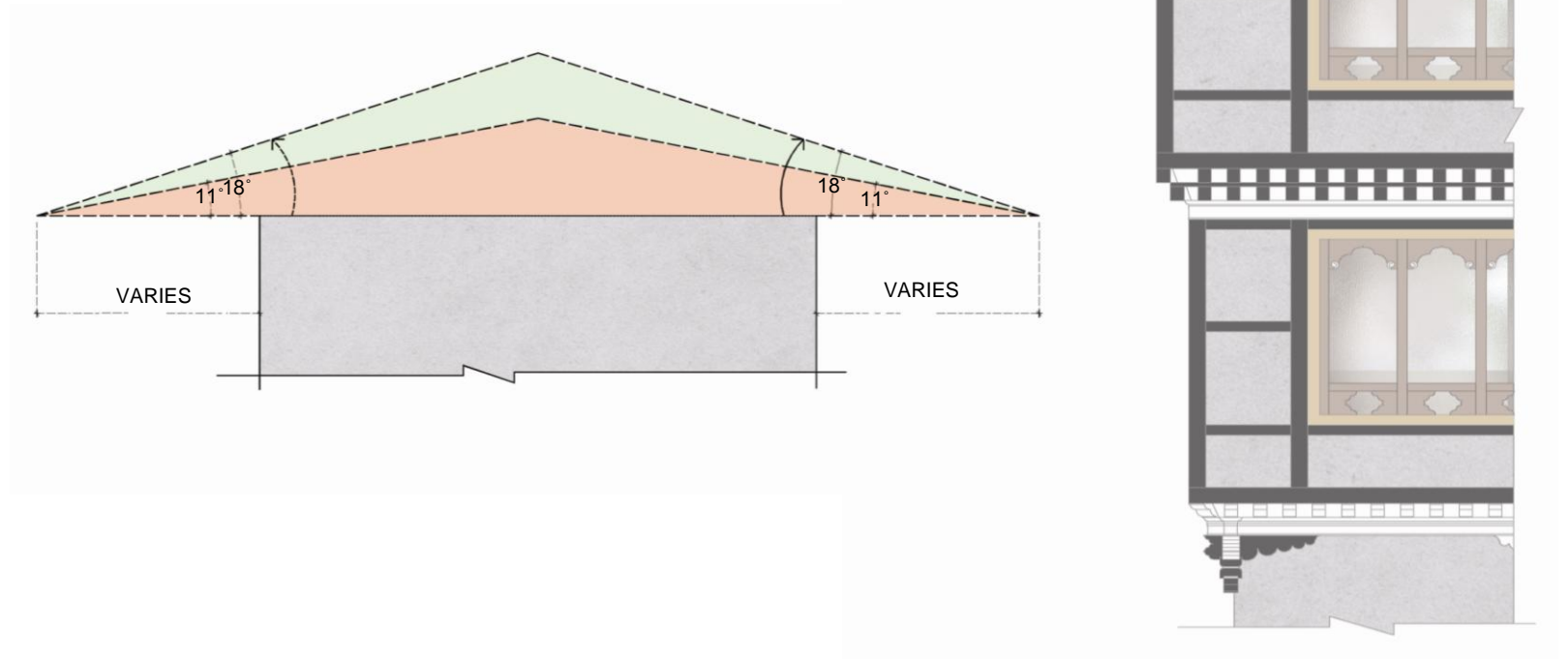
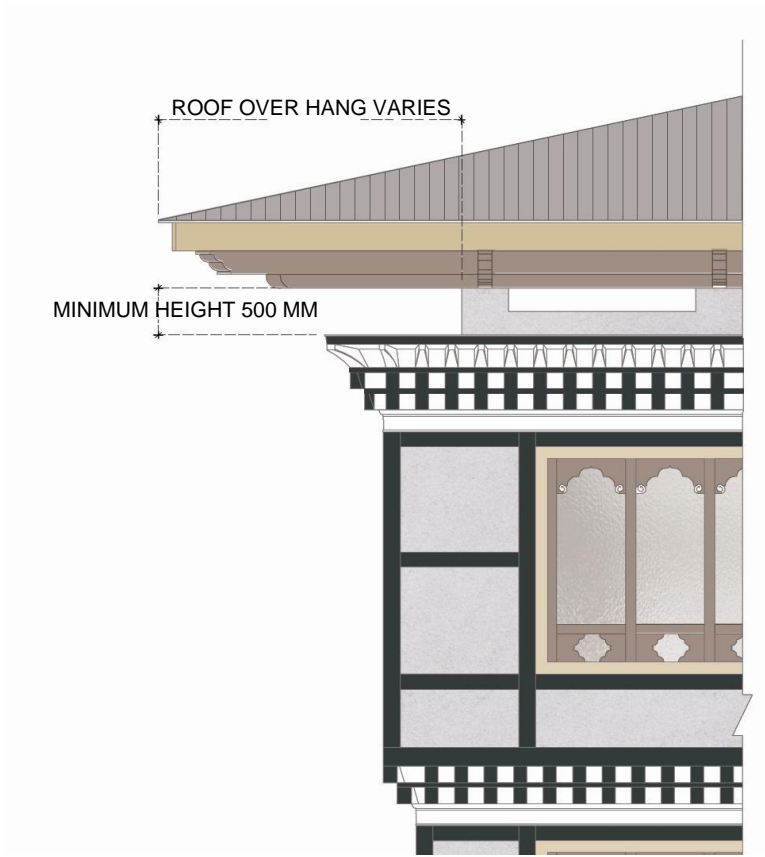

Fig.2.5.c. ROOF SLOPE ANGLE
(Drawing: Sunny Drukla)

2.5.2. A minimum space of 500mm is recommended between the Phakhep and bottom of eaves board for the main roof of buildings with two or more storeys. (See fig.2.5.d)

2.5.3. If roof elements Dhingri and Shathung are used, the space between the Dhingri and Phakhep shall be minimum 500mm for the main roof. (See fig. 2.5.d)



The space between Dhingri and Phakhep

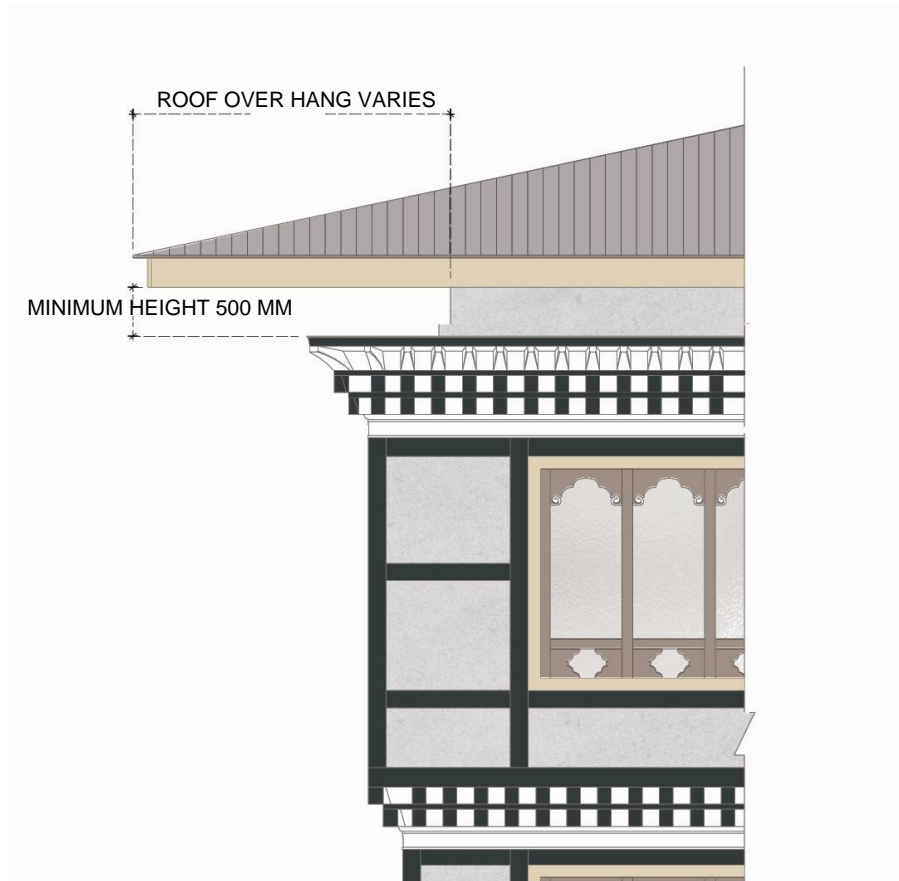

The space between eaves board and Phakhep

Fig.2.5.d. THE SPACE RECOMMENDED BETWEEN THE ROOF AND PHAKHEP FOR BUILDINGS WITH TWO OR MORE STOREYS
(Drawing: Sunny Drukla)

- 2.5.4.** A minimum space of 300mm is recommended between the Phakhep and bottom of eaves board for the main roof for single storey buildings. (See fig.2.5.e)



Fig.2.5.e. THE SPACE RECOMMENDED BETWEEN THE ROOF AND PHAKHEP FOR SINGLE STORIED BUILDING.

(Drawing: Sunny Drukla)

2.5.5. The Architect of record to propose overhang in proportion to the number of floors and as per the allowable setbacks.

The overhang dimensions recommended are (see Fig.2.5.f.):

- a) Minimum 1200 mm from wall for single storey buildings.
- b) Minimum of 1500mm from face of the Rabsel wall for two storey buildings.
- c) Minimum of 1800 mm from face of topmost Rabsel wall for buildings more than 2 storeys.

2.5.6. The width and length of Jamthok or Lungo roofs shall be minimum 1/3 of the main roof.

2.5.7. The Jamthok roof may or may not be adorned with cornices. However in Drangim roof, cornices are not recommended.

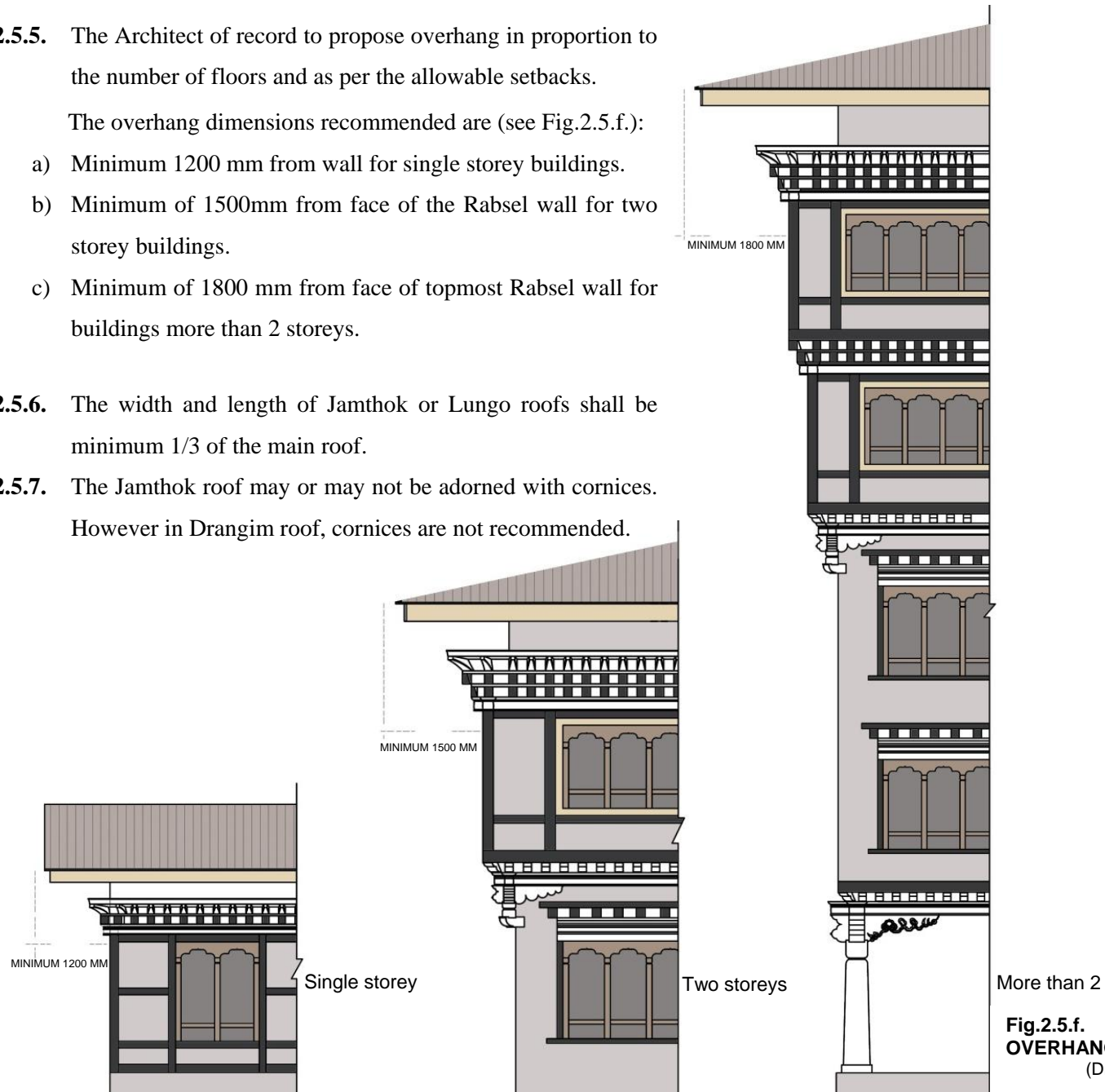

Fig.2.5.f. THE ROOF OVERHANG DIMENSION
(Drawing: Pashupati)

2.6 OTHER ELEMENTS AND ISSUES

2.6.1. Keymar: The use and interpretation of the Keymar as a decorative element (without religious connotations) to be left to the designer subject to approval.

2.6.2. Structural Glazing / Curtain Wall:

- a) Only up to an area of 30% of each building facade is recommended.
- b) Maximum width of each of the glazed area shall be 3m only.
- c) If recessed behind a facade with Kachens in ground floor areas of commercial buildings, area and width limitations are not applicable.
- d) Use of Reflective glass for structural glazing/curtain wall is not recommended.
- e) Tinted glass if proposed shall be subject to approval.
- f) Building proposals with glazing not conforming to above or those with different or special type of design shall require review and approval of the competent authority/committee made up of senior experienced Bhutanese architects and relevant professional experts.

2.6.3. Architect of record to furbish details and dimensions of traditional elements affecting the building façade.

ARCHITECTURAL THOBTHANG GUIDELINE FOR INDUSTRIAL AND OTHER BUILDING

This group of buildings will consist of Automobile Workshops, Garages, Bus stop/depots, Warehouses, Public toilets, Slaughter house, Gas stations and Sport Complexes.

Recommendations of minimum architectural elements:

1. For one storey structures:
 - Roofing: Gable or Hip
 - Openings: Payab; Payab Gedkar;
 - Kachen if incorporated must be with all necessary elements/Thobthang;

2. For Two or more storey structures:
 - Roofing: Gable, Hip, Jamthok, Lungo
 - Openings: Rabsel on top floor; Payab windows on lower floors; Gedkar windows can be used;
 - Kachen if incorporated must be with all necessary elements/Thobthang.

The above recommended architectural elements should be there on the facades facing road or community/public spaces. If the clients/designers desire more appropriate details (Rab & Ding) could be incorporated. However traditional architectural elements which has religious connotation such as Keymar, Gyeltshen and Sertog are discouraged.

PROFESSIONAL COMMITTEE FOR ASSESSMENT

The Bhutanese Architecture Guidelines is not meant to obstruct any creative or innovative new designs. Therefore, although the objective is to ensure the incorporation of traditional Bhutanese architecture as far as possible, new innovative and aesthetic designs are encouraged where possible. However, a Professional Committee is to be formed for approval of designs and buildings that may not conform to the Bhutanese Architecture Guidelines.

To ensure quality of assessment, the Committee should be made up of a minimum of three senior experienced Bhutanese Architects for a 3 to 5 year term. Ideally, the Committee may be a made of a mix of equally experienced architects both from the private sector and the Government where possible.

It is recommended that the Committee Architects are selected by the Ministry, Dzongkhag or Thromde based on their years of experience, good knowledge of local architecture and their noteworthy design projects in Bhutan. The Committee Architects must have a minimum of ten years of professional working experience in Bhutan as Architects and must be those who are respected both professionally and ethically by their peers.

The Committee shall review the presentation of the design by the Architect and analyze the quality of the proposed design to ensure that while new innovative designs are encouraged they ultimately add positive aesthetic value to the Bhutanese landscape and the built environment of Bhutan rather than being approved just for the sake of the new modern design.

BHUTANESE ARCHITECTURE DZONGKHA – ENGLISH TERMINOLOGY

Sl.No	Category	Term	Dzongkha Spelling				
1	GENERAL	Dzong	ཚོང་།	17		Gagona	གཤམ་གློ་ན།
2		Utse	དབུ་ཅེ།	18		Yokha	གཤམ་ལ།
3		Tshokhang	ཚོགས་ཁང་།	19		Choesham	མཚོན་བཤམ།
4		Kunrey	ཀུན་རུ།	20		Thabsang	ཐབ་ཚང་།
5		Gorekha	གོ་ར་ལ།	21		Yangthokha	ཡང་ཐོག་ལ།
6		Dochey	དོ་ཆལ།	22		Shambarna	གཤམ་བར་ནང་།
7		Zangdok Pelri	ཟངས་མདོག་དཔལ་རི།	23		Zam	ཟམ།
8		Lhakhang	ལྷ་ཁང་།	24		Zopen	བཟོ་དཔོན།
9		Patra	པ་ཏ།	25		Domang	མདོ་མངས།
10		Mani	མ་ཁི།	26		Gaytong	གཟུང་རྟོང་།
11		Goenpa	དགོན་པ།	27		Lochoe	ལོ་ཚོས།
12		Choeten	མཚོན་རྟེན།	28		Khung Dang Goepa	ཁུངས་དང་དགོས་པ།
13		Yue Chim	གཡུས་ཁྱིམ།	29		Thobthang	ཐོབ་ཐངས།
14		Taenthok	རྟེན་ཐོག།	30		Thigtshed	ཐིག་ཚང་།
15		Barthok	བར་ཐོག།	31		Khangsar	ཁང་གསལ།
16		Wothok	ལོག་ཐོག།	32		Rigsum Goempa	རིགས་གསུམ་མགོན་པོ།
				33		Keymar	ལྷེ་མར།

BHUTANESE ARCHITECTURE DZONGKHA – ENGLISH TERMINOLOGY

Sl.No	Category	Term	Dzongkha Spelling
34	ROOF	Chenkhep	ཇུན་ཁེབས།
35		Nyimkhep	ཉིན་ཁེབས།
36		Zuryab	ཟུར་གཡམ།
37		Jabzhi	ཇུབ་བཞི།
38		Jamthok	ཇུམ་ཐོག།
39		Lungo	ལུང་མོ།
40		Sertog	གསེར་རྟོག།
41		Gyeltshen	ཇུལ་མཚན།
42		Dharshing	དར་ཤིང་།
43		Reldri	རལ་མྱི།
44		Khorlo	འཁོར་ལོ།
45		Lhadhar	ལྷ་དར།

Sl.No		Term	Dzongkha Spelling
46		Chunjug	ཇུ་མཇུག།
47		Chusin	ཇུ་མིན།
48		Jachung	ཇུ་ཇུང་།
49		Gungchen	གུང་ཚེན།
50		Gungchung	གུང་ཇུང་།
51		Lungzey	ལུང་བཟེད།
52		Shari	ཤ་རིང་།
53		Shathung	ཤ་འབྱུང་།
54		Dhingri	ཐིང་རི།
55		Gha	ག།
56		Higchu	ཉིག་ཇུང་།
57		Zhupchung	གཞུབ་ཇུང་།

BHUTANESE ARCHITECTURE DZONGKHA – ENGLISH TERMINOLOGY

Sl.No	Category	Term	Dzongkha Spelling
58	RABSEL	Rabsel	རབ་གསལ།
59		Gomang	གོ་མང།
60		Gochha Thognyim	གོ་ཚེ་ཐོག་གཉིས་མ།
61		Lobur	ལོ་བུར།
62		Nimchog	ཉིན་ཚུང།
63		Geysargo	གེ་སར་གློ།
64		Parop	པ་རོ་པ།
65		Byelgo	བལ་གློ།
66		Phole Karchung	ཕོ་ལེ་བ་དཀར་ཚུང།
67		Gucha	གུ་ཅ།
68		Phakhep	ཕག་ལེ་བས།
69		Ngakhep	ངང་ལེ་བས།
70		Phana	ཕག་ལྷ།
71		Ngakey	ངང་གླེ།

Sl.No		Term	Dzongkha Spelling
72		Phuto Baw	ཕུ་བུ་བློ་ཕ།
73		Chamkhep	ཚུམ་ལེ་བས།
74		Cham	ཚུམ།
75		Boghkhep	བོག་ལེ་བས།
76		Bogh	བོག།
77		Boghdum	བོག་དུམ།
78		Ka	ཀ།
79		Trang	ཏང།
80		Choetse	ཚེ་བཙེན་གས།
81		Pem	པུ།
82		Norbu Bagum	ནོར་བུ་བ་གམ།
83		Norbu Horzhu	ནོར་བུ་འོ་ཉི་གམ།
84		Dhung	གཏུང།

BHUTANESE ARCHITECTURE DZONGKHA – ENGLISH TERMINOLOGY

Sl.No	Category	Term	Dzongkha Spelling
85	RABSEL	Zurchen	རུར་ཚེན།
86		Jang Dhung	ལྷན་གདུང།
87		Keyra Genthoe	མེད་རགས་རྗོན་ཐེམ།
88		Gongu	གོང་མགུ།
89		Yathoe	ཡ་ཐེམ།
90		Barthoe	བར་ཐེམ།
91		Zumbhur	རུར་རྒྱུར།
92		Lenbhur	ལེབ་རྒྱུར།
94		Jarbhur	རྒྱུར་རྒྱུར།
95		Shamig	ཤག་མིག།
97		Thrangcho	ཐང་རྒྱོད།
98		Budhen	རྒྱལ་གདན།

Sl.No		Term	Dzongkha Spelling
99		Tshechu Khanym	བཙམ་རུང་ལ་གཉིསམ།
100		Langna	ལྷན་རྣ།
101		Soma	སོམ།
102		Wotse	འོག་བཙམ།
103		Gye	གཡ།
104		Zhu	གཞུ།
105		Drey	ཐྲེ།
106		Gyetsa	གཡེ་ཙ།
107		Tazi	རྩ་གཟིགས།
108		Jadhang Tazi	བྱ་གདང་རྩ་གཟིགས།
109		Jana Tazi	རྒྱལ་གཟིགས།

BHUTANESE ARCHITECTURE DZONGKHA – ENGLISH TERMINOLOGY

Sl.No	Category	Term	Dzongkha Spelling
110	WINDOW	Payab	པར་གཡལ།
111		Gochu	གོ་ཅུ།
112		Horgo	ཉོར་གོ།
113		Gedkar	གུས་དཀར།
114		Lingo	ལིང་གོ།
115		Gyenthi-Godri	གོ་ཅན་གླེ་མ་གོ་ཅོ་ལྷོ་ག།
116		Zangshing	བཟང་ཤིང་།
117		Salen	ས་ལེན།
118		Zumchu	འཇུ་མ་ཅུང་།
119		Loshog	ལྷོ་ག་ཤོག།
120		Goshing	གོ་ཤིང་།
121		Zing	འཛིན།
122		Horzhu	ཉོར་གཟུ།
123		Kachung	ཀ་ཅུང་།
124		Jughshing	ཇུག་ཤིང་།
125		Tshigen	ཚོགས་ཇུག།
127		Enta	ཨེན་ཏ།
128		Diu	དིལ།

Sl.No	Category	Term	Dzongkha Spelling
129	DOOR	Go	གོ།
130		Jaka	འཇར་ཀ།
131		Genthoe	གོ་ཅན་གླེ་མ།
132		Chijhug	ཇི་ཇུག།

Sl.No	Category	Term	Dzongkha Spelling
133	COLUMN	Kachen	ཀ་ཚེན།
134		Kadhen	ཀ་གདན།
135		Threngwa	འཕྲེང་བ།
136		Chem	འཕྲེང་མ།
137		Raep	རལ་པ།
138		Kaw	ཀམ།
139		Gyechu	གོ་གཟུ།
140		Kami	ཀ་མི།